

# **Voluntary Water Efficiency Labelling Scheme on Showers for Bathing**

**December 2011 update**



48/F., Immigration Tower,  
7 Gloucester Road, Wanchai, Hong Kong  
Homepage: <http://www.wsd.gov.hk>

---

# CONTENTS

<b>Section</b>	<b>Title</b>	<b>Page</b>
1.	<b>Purpose</b>	2
2.	<b>Background</b>	2
3.	<b>Scope</b>	3
4.	<b>Definitions</b>	3
5.	<b>Testing Methodology and Standard</b>	4
6.	<b>Water Efficiency Grading</b>	5
7.	<b>Water Efficiency Label</b>	6
8.	<b>Testing Laboratories and Accreditation Bodies</b>	7
9.	<b>Application for Registration</b>	8
10.	<b>Legal Provisions</b>	12
11.	<b>Compliance Monitoring and Inspection</b>	12
12.	<b>Complaints and Appeals</b>	14
13.	<b>Maintenance of Scheme</b>	15

## **Annexes**

1	<b>Testing Guidelines for Showers for Bathing</b>
2	<b>Water Efficiency Label</b>
3	<b>Proforma Letter of Application</b>
4	<b>Information to be submitted to the Water Supplies Department</b>
5	<b>Flow Chart for Registration</b>

---

## 1. Purpose

This document is intended to give a detailed description of the Voluntary Water Efficiency Labelling Scheme (WELS) on Showers for Bathing.

## 2. Background

2.1 The voluntary WELS is one of the water conservation initiatives that the Government of the Hong Kong Special Administrative Region (HKSAR) has adopted. The WELS would cover common types of plumbing fixtures and water-consuming appliances. Products participating in the WELS will incorporate a water efficiency label that serves to tell consumers the water consumption level and efficiency rating. Consumers should then be able to take these factors into account in making their purchasing decision.

2.2 In overseas countries, the WELS is in different stages of development and implemented in several forms. In some countries, it is a compulsory requirement to provide water efficiency labels for certain kinds of plumbing fixtures and appliances before they can be put on sale in the market. For others, the WELS is implemented on a voluntary basis so as to allow a lead time for the market to transform towards more water efficient products. The implementation of WELS in Hong Kong adopts the latter approach and aims to achieve the following:

- (a) To provide consumers with information on the levels of water consumption and efficiency ratings of plumbing fixtures and water-consuming appliances;
- (b) To facilitate consumers to select water efficient plumbing fixtures and water-consuming appliances;
- (c) To promote public awareness on water conservation and efficiency issues; and
- (d) To achieve actual water savings.

2.3 The voluntary WELS in Hong Kong will be implemented in phases for different groups of plumbing fixtures and water-consuming appliances. The first group of products for implementation of the WELS is showers for bathing (hereinafter referred to as showers).

---

### 3. Scope

- 3.1 The Scheme will apply to the manufacturers, importers, or other related parties participating in the Scheme.
- 3.2 The Scheme **commenced** from **10 September 2009**. The revision of the Scheme has been implemented from **1 January 2012** and will expire on **31 December 2015** when re-registration is **not** necessary.
- 3.3 The Scheme only covers new showers imported to or manufactured in Hong Kong but does not cover second-hand products, products already in existing use, under trans-shipment or manufactured for export, etc.
- 3.4 The Scheme is operated as a ‘Grading Type’ labelling system. Under this Scheme, participating showers will be rated to different grades according to their nominal flow rates provided that they have met the performance requirements specified in the Scheme.
- 3.5 The provisions of this Scheme shall apply to the showers listed below:
- (a) showerheads installed to fixed arms/concealed pipes in the wall or ceiling;
  - (b) showerheads installed to pivotal arms; and
  - (c) hand-held showers.

### 4. Definitions

Unless otherwise specified, the following definitions shall apply throughout this document:

*Department* means the Water Supplies Department, the Government of HKSAR.

*shower* means a showerhead through which water is intended to flow to form a spray for bathing purposes, which may include a fixed or pivot arm, a flexible hose (with or without a flow controller), tap top assemblies, or other components.

---

<i>Director</i>	means the Director of the Water Supplies Department, the Government of HKSAR.
<i>Government</i>	means the Government of HKSAR.
<i>ISO</i>	means the International Organization for Standardization.
<i>IEC</i>	means the International Electrotechnical Commission.
<i>Inspecting Officer</i>	means the officer authorized by the Director to carry out the inspection as described in Section 11 of this document.
<i>Label</i>	means the water efficiency label (both full version and simplified version) as described in Section 7 of this document.
<i>participant</i>	means a manufacturer, an importer or other related party of the shower registered in the Scheme.
<i>recognized laboratory</i>	means a laboratory that complies with the requirements as stated in Section 8 of this document and is acceptable to the Department for carrying out tests (including re-tests) and issuing test reports on showers for bathing.
<i>Scheme</i>	means Hong Kong's Voluntary Water Efficiency Labelling Scheme on Showers for Bathing.

## **5. Testing Methodology and Standard**

### **General**

- 5.1 The testing methodology is described in Annex 1 with reference to the testing conditions and requirements specified in the Australian/New Zealand Standard No. AS/NZS 3662:2005 – Performance of Showers for Bathing with Amendment No. 1.

### **Flow Rate Test**

- 5.2 The nominal flow rates of the showers shall be determined in accordance with Annex 1. The water efficiencies of the showers will be rated to different grades according to the nominal flow rate test results subject to the compliance with other performance requirements mentioned in Section 5.3 below.

---

## Other Performance Requirements

- 5.3 The showers shall also be tested in accordance with Annex 1 for conformity with the performance requirements as shown in Table 1.

Table 1: Performance Requirements for Showers

Performance Property	Performance Requirements
Mean spray spread angle	The mean spray spread angle shall be between 0° and 8°.
Temperature drop	The temperature drop shall not exceed 3°C.
Endurance of the flow controller (if incorporated in a shower or being a component of a shower)	The flow rate which is re-measured after the endurance test of the flow controller shall be within $\pm 1$ litre/min of the nominal flow rate, as determined in the flow rate test.



## Quality Requirement

- 5.4 The showers shall be manufactured under a design (if applicable) and production system operating according to a recognized international quality system (such as ISO 9001).

## 6. Water Efficiency Grading

- 6.1 The water efficiencies of the showers are rated to different grades according to their nominal flow rates as shown in Table 2. Grade 1 is the most water efficient whereas Grade 4 is the least water efficient.

Table 2: Conversion of Nominal Flow Rates to Water Efficiency Grades

Nominal Flow Rate : $f$ (litres/minute)	Water Efficiency Grade	Symbolic Presentation on the Water Efficiency Label
$f \leq 9.0$	Grade 1	1 water droplet 
$9.0 < f \leq 12.0$	Grade 2	2 water droplets 
$12.0 < f \leq 16.0$	Grade 3	3 water droplets 

<b>Nominal Flow Rate : <i>f</i> (litres/minute)</b>	<b>Water Efficiency Grade</b>	<b>Symbolic Presentation on the Water Efficiency Label</b>
$f > 16.0$	Grade 4	4 water droplets 

- 6.2 If the shower cannot fulfil the performance requirements specified in Section 5.3 above, application for registration under the Scheme will not be accepted.

## 7. Water Efficiency Label

### Label Versions and Location

- 7.1 The Label should be self-adhesive **or pre-printed onto the packing**. There are two versions of the Label - full and simplified versions. It is a compulsory requirement for the participant to affix the full version Label to his/her registered shower or its packing at a prominent location. The participant should also ensure that the registered shower shall be displayed for sale with the full version Label. The simplified version Label is designed to facilitate the participant to affix it to the shower in case the full version Label is too large to do so. However, the affixation of the simplified version Label to the shower is optional.

### Colour Scheme and Dimensions

- 7.2 The Label should be printed on white-coloured self-adhesive sheet material and should have dimensions as shown in Annex 2. It should be printed in English and in Chinese. The soft copy of the Label can be obtained from the Department.

### Paper Quality

- 7.3 The paper used for the Label should be durable and possess good wear and tear characteristics. It should stick tightly on the shower or its packing.

### Information on the Label

- 7.4 The information that appears on the Label shall accord with the Label format as indicated in Annex 2 and shall tally with the information listed on the registration certificate issued by the Department.

---

## 8. Testing Laboratories and Accreditation Bodies

- 8.1 The testing is to be carried out either by an independent testing laboratory or by the manufacturers or the importers or other related parties themselves at their own testing laboratories. The Department will accept the results and certificates issued by the testing laboratories which fulfil one of the criteria as specified in Sections 8.2, 8.3 or 8.4.
- 8.2 The laboratory is accredited by the Hong Kong Accreditation Service (HKAS) for carrying out the tests stipulated in this Scheme under the Hong Kong Laboratory Accreditation Scheme (HOKLAS) or a scheme with which the HKAS has concluded a mutual recognition agreement<sup>#</sup>; and the results are issued in a test report or certificate bearing the accreditation mark.
- 8.3 An in-house laboratory fulfilling the criteria listed below:-
- Self-declaration by the manufacturer or importer or other related parties that the operations of their in-house laboratory follow the requirements of ISO/IEC 17025; **and**
  - The manufacturer is currently operating according to a recognized international quality system (such as ISO 9001); **and**
  - The manufacturer's or importer's or other related parties' in-house laboratory has been successful in carrying out tests on showers and where these tests have been evaluated and certified by internationally recognised third party certification organisations.

---

<sup>#</sup> HKAS has concluded mutual recognition arrangements with **seventy-six** overseas accreditation bodies for testing laboratory accreditation, namely, **UKAS** of the United Kingdom, **NATA** of Australia, **A2LA**, **ACLASS**, **ASCLD/LAB**, **NVLAP**, **L-A-B**, **PJLA**, **IAS**, **AIHA-LAP, LLC** and **FQS** of the United States, **IANZ** of New Zealand, **RvA** of Netherlands, **SAC** of Singapore, **BMWVJ** of Austria, **BELAC** of Belgium, **DANAK** of Denmark, **FINAS** of Finland, **COFRAC** of France, **INAB** of Ireland, **NA** of Norway, **ENAC** of Spain, **SWEDAC** of Sweden, **SAS** of Switzerland, **CNAS** of People's Republic of China, **TAF** of the Chinese Taipei, **CAI** of Czech Republic, **IAJapan**, **JAB** and **VLAC** of Japan, **KOLAS** of Korea, **SANAS** of South Africa, **SCC** and **CALA** of Canada, **NABL** of India, **BoA** of Viet Nam, **LA** of Lithuania, **SNAS** of Slovakia, **KAN** of Indonesia, **ISRAC** of Israel, **DSM** of Malaysia; **NSC-ONAC**, **OAA** of Argentina, **ONARC** of Cuba, **BAS** of Bulgaria, **INN** of Chile, **HAA** of Croatia, **EGAC** of Egypt, **DAKKS** of Germany, **NAT** of Hungary, **Accredia** of Italy, **NCA** of Kazakhstan, **OLAS** of Luxembourg, **PNAC** of Pakistan, **PNGLAS** of Papua New Guinea, **AAC Analitica** of Russian Federation, **SLAB** of Sri Lanka, **DMSc** and **DSS** of Thailand, **DAC** of United Arab Emirates, **OUA** of Uruguay, **EAK** of Estonia, **ESYD** of Greece, **LATAK** of Latvia, **PCA** of Poland, **SA** of Slovenia, **TUNAC** of Tunisia, **TURKAK** of Turkey, **NAB-MALTA** of Malta, **ema** of Mexico, **ECA** of Costa Rica, **OGA** of Guatemala, **RENAR** of Romania, **IPAC** of Portugal, **PAO** of the Philippines, etc. The list of mutual recognition arrangement partners may change from time to time and the up-to-date list is available from the HKAS website of <http://www.itc.gov.hk/en/quality/hkas/hoklas/agreement.htm>. Partners of these arrangements recognise the accreditations granted by one another as equivalent.



- 
- 8.4 A laboratory which achieves HOKLAS accreditation (or is accredited by a scheme with which HKAS has concluded a mutual recognition agreement) for laboratory testing of plumbing fixtures and water-consuming appliances other than the tests stipulated in the Scheme, and the laboratory can demonstrate capability of carrying out tests on showers in accordance with Annex 1.

## **9. Application for Registration**

### **Application Procedures**

- 9.1 All manufacturers, importers and other related parties in the shower business are welcome and encouraged to participate in the Scheme. For some known manufacturers and importers, invitation letters will be issued to them. However, any manufacturers, importers and other related parties in the shower business may submit applications for registration no matter whether they are invited or not.
- 9.2 The application for registration can be submitted by means of an application letter through post, facsimile or electronic mail to the Water Supplies Department:

Address: 47/F, Immigration Tower, 7 Gloucester Road, Wanchai, Hong  
Kong

Fax number: 2824 0578

Email: [wsdinfo@wsd.gov.hk](mailto:wsdinfo@wsd.gov.hk)

A proforma letter of application is attached in Annex 3. In order to ensure effective implementation of the Scheme, the participant must be committed to full compliance with the obligations set out in the Scheme. The proforma letter of application in Annex 3 details the obligations. The proforma application letter is also available at the Water Supplies Department's website (<http://www.wsd.gov.hk/en/wels/index.html>) for downloading. The application submission can be made in either English or Chinese.

---

## Information/Documents to be Submitted for Application

9.3 The information/documents to be submitted with the application are listed as follows:

- (a) Information of the company, i.e. name, address, telephone number, fax number, email address, website address, contact person, and sale distribution network (names and addresses of the distributor(s), etc.);
- (b) Information of the shower being applied for registration in the Scheme, i.e. brand name, model no. and/or name, catalogue (if available), country/region of origin and two photos clearly showing the front and side views of the shower;
- (c) Parties which will be responsible for making and affixing the Label;
- (d) Proposed commencement date to affix the Label to shower (Year \_\_\_\_\_, Month \_\_\_\_\_);
- (e) Documentary proof that the design (if any) and production system for the shower is operating according to a recognized international quality system (such as ISO 9001). The submission of product drawings extracted from the product manual or design manual, and international quality system certificate on the manufacturer can be considered as documentary proof of recognition quality system. Failure to the renewal of recognized international quality system may render the model registration null and void;
- (f) Detailed test report in accordance with the reporting requirements specified in Annex 1. The test report shall be issued by a recognized laboratory complying with the requirements in Section 8. The required information requested in Sections A5, B5, C4 and D4 of Annex 1 of the scheme document have to be provided in a single section of the test report; and
- (g) Statement on whether the testing laboratory has satisfied the requirement of Section 8.2, 8.3 or 8.4.

The above information is also listed in Annex 4. Upon the request of the Department, a reference sample of each shower to be participated in the Scheme shall be submitted by the participant at his/her own cost.

9.4 Company's chop should be stamped on all the documents provided. All photocopy test reports submitted to the Department shall be certified as true copy. Upon the request of the Department, the participant is required to provide the original copy of the test reports.

---

### **Acceptance/Rejection of Application**

- 9.5 On receipt of the application, the Department will verify whether the shower meets the performance requirements based on the submitted data and will rate the shower with a water efficiency grade according to the shower's nominal flow rate.
- 9.6 If the application is accepted, the participant will be notified of the result within 17 working days upon the receipt of all necessary information requested. A registration certificate listing the information to be displayed on the Label will be issued to the participant by the Department. The participant will then be allowed to affix the Label to the 'registered' shower or its packing. The participant should ensure that the Label is correctly printed and affixed to the shower or its packing in accordance with Section 7.
- 9.7 If the application is rejected, a notification letter will also be given to the applicant within 17 working days upon receipt of all necessary information requested.
- 9.8 The flow chart for registration is shown in Annex 5.

### **Participant's Obligations**

- 9.9 The participant is obliged to:
- (a) submit application, the information required in Section 9.3 and the test results which follow the format set out in Sections I and II of Annex 1;
  - (b) at his/her own costs, produce the Label and affix the full version Label either to the shower or its packing at a prominent location in accordance with Section 7;
  - (c) ensure that the registered shower shall be displayed for sale with the full version Label;
  - (d) fully inform other related parties (such as sales agents, retailers, etc.) in the participant's sale distribution network once the shower is registered under this Scheme and notify them that the Department may request to enter their premises to carry out the random/ad-hoc inspections in Section 11;
  - (e) allow random/ad-hoc inspection to be conducted by Inspecting Officers authorized by the Director on the registered shower at his/her premises;
  - (f) allow the tested flow rates and performance data of the registered

---

shower to be uploaded to the Department's website for public information;

- (g) conduct re-test(s) at his/her own costs at a recognized laboratory if non-compliance is found on the registered shower. The result of re-test(s) shall reach the Department within the time specified by the Department;
- (h) notify the Department by means of a notification letter (in either English or Chinese and the company's chop should be stamped on all submitted documents) through post, facsimile or electronic mail of any changes of the company information (e.g. company name). The notification should be made not less than 14 working days before the change. Failure to comply may render the model registration null and void. Changes of shower information (e.g. brand name, model no.) will be considered as major changes that require new applications for registration in the Scheme; and
- (i) remove within three months all Labels from the shower and its packing if it has been de-registered.

9.10 The details of showers registered under this Scheme will be kept in a register maintained by the Department. The registration records will be regularly uploaded to the Department's website for public information.

### **Termination**

9.11 Under circumstances of poor performance such as:

- (a) the participant failing to fulfil the obligations set out in the Scheme; or
- (b) the shower failing to perform in accordance with rated water efficiency grade and/or the performance requirements of the Scheme and the participant not being able to rectify the non-compliance within the time frame specified by the Department; or
- (c) where the Director is of the opinion that registration of a shower is contrary to the public interest,

the Department may de-register a shower from the Scheme with immediate effect by giving the participant notice in writing. Once a shower is de-registered, it is not allowed to affix a Label to it. The participant shall remove all Labels from the de-registered shower and its packing within three months from the notice.

- 
- 9.12 Participant who decides to discontinue participating in the Scheme or to withdraw any registered shower from the Scheme shall give at least three months' advance notice to the Department.

## **10. Legal Provisions**

- 10.1 Without prejudice to any remedy a purchaser may have against the party under the Laws of Hong Kong, a culpable party may be subject to the following sanctions.
- 10.2 This Scheme is a voluntary scheme. However, a participant who abuses the Scheme by giving false information on the Label may constitute an offence under the Trade Descriptions Ordinance, Cap 362.
- 10.3 Unauthorized use of the Label may constitute an offence under the Copyright Ordinance, Cap. 528.

## **11. Compliance Monitoring and Inspection**

### **Purpose**

- 11.1 To uphold credibility of the Scheme and to maintain continuous confidence of the consumers, compliance check on the Labels on those showers registered in the Scheme is necessary. In addition, to avoid the unsatisfactory situation that unauthorized Labels are used on non-registered showers, the Department may also carry out suitable form of inspection on those showers which have not been registered under the Scheme.

### **Scope**

- 11.2 The scope of inspection includes, but not limited to, sample checking and testing for the following items:
- (a) whether the Label is affixed to registered showers as required in Section 7;
  - (b) whether the Label being displayed is of correct format in accordance with Section 7;
  - (c) whether the water efficiency grade rated by the Department based on the data submitted by the participant is in line with the grade rated from

- 
- the results of random testing conducted by the Department;
- (d) whether the data shown on the Label tally with the information listed on the registration certificate; and
  - (e) whether unregistered showers display unauthorized Labels.
- 11.3 The participants will be requested to take immediate remedial action and report the follow-up action taken if non-compliance is found on their registered showers such as incorrect information shown on the Label.
- 11.4 The Department will periodically appoint a recognized laboratory to conduct random testing on the registered showers in accordance with the requirements specified in Sections I and II of Annex 1. For a registered shower which is found to fall within either one of the following cases, the Department may request the participant to conduct separate test at his/her own cost on the registered showers, in accordance with the testing methodology as stated in Annex 1 in a recognized laboratory agreed by the Department.
- (a) The shower is found not meeting the performance requirements specified in Section 5.3;
  - (b) The shower is found not meeting the water efficiency grade rated based on the data previously submitted by the participant in the application; or
  - (c) The measured flow rate of the shower is found deviated from the registered flow rate by more/less than 20%.

The test should be carried out on at least three further samples of the shower. For case (a) above, the performance test results of the three showers should meet the requirements specified in Section 5.3. If the test results fail to meet such requirements, the Department may either require the participant to withdraw his/her registration or de-register the shower from the Scheme. For case (b) above, the water efficiency grading rated from the average nominal flow rate of the three shower samples should be the same as the grading on the Label. Otherwise, the Department will require the participant to take appropriate remedial action including re-registering in the Scheme by replacing a Label with correct grading and flow rate for the registered shower.

- 11.5 If non-compliance is confirmed and no remedial action is taken by the participant within the time prescribed by the Department, the Department may order it be de-registered from the Scheme. Once a shower is

---

de-registered, it is not allowed to affix a Label to it. The participant shall remove all Labels from the de-registered shower and its packing within three months from the notice. Failure to remove the Labels from the de-registered shower may contravene the relevant ordinances as mentioned in Section 10 above.

### **Inspecting Officers**

- 11.6 The Director will authorize Inspecting Officers to carry out shower compliance monitoring and inspection. The officers will carry proper identification cards which will be produced during their inspection. However, the officers will not inform the participants in advance of their inspection.
- 11.7 It is the obligation of the participants to allow the Inspecting Officers to gain access to their premises to carry out the inspection.

### **Mode of Inspection**

- 11.8 Inspections will be carried out on registered showers under the Scheme on a random basis. Based on the record of the registration, random inspection programmes will be developed. Inspection will also be conducted on the non-registered showers with unauthorized Labels.
- 11.9 In addition to the random inspections, the Inspecting Officers will carry out ad-hoc inspections in response to complaints. The items to be inspected in such a case will depend upon the nature of complaint and may include the items as stated in Section 11.2.
- 11.10 Inspections will normally be carried out at the retail outlets and shower showrooms. Where necessary, inspection will also be done at warehouses.
- 11.11 The inspection results will be properly recorded for future analysis as well as on evaluation of the effectiveness of the Scheme.

## **12. Complaints and Appeals**

- 12.1 The Department will be responsible for dealing with complaints from participants and other parties against matters related to the Scheme.

---

### **Complaint Handling Procedure**

- 12.2 The Department shall ensure that complaints are properly recorded and handled without undue delay.
- 12.3 The Department shall carry out investigation on complaints and reply to them within a reasonable time. For complaints that require site inspection and laboratory test, the complainant shall be notified through an interim reply.
- 12.4 The Department shall inform the complainant of the result or decision made on the complaint.

### **Appeal Procedure**

- 12.5 A participant may appeal against the decision or action taken by the Department in writing to the Director stating the reason for the appeal.
- 12.6 The Director may decide to suspend the decision or action taken by the Department from the day on which the appeal is made until such appeal is disposed of, withdrawn or abandoned unless such suspension would, in the opinion of the Director, be contrary to public interest.
- 12.7 The Director may, by notice to the appellant, require the appellant to attend meeting(s) with him or his representatives and provide documents and give evidence relevant to the appeal.
- 12.8 The Director shall notify the appellant of his decision and reason for it. The decision will be final.

## **13. Maintenance of Scheme**

- 13.1 To ensure that the Scheme can continue to operate effectively and efficiently, the Scheme will be maintained as follows:
- (a) Continuous updating of the lists of showers registered in the Scheme as follows:
- i) registered showers with details such as registration numbers in the Scheme, dates of registration, flow rate data, performance data, makes, models and other related information; and



- 
- ii) manufacturers, importers or other related parties of the registered showers with details such as addresses, telephone numbers, email addresses, etc.
  
  - (b) Periodic review of the testing methodologies, procedures for registration application and compliance monitoring etc.
  
  - (c) Continuous evaluation of the effectiveness of the Scheme and assessment of what changes are necessary.

## **Testing Guidelines for Showers for Bathing**

### **Condensed Testing Requirements with reference to the AS/NZS 3662:2005 Standard with Amendment No. 1**

- Note -

*This Annex is a guideline to facilitate the participant to grasp the context of testing requirements. It makes reference to the Appendices B, C, D and F of the captioned standard and focuses on the measurement of water flow rate and other related performance aspects. The participant should be able to obtain from the text a good appreciation of the testing requirements. On the other hand, the captioned standard is much more comprehensive and detailed and contains exact definitions. Owing to condensed size, there is no intention to replace the captioned standard by this Annex. In case of doubt, the captioned standard should be consulted.*

*Section I of this Annex describes the methodology for determination of Nominal Flow Rate for Showers. Other performance tests for showers are elaborated in Section II.*

*The Department would like to acknowledge the assistance of the SAI Global Limited, Australia for granting permission to reprint the content of the above-mentioned Appendices under Licence 0904-C015.*

## Section I – Methodology for Determination of Nominal Flow Rate for Showers

### A1. Scope

This section sets out the method for determining the nominal flow rate of a shower.

### A2. Principle

The shower to be tested is supported in a test rig as specified in the AS/NZS 3662:2005 Standard and water is passed through the shower at dynamic flow pressures of 50 kPa, 150 kPa, 250 kPa, 350 kPa and 500 kPa; when the flow rate has stabilized it is recorded at each of these pressures at ambient water temperature.

### A3. Apparatus

The following apparatus is required:

- (a) A water supply capable of delivering water at: -
  - (i) A flow rate of more than 20 l/min; and
  - (ii) A dynamic flow pressure of at least 500 kPa.
- (b) Test apparatus made from DN 15, Type B copper pipe or equivalent. The branch for flow pressure measurements shall be located at least 250 mm downstream of any valve or fitting. The shower connection shall be not more than 300 mm downstream of the branch for flow pressure measurements. A typical test arrangement is shown in Figure A1 below.

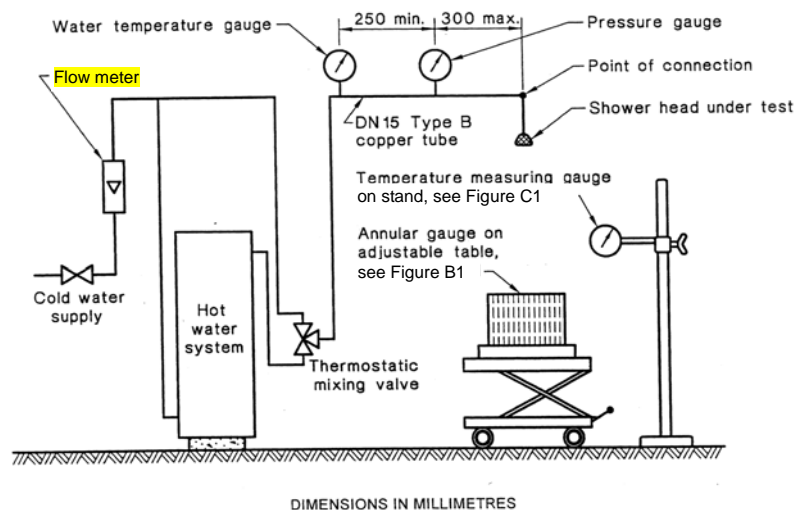

Figure A1 – Typical Test Arrangement

- (c) A pressure gauge having an accuracy of  $\pm 2\%$  of the true value.
- (d) A flow meter having an accuracy of  $\pm 2\%$  of the true value.

#### **A4. Procedure**

The procedure shall be as follows:

- (a) Where a shower is supplied with other components (e.g. an arm, shower hose, elbow with a flow controller) assemble the shower in accordance with the manufacturer's specified method of assembly.
- (b) For showers with adjustable spray settings, adjust the spray to the maximum flow setting.
- (c) Mount the shower in the test rig with the water supply connected to the intended inlet.
- (d) Condition the shower by allowing the water to flow and adjusting the control valve gradually until the dynamic flow pressure of 500 kPa is achieved. Maintain the flow until the flow and pressure remain stable for at least 1 minute.
- (e) Gradually adjust the control valve to turn off the flow of water.
- (f) Gradually turn on the flow of water until a stabilized flow at a dynamic flow pressure of 50 kPa is achieved.
- (g) Observe the flow meter and record the flow rate at that dynamic flow pressure.
- (h) Repeat steps (f) and (g) with the dynamic flow pressure increased to 150kPa, 250 kPa, 350 kPa and then to 500 kPa.
- (i) Gradually adjust the control valve to turn off the flow of water.
- (j) Repeat steps (f) and (i) to obtain a second reading of the flow rates at the range of pressures.
- (k) Calculate and record the average flow rates at each of the following dynamic pressures:
  - (i) 50 kPa
  - (ii) 150 kPa
  - (iii) 250 kPa
  - (iv) 350 kPa
  - (v) 500 kPa
- (l) Calculate the mean of the average flow rates obtained in Steps (k)(ii) to (k)(iv), and record this value as the nominal flow rate. Please note that although the shower is tested from 50 kPa to 500 kPa, the recording of the average flow

rate at the pressures of 50 kPa and 500 kPa is to facilitate consumers in making their shower selection.

**A5. Test Report**

The following shall be reported and attached:

- (a) Manufacturer, brand name, model name and model number (if these are applicable) of the shower.
- (b) Provide a table showing the average flow rates through the test sample, at the dynamic flow pressures of:

Dynamic flow pressure (kPa)	50	150	250	350	500
Average flow rate (litres/minute)					

Note: The average flow rate as determined in paragraph A4 (k)

- (c) The nominal flow rate in 1 decimal place (e.g. 8.2 litres/minute).  
Note: As determined in paragraph A4 (l).
- (d) Three photos clearly showing the front view of the shower spray holes, side view of the shower and the connection hole/flow controller of the shower.
- (e) Statement on the assembly of the shower for testing as required in paragraph A4(a), e.g. test conducted with other components such as flow controller.
- (f) Combine the test report sections as specified in Section II to form a complete test report.

**Section II – Methodology for other Performance Tests for Showers**

---

**Scope**

This section outlines the methodology for the following performance tests:-

- (a) Determination of mean spray spread angle;
- (b) Measurement of temperature drop; and
- (c) Endurance test for flow controllers used in showers (if incorporated in showers or being components of showers)

## B Determination of Mean Spray Spread Angle

### B1. Principle

The shower is supported in a test rig. Water is run through the shower, at a dynamic pressure of 250 kPa and ambient water temperature, into an annular gauge. The water collected in each section of the gauge is then measured and the mean spray spread angle is calculated

### B2. Apparatus

The following apparatus is required:-

- (a) A water supply capable of delivering water at:-
  - (i) A flow rate of more than 20 l/min; and
  - (ii) A dynamic flow pressure of at least 500 kPa.
- (b) An annular gauge as shown in Figure B1.
- (c) A flow meter to measure total flow to within  $\pm 2\%$  of the true value.
- (d) Measuring cylinders to measure, within  $\pm 5$  ml/l, the volume of water collected in each annular cylinder of the annular gauge.
- (e) A stopwatch with an accuracy of  $\pm 0.1$ s.
- (f) A tape measure.

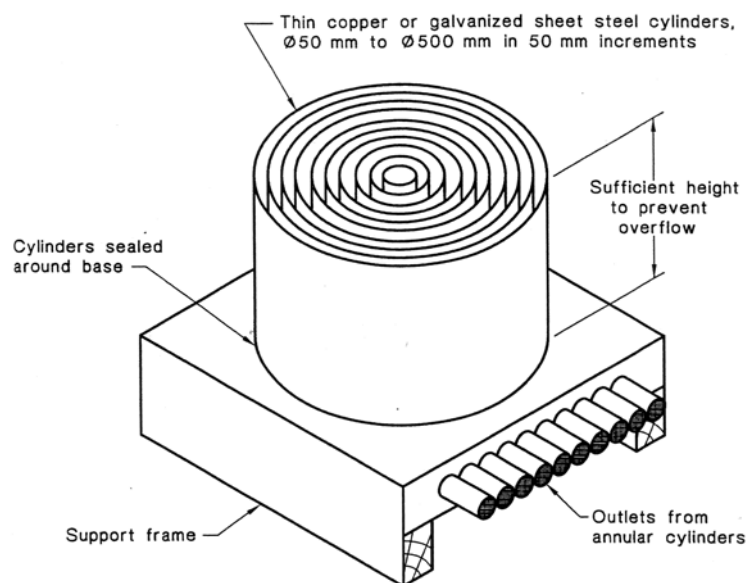

NOTE: Cylinders with wall thickness in excess of 1 mm should be bevelled inwards to relevant cylinder.

Figure B1 – Typical Annular Gauge

**B3. Procedure**

The procedure shall be as follows:

- (a) Where a shower is supplied with other components (e.g. an arm, shower hose, elbow with a flow controller) assemble the shower in accordance with the manufacturer's specified method of assembly.
- (b) For showers with adjustable spray settings, adjust the spray to the maximum flow setting.
- (c) Mount the shower in the test rig with the water supply connected to the intended inlet with the faceplate horizontal.
- (d) Place the annular gauge underneath the shower so that the centre-line of the faceplate and the centre cylinder are in vertical alignment and the top of the annular gauge is  $400 \pm 5$  mm from the faceplate.
- (e) Cover the top of the annular gauge and adjust the water supply to flow at a stabilized dynamic pressure of 250 kPa. Remove the cover and allow the water to flow through the shower and into the annular gauge for at least 60 seconds.
- (f) Record the total flow reading on the flow meter and the time to the nearest second, ensuring that the water supply is allowed to flow through the shower and into the annular gauge.
- (g) Collect, measure and record the volume of water in each annular cylinder. Determine the total flow collected by all annular cylinders.
- (h) If the total flow collected by all annular cylinders and the total flow recorded on the flow meter vary by more than  $\pm 5\%$ , repeat Steps (e) to (g).
- (i) If the total flow rate collected by all annular cylinders and the total flow recorded on the flow meter do not vary by more than  $\pm 5\%$ , determine the percentage of water collected in each of the annular cylinders.
- (j) Calculate the effective diameter of the shower as indicated in Paragraph B4.
- (k) Calculate the mean spray spread angle of the shower using the following equation:-

$$\text{Mean spray spread angle} = \tan^{-1} \left\{ \frac{\sum_1^N [X_N(2N-1)] - 4ED}{3200} \right\}$$

Where:-

$ED$  = effective diameter of showerhead, in millimetres (See Clause B4 to calculate this variable)

$X_N$  = Percentage of the total flow collected by the individual annular cylinders, as determined in Step (i) above

$N$  = Number of the annular cylinder, counting from the centre out, i.e.  
 = 1 (i.e. the 50 mm diameter cylinder)  
 = 2 (i.e. the 100 mm diameter cylinder)  
 = 3 (i.e. the 150 mm diameter cylinder)  
 = .....  
 = .....  
 = 10 (i.e. the 500 mm diameter cylinder)

as such,

$X_1$  = Percentage of the total flow collected by the 50 mm diameter cylinder

$X_2$  = Percentage of the total flow collected by the 100 mm diameter cylinder

**B4. Calculation of Effective Diameter**

**(a) Case 1 – Showerhead with a circular pattern of holes on a single diameter**

For a showerhead with a faceplate that has a circular pattern of holes along a single diameter pattern, calculate the effective diameter ( $ED$ ) using the following equation:

$$ED = D$$

Where

$D$  = projected diameter along which the holes lie (see Figure B2, Case 1)

**(b) Case 2 – Showerhead with a circular pattern of holes on several diameters**

For a showerhead with a faceplate that has a circular pattern of holes along several circular patterns of varying diameters, calculate the effective diameter



(ED) using the following equation:

$$ED = \frac{[(H_1 \times D_1) + (H_2 \times D_2) + (H_3 \times D_3) + (H_4 \times D_4) + (H_5 \times D_5) + (\dots)]}{H_1 + H_2 + H_3 + H_4 + H_5 + \dots}$$

Where

$D_1$  = Projected diameter along which the innermost holes lie

$D_2$  = Projected diameter along which the second innermost holes lie

$D_3$  = Projected diameter along which the third innermost holes lie etc.

and

$H_1$  = Number of holes that lie along the innermost projected diameter

$H_2$  = Number of holes that lie along the second innermost projected diameter

$H_3$  = Number of holes that lie along the third innermost projected diameter (see figure B2, Case 2)

**(c) Case 3 – Showerhead with holes on evenly spaced pattern**

For a showerhead with a faceplate that has an evenly spaced pattern of holes that can be approximated to a circular pattern, calculate the effective diameter (ED) using the following equation:

$$ED = \frac{D}{\sqrt{2}}$$

Where

$D$  = maximum distance between the outermost holes (see Figure B2, Case 3)

**(d) Case 4 – Showerhead with non-circular patterns of holes**

For a showerhead with a non-circular pattern of holes (see Figure B2, Case 4)

**Option 1**

Rectangular shaped spray patterns

$$ED = \sqrt{\left\{ \frac{(W \times B \times 4)}{\pi} \right\}}$$

Where

$B$  = breadth of the spray pattern

$W$  = width of the spray pattern

**Option 2**

Rectangular or other shaped spray patterns (circularizing parameters of spray pattern) use the equation in Case 2.

**B5. Test Report**

The following shall be reported and formed part of the test report specified in paragraph A5:

- (a) Total flow rate (l/min) for all the annular cylinders
- (b) Percentage of the total flow collected by each annular cylinder
- (c) The calculated mean spray spread angle

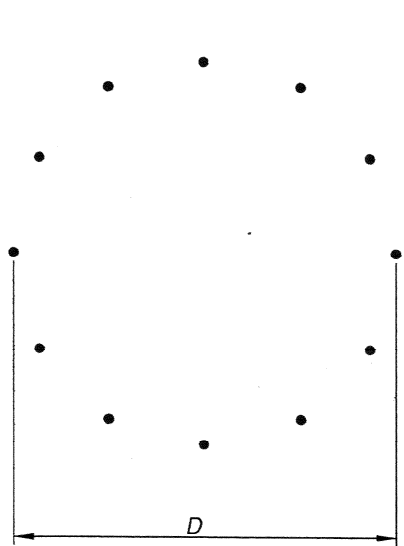

**Case 1**

Showerhead with a circular pattern of holes on single diameter

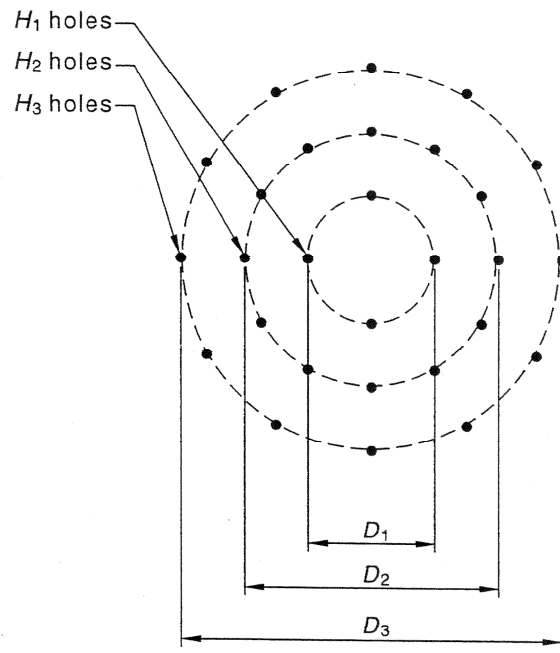

**Case 2**

Showerhead with a circular pattern of holes on several diameters

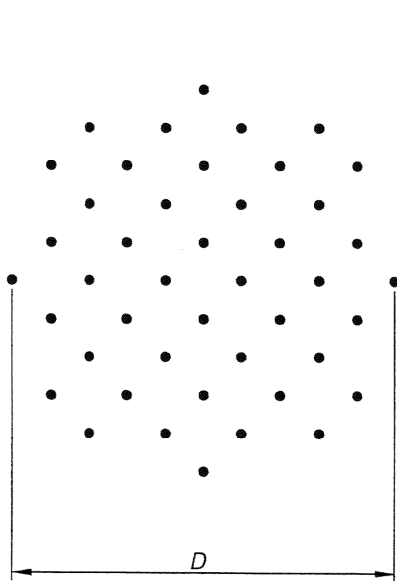

**Case 3**

Showerhead with a pattern of evenly spaced holes

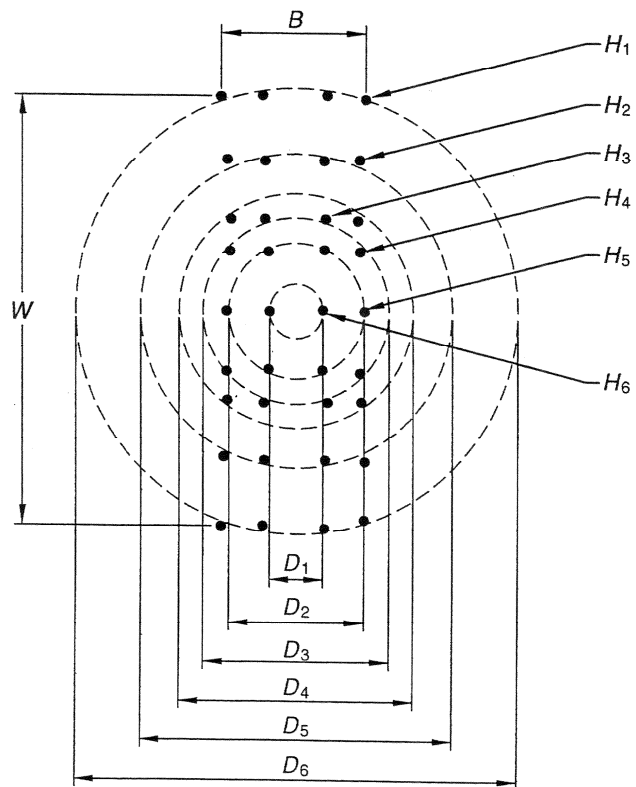

**Case 4**

Showerhead with a non-circular pattern of holes

Figure B2 – Various Shaped Showerheads for Calculating the Effective Diameter

**C Measurement of Temperature Drop****C1. Principle**

Heated water is passed through a shower at a dynamic pressure of 250 kPa. The temperature of the water flow is measured at 150 mm and at 750 mm below the faceplate and the temperature drop is determined.

**C2. Apparatus**

The following apparatus is required:-

- (a) A water supply capable of delivering heated water at:
  - (i) A temperature of  $20 \pm 3^{\circ}\text{C}$  above ambient;
  - (ii) Flow rate at of more than 20 l/min; and
  - (iii) A dynamic flow pressure of at least 250 kPa.
- (b) A temperature gauge as shown in Figure C1, having a differential temperature accuracy of  $\pm 0.5^{\circ}\text{C}$ .
- (c) A pressure gauge having an accuracy of  $\pm 2\%$  of the true value.
- (d) A flow meter to measure total flow to within  $\pm 2\%$  of the true value.
- (e) A tape measure.

**C3. Procedure**

The procedure shall be as follows:

- (a) Where a showerhead is supplied with other components (e.g. an arm, shower hose, elbow with a flow controller), assemble the shower in accordance with the manufacturer's specified method of assembly.
- (b) For showers with adjustable spray settings, adjust the spray to the maximum flow setting.
- (c) Mount the shower in the test ring with the water supply connected to the intended inlet with the faceplate horizontal and  $150 \pm 5$  mm vertically above the temperature gauge.
- (d) Measure ambient air temperature.
- (e) Adjust the water supply temperature to  $20 \pm 3^{\circ}\text{C}$  above ambient temperature.
- (f) Allow the water to flow and adjust the control valve gradually until the

## Annex 1

dynamic flow pressure of 250 kPa is achieved. Maintain the flow until the flow and pressure remain stable for at least 1 minute.

- (g) Allow the temperature on the gauge to stabilize and record the reading.
- (h) Lower the temperature gauge to a position  $750 \pm 5$  mm below the faceplate. Move the gauge in its horizontal plane to find the most advantageous location to maximize the temperature reading on the gauge. Allow the temperature on the gauge to stabilize and record the reading.
- (i) Raise the temperature gauge to its original position. Allow the temperature on the gauge to stabilize and record the reading.
- (j) If the temperature recorded in Steps (g) and (i) vary more than  $\pm 0.5^\circ\text{C}$ , repeat Steps (d) to (i).
- (k) If the temperature recorded in Steps (g) and (i) do not vary more than  $\pm 0.5^\circ\text{C}$ , record the reading in Step (i).
- (l) Calculate the difference in the temperatures measured in Steps (g) and (h) and record this as the temperature drop of the shower.

### C4. Test Report

The following shall be reported and formed part of the test report specified in paragraph A5:

- (a) Ambient air temperature
- (b) Supply heated water temperature
- (c) Water temperatures measured when the faceplate was 150 mm from the temperature gauge, as recorded in paragraph C3 (g).
- (d) Water temperature measured when the faceplate was 750 mm from the temperature gauge, as recorded in paragraph C3 (h).
- (e) Water temperature measured when the faceplate was returned to its initial position of 150 mm from the temperature gauge, as recorded in paragraph C3 (i).
- (f) Temperature drop, as recorded in paragraph C3 (l).

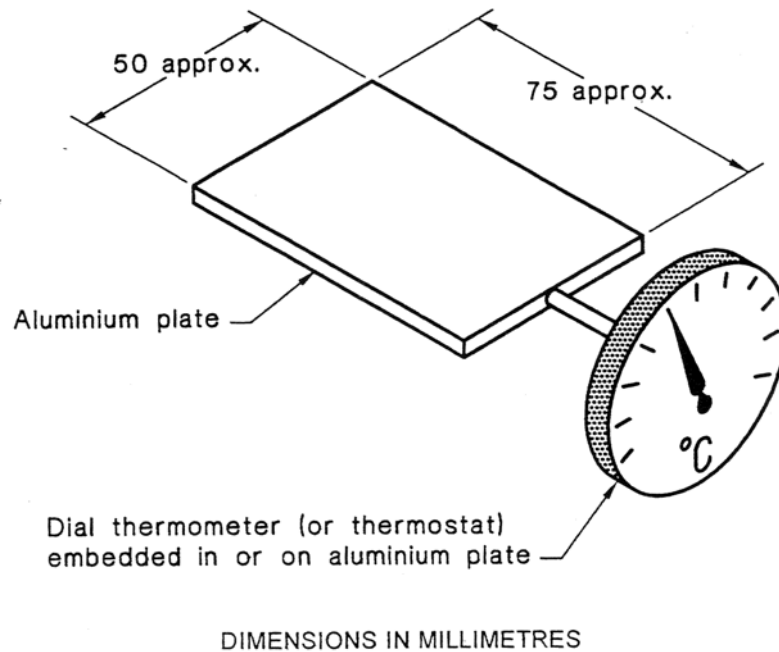

Figure C1 – Typical Temperature Measuring Gauge

**D** **Endurance Test for Flow Controllers used in Showers (if incorporated in showers or being components of showers)**

**D1. Principle**

The flow controller, mounted in the same housing (test sample) as used in the shower, is held in a test rig and connected to a temperature-controlled heated and cold water supply at a given pressure. A cyclic mechanism is used to open and close the valve providing water to the test sample. A device to monitor the system for inconsistencies and breakdown is integrated in the mechanism. On completion of the pressure cycles, the test sample is retested in accordance with Section I of this Annex.

**D2. Test Rig Apparatus**

A test rig fitted with a counter to count complete cycles, and capable of –

- (a) Operating the test sample through 10 000  $\pm 100$  cycles from 0 kPa to 350 kPa;
- (b) Delivering heated water at a temperature of 55  $\pm 3^\circ\text{C}$ ;
- (c) Delivering a flow rate of 20 l/min at 350 kPa;
- (d) Providing 12  $\pm 1$  cycles per min; and

- (e) Alternating ambient and heated water every 55 ±5 cycles.

**D3. Procedure**

The procedure shall be as follows:

- (a) Test the sample in accordance with Section I of this Annex to determine and record the initial nominal flow rate and average flow rates at 150 kPa, 250 kPa, and 350 kPa of the test sample.
- (b) Connect the test sample to the test rig.
- (c) Adjust the supply pressures with each water supply and check that the pressures and water temperatures are as specified.
- (d) Commence the opening and closing operation of the valves supplying water to the test sample.
- (e) Reset the cycle counter to zero.
- (f) Commence the cycles at 12 ±1 cycles per minute for 10 000 ±100 cycles between 0 kPa and 350 kPa and alternate ambient and heated water every 55 ±5 cycles.
- (g) At the completion of Step (f), retest the test sample in accordance with Section I of this Annex to determine and record the final nominal flow rate and average flow rates at 150 kPa, 250 kPa and 350 kPa of the test sample.
- (h) Calculate the difference between the nominal flow rates of the test sample determined in Step (a) and Step (g).

**D4. Test Report**

The following shall be reported and formed part of the test report specified in paragraph A5:

- (a) Manufacturer, model, size and type of the housing and flow controller
- (b) Number of cycles completed
- (c) Initial nominal flow rate and average flow rates of the test sample determined in paragraph D3 (a)
- (d) Final nominal flow rate and average flow rates of the test sample determined in paragraph D3 (g)
- (e) The difference between the nominal flow rates of the test sample determined in paragraph D3 (h)

# Water Efficiency Label

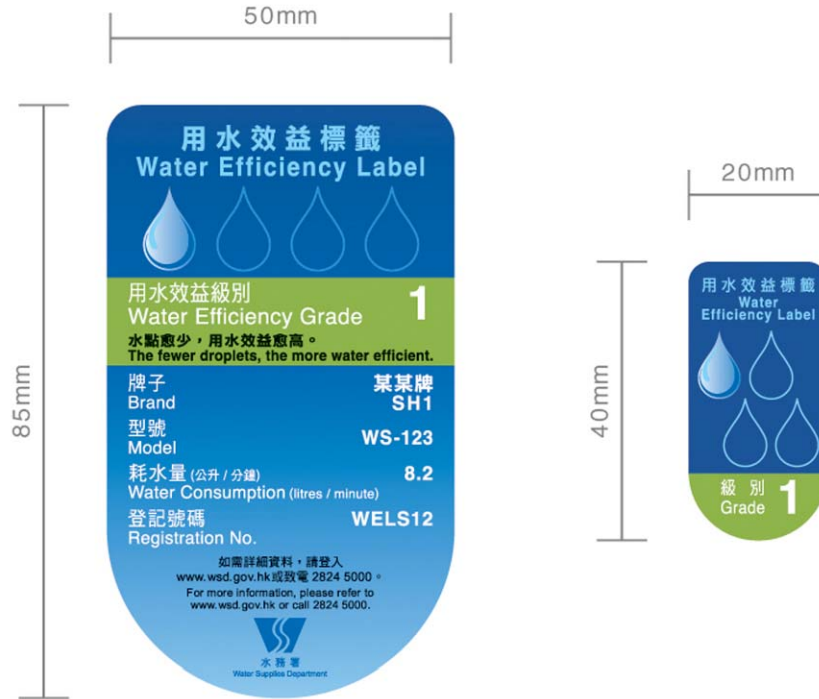



## Water Efficiency Label

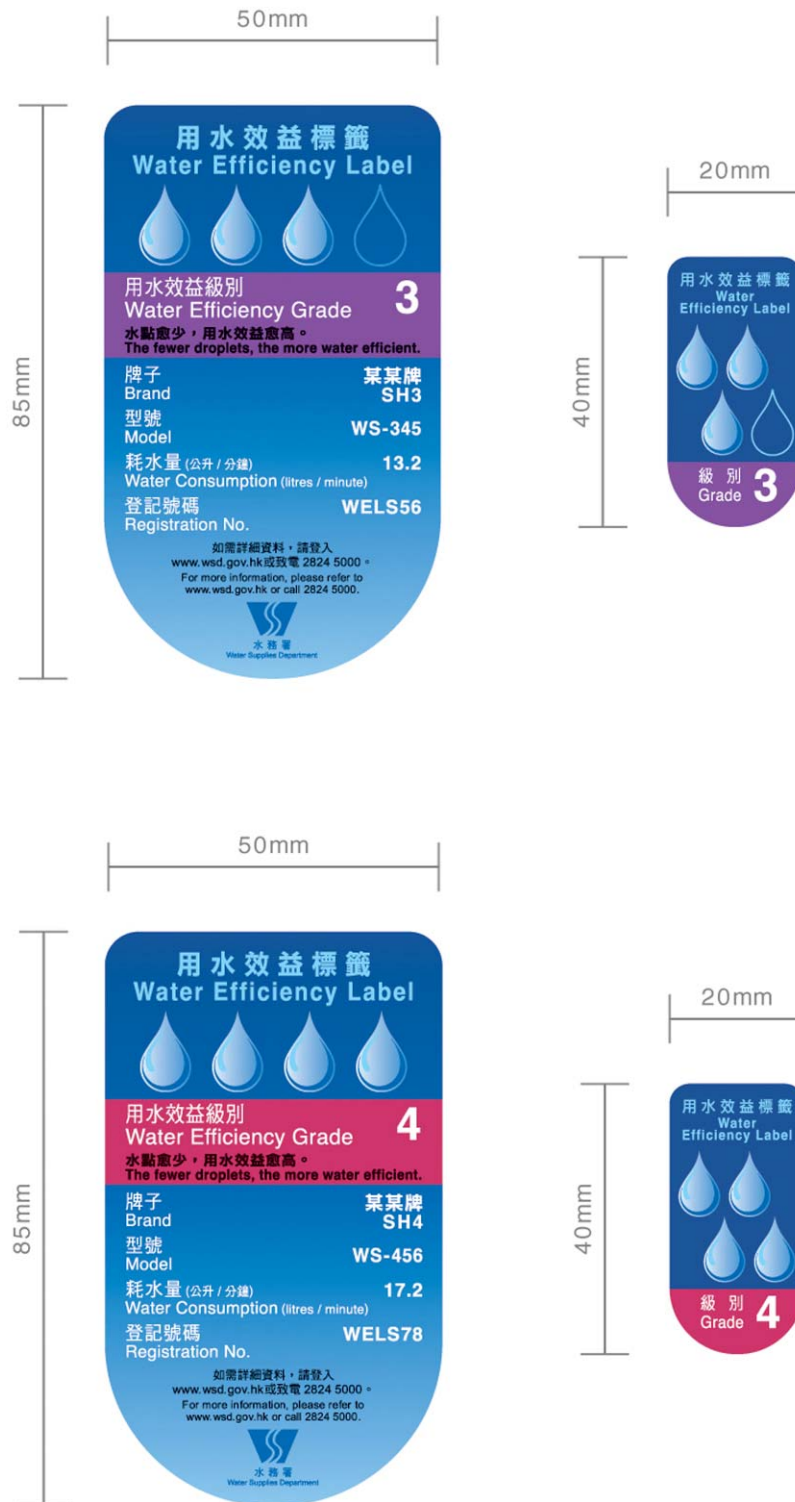

### Notes:

1. Dimensions of the full and simplified versions of the water efficiency label are 85mm x 50mm and 40mm x 20mm respectively.
2. The soft copy of the water efficiency label can be obtained from the Water Supplies Department.
3. The water consumption figure shown in the water efficiency label is the nominal flow rate of the shower as determined in accordance with the Scheme.

## **Proforma Letter of Application**

Our ref.

Tel.

Fax.

Date

Water Supplies Department  
47/F, Immigration Tower  
7 Gloucester Road, Wanchai  
Hong Kong

Dear Sir/Madam,

### **Application for Registration in the Voluntary Water Efficiency Labelling Scheme on Showers for Bathing**

Our company is the (manufacturer / importer / other related parties (please specify)\*) of \_\_\_\_\_ (brand name, model number and/or name of shower) in Hong Kong. We would like to apply for registration of the shower in the above Scheme.

We understand fully our obligations as stated in the document of “Voluntary Water Efficiency Labelling Scheme on Showers for Bathing” (Scheme Document) and will comply with all relevant requirements, in particular those specified below:

- (a) submit application, the information required in Section 9.3 of the Scheme Document and the test results which follow the format and procedures set out in Sections I and II of Annex 1 of the Scheme Document;
- (b) at our own costs, produce the water efficiency label and affix/print the full version water efficiency label either to the shower or its packing at a prominent location in accordance with Section 7 of the Scheme Document;
- (c) ensure that the registered shower shall be displayed for sale with the full version water efficiency label;
- (d) fully inform other related parties (such as sales agents, retailers, etc.) in our sale distribution network once the shower is registered under the above

### Annex 3

Scheme and notify them that the Water Supplies Department (WSD) may request to enter their premises to carry out random/ad-hoc inspections in Section 11 of the Scheme Document;

- (e) allow random/ad-hoc inspection to be conducted by Inspecting Officers authorized by the Director of Water Supplies on the registered shower at our premises;
- (f) allow the tested flow rates and performance data of the registered shower to be uploaded to WSD's website for public information;
- (g) conduct re-test(s) at our own costs at a recognized laboratory complying with the requirements in Section 8 of the Scheme Document if non-compliance is found on the registered shower. The result of re-test(s) shall reach WSD within the time specified by WSD;
- (h) inform WSD of any change in accordance with Section 9.9(h) of the Scheme Document; and
- (i) remove within three months all water efficiency labels from the shower and its packing if it has been de-registered.

The detailed information of the shower which we apply for registration is shown in the attached documents (see Annex 4 for the list of information to be submitted) for your processing.

Yours faithfully,

(Manufacturer/Importer/Agent's Name and Company Chop)

---

\* *delete as appropriate*

**Information to be Submitted**  
**to the Water Supplies Department**

1. Information of the company, i.e. name, address, telephone number, fax number, email address, website address, contact person, and sale distribution network (e.g. names and addresses of the distributor(s), etc.).
2. Information of the shower being applied for registration in the Scheme, i.e. brand name, model no. and/or name, catalogue (if available), country/region of origin and two photos clearly showing the front and side views of the shower.
3. Parties which will be responsible for making and affixing the water efficiency label (Label).
4. Proposed commencement date to affix the Label to shower (Year \_\_\_\_\_, Month \_\_\_\_\_).
5. Documentary proof that the design (if any) and production system for the shower is operating according to a recognized international quality system (such as ISO 9001).
6. Detailed test report in accordance with the reporting requirements specified in Annex 1 of the Scheme Document. The test report shall be issued by a recognized laboratory complying with the requirement in Section 8 of the Scheme Document. The required information requested in Sections A5, B5, C4 and D4 of Annex 1 of the Scheme Document have to be provided in a single section of the test report.
7. Statement on whether the testing laboratory has satisfied the requirement of Section 8.2, 8.3 or 8.4 of the Scheme Document.

*Note: Company's chop should be stamped on all the documents provided. All test reports submitted to the Water Supplies Department (WSD) should be certified as true copy. Upon the request of WSD, the participant is required to provide the original copy of the test reports for perusal.*

---

**Flow Chart for Registration**

