

TCO Certified Tablets 2.0



1 November 2012

Contents - TCO Certified Tablets

SUPPORT (ON THIS DOCUMENT AND TCO CERTIFICATION)	5
INTRODUCTION	6
A CRITERIA	7
A.1 GENERAL INFORMATION	7
A.1.1 TCO CERTIFIED DOCUMENT.....	8
A.2 VISUAL ERGONOMICS	9
A.2.1 IMAGE DETAIL CHARACTERISTICS	10
A.2.1.1 <i>Native display resolution requirement</i>	10
A.2.2 LUMINANCE CHARACTERISTICS	11
A.2.2.1 <i>Luminance level</i>	11
A.2.2.2 <i>Luminance uniformity</i>	12
A.2.2.3 <i>Luminance uniformity - angular-dependence</i>	13
A.2.3 LUMINANCE CONTRAST CHARACTERISTICS.....	14
A.2.3.1 <i>Luminance contrast – characters</i>	14
A.2.3.2 <i>Luminance contrast – angular dependence</i>	15
A.2.4 REFLECTION CHARACTERISTICS.....	16
A.2.4.1 <i>Front frame gloss</i>	16
A.2.5 SCREEN COLOUR CHARACTERISTICS	18
A.2.5.1 <i>Correlated colour temperature, CCT variation</i>	18
A.2.5.2 <i>Colour uniformity</i>	19
A.2.5.3 <i>RGB settings</i>	20
A.2.5.4 <i>Colour uniformity – angular dependence</i>	21
A.2.5.5 <i>Colour greyscale linearity</i>	22
A.4 EMISSIONS	23
A.4.3 ACOUSTIC NOISE	23
A.5 ELECTRICAL SAFETY	25
A.5.1 ELECTRICAL SAFETY	25
A.6 ENVIRONMENTAL REQUIREMENTS	26
A.6.1 PRODUCT DESCRIPTION.....	27
A.6.2 ORGANISATION	29
A.6.2.1 <i>Environmental management system certification</i>	29
A.6.3 CLIMATE.....	31
A.6.3.1 <i>Energy consumption</i>	31
A.6.4 ENVIRONMENTALLY HAZARDOUS SUBSTANCES.....	32
A.6.4.1 <i>Mercury (Hg) free product</i>	32
A.6.4.2 <i>Cadmium (Cd), lead (Pb) and hexavalent chromium (Cr6)</i>	33
A.6.4.3 <i>Halogenated substances</i>	34
A.6.4.4 <i>Non-halogenated substances</i>	36
A.6.4.5 <i>Plastics with chlorine and bromine as part of the polymer</i>	38
A.6.4.6 <i>Information regarding plastics and flame retarding agents</i>	40
A.6.5 PRODUCT LIFETIME.....	42
A.6.5.1 <i>Warranty and spare parts</i>	42
A.6.6 PREPARATION FOR RECYCLING.....	43
A.6.6.1 <i>Material coding of plastics</i>	43
A.6.6.2 <i>Variety of plastics</i>	45
A.6.6.3 <i>Take back system</i>	47
A.6.7 PRODUCT PACKAGING.....	49
A.6.7.1 <i>Hazardous substances in product packaging</i>	49
A.6.7.2 <i>Preparation for recycling of product packaging material</i>	50

A.7	CORPORATE SOCIAL RESPONSIBILITY	51
A.7.1	CORPORATE SOCIAL RESPONSIBILITY	51
A.7.2	SENIOR MANAGEMENT REPRESENTATIVE	53
R	REFERENCES.....	54
B	TEST METHODS AND CLARIFICATIONS	57
B.0	GENERAL TEST CONDITIONS	57
B.0.1	DEFINITION OF A TEST OBJECT	57
B.0.2	REQUIRED TEST OBJECT INFORMATION	57
B.0.3	CONDITIONS FOR THE EQUIPMENT UNDER TEST	57
B.0.4	TABLET COMPUTER ALIGNMENT FOR TESTING	58
B.0.5	INSTRUMENTS USED FOR TESTING.....	58
B.0.6	SETTINGS OF THE TABLET COMPUTER.....	58
B.0.7	TEST IMAGE/TEST CHARACTER	59
B.0.8	TEST IMAGE AND TEST LUMINANCE SETTING.....	59
B.0.9	TEST REPORT	60
B.1	GENERAL INFORMATION	61
B.1.1	TCO CERTIFIED DOCUMENT.....	61
B.2	VISUAL ERGONOMICS	62
B.2.0	GENERAL TEST CONDITIONS FOR VISUAL ERGONOMICS	62
B.2.0.1	<i>Basic test requirements.....</i>	62
B.2.0.2	<i>Photometric laboratory general requirements</i>	62
B.2.0.3	<i>Power supply and test room climate requirements for testing.....</i>	62
B.2.0.4	<i>Photometric and spectrometric measurements</i>	62
B.2.0.5	<i>Measurement distance</i>	64
B.2.0.6	<i>Stray light</i>	64
B.2.0.7	<i>Overall uncertainty.....</i>	64
B.2.1	IMAGE DETAIL CHARACTERISTICS	65
B.2.1.1	<i>Native display resolution requirements</i>	65
B.2.2	LUMINANCE CHARACTERISTICS	66
B.2.2.1	<i>Luminance level.....</i>	66
B.2.2.2	<i>Luminance uniformity.....</i>	67
B.2.2.3	<i>Luminance uniformity – angular dependence</i>	68
B.2.3	LUMINANCE CONTRAST CHARACTERISTICS.....	72
B.2.3.1	<i>Luminance contrast – characters</i>	72
B.2.3.2	<i>Luminance contrast – angular dependence</i>	77
B.2.4	REFLECTION CHARACTERISTICS.....	78
B.2.4.1	<i>Front frame gloss</i>	78
B.2.5	SCREEN COLOUR CHARACTERISTICS	79
B.2.5.1	<i>Correlated colour temperature (CCT) variation</i>	79
B.2.5.2	<i>Colour uniformity</i>	80
B.2.5.3	<i>RGB settings.....</i>	82
B.2.5.4	<i>Colour uniformity – angular dependence.....</i>	82
B.2.5.5	<i>Colour greyscale linearity.....</i>	85
B.4	EMISSIONS	87
B.4.1	ACOUSTIC NOISE.....	87
B.6	ENVIRONMENTAL REQUIREMENTS	88
B.6.0	GENERAL CLARIFICATION	88
B.6.0.1	<i>Signatures.....</i>	88
B.6.1	PRODUCT DESCRIPTION.....	88
B.6.2	ORGANISATION.....	88
B.6.2.1	<i>Environmental management system certification.....</i>	88
B.6.3	CLIMATE.....	89
B.6.3.1	<i>Energy consumption – external power supply.....</i>	89
B.6.4	ENVIRONMENTALLY HAZARDOUS SUBSTANCES.....	89
B.6.4.1	<i>Mercury (Hg) free.....</i>	89

B.6.4.2	<i>Cadmium (Cd), lead (Pb) and hexavalent chromium (CrVI)</i>	89
B.6.4.3	<i>Halogenated substances</i>	89
B.6.4.4	<i>Non-halogenated substances</i>	90
B.6.4.5	<i>Plastics with chlorine and bromine as part of the polymer</i>	91
B.6.4.6	<i>Information regarding plastics and flame retarding agents</i>	91
B.6.5	PRODUCT LIFETIME	91
B.6.5.1	<i>Warranty and spare parts</i>	91
B.6.6	PREPARATION FOR RECYCLING.....	91
B.6.6.1	<i>Material coding of plastics</i>	91
B.6.6.2	<i>Variety of plastics</i>	91
B.6.6.3	<i>Take back system</i>	92
B.6.7	PRODUCT PACKAGING.....	92
B.6.7.1	<i>Hazardous substances in product packaging</i>	92
B.7	CORPORATE SOCIAL RESPONSIBILITY	93
B.7.1.1	<i>General Clarifications</i>	93

Support (on this document and TCO Certification)

If you would like to certify your products and need support in understanding this document and the certification process, then TCO Development has partners that have laboratories around the world that can clarify this document and assist you with certification in your native language.

Please contact TCO Development for a list of partner laboratories and verifiers:
certification@tcodevelopment.com

Or visit the TCO Development webpage for a list of partner laboratories:
www.tcodevelopment.com

Introduction

TCO Development has, since the end of the 1980s, influenced the development of IT equipment, particularly Visual Display Units (VDUs). Today, TCO Development's international certification system – TCO Certified – makes it easy to choose sustainably designed and produced IT and office equipment. It is a third party certification, Type 1 eco label according to ISO14024. The point of departure for this product group's criteria is the commitment to sustainability, whereby long term economic gains are dependent on social and environmental considerations. The criteria for TCO Certified include environmental and social aspects, and have been broadened from product focus to also include the production phase. This is a result of increased expectations around the world to respect human rights in the production and development of the products. The social responsibility criteria also cover quality aspects of the product, such as ergonomics, emissions and electrical safety. The criteria related to the environment include, for both product and production, aspects, such as energy consumption, content of hazardous materials, preparation for recycling and environmental management system at production sites.

With every major update of the criteria the aim is to extend and tighten the certification in order to keep in pace with technology innovation and development. All updates are a result of cooperation between key stakeholders, such as purchasers, users, producers, and researchers. This criteria document TCO Certified Tablets 2.0, is the second version of TCO Development's certification of Tablet computers. Going forward, subsequent versions, 2.1, 2.2 etc., might be released. However, these are to be considered only as updates within the second version with improved precision of the mandates and test methods.

It is permitted to quote from these criteria (e.g. in procurements), provided that the source is disclosed and the extent of the quotation is consistent with sound copyright practice. For further information, please visit www.tcodevelopment.com.

Stockholm, November 2012

TCO Development

Martin Söderberg

Business Area Manager Computers

A Criteria

A.1 General information

This document contains requirements, test methods and references for Tablet computers with a display size > 4". The intended use of a tablet computers certified according to this criteria document shall not be mobile communication with the product held to the head.

For the purpose of this document a Tablet Computer, Slate Computer or simply “**Tablet**”, is a wireless, portable [computer](#) that is primarily for battery mode usage and has a [touch screen](#) interface. This means that connection to mains via an adapter is considered to be mainly for battery charging purposes and the onscreen virtual keyboard or a digital pen is in place of a physical keyboard.

However, external keyboards are available for Tablets some of which function as docks for the devices. If a detachable keyboard docking station is supplied together with the Tablet for the intention of the product being converted to a notebook computer, then it is considered the product shall be tested according to the latest TCO Certified Notebooks criteria document found at the TCO Development web site.

The aim of this criteria document is to provide relevant test methods and criteria for the actual use of the product. This criteria document has an A- and a B-part. The A-part includes the mandated criteria and the B-part clarifications and test methods.

Compliance to the mandates in this criteria document can be achieved in one of two ways. Those ways are either through a test report or through a verification report.

1. A test report is defined as a report based on:
 - Testing conducted by the laboratory issuing the test report on the product identified in the report.
2. A verification report is defined as a report based on:
 - A test report issued by a different laboratory.
 - Declarations from the Company applying for the certificate.

The alternatives accepted by TCO Development for each criterion can be found under each mandate respectively.

A.1.1 TCO Certified Document

Background

It is necessary that the purchaser of a product that has been certified in accordance with this TCO Certified Tablets receives information concerning the quality, the features and capabilities of the product. This information is based on the viewpoint from the user's perspective that TCO Development represents.

Applicability

All Tablet computers.

References

The contract between TCO Development and the Applicant/Brand owner.

Mandate A.1.1:

A TCO Certified Document written in English or the native language where the product is to be sold shall accompany the product. The document shall describe why these particular requirements have been chosen for the products within the program of TCO Certified Tablets and what is expected to be achieved by them. The document may be provided as an electronic file. An English version of the text can be obtained from TCO Development.

Examples of how the document can accompany the product are presented below:

- A separate printed document.
- As an electronic file or in the user's manual.
- At the manufacturers web site, together with information about the product. A reference to the web site shall accompany the product.

The following information shall be submitted to the verifier at the test laboratory:

A written guarantee that the above mandate is fulfilled. The document shall be signed by the responsible person at the applicant company.

The following information shall be submitted with the application to TCO Development:

A copy of a verification report from a test laboratory approved by TCO Development.

We hereby guarantee that the above mandate is fulfilled.

.....
Product brand name and model/type

.....
Signature

.....
Name and title in block capitals

.....
Date

.....
Company

A.2 Visual ergonomics

Today displays are an essential tool for users in all kinds of environments. Good visual ergonomics is a very important aspect of quality that can also have a direct effect on the health, comfort and performance of the user.

In developing requirements for visual ergonomics, the possible health effects of various parameters have been taken into account. Other features that characterise good quality displays have also been in focus for developing these criteria.

TCO Development used three main methodologies to determine the suitable level for each requirement and the test methods for the visual ergonomics part of the TCO Certified labelling program. One is based on acceptable visual levels, as determined by scientific research. The second is based on statistics from tests carried out in accordance with TCO Development, ISO, MPR regulations and from specialized VDU tests. The third way is based on manufacturers' knowledge and experience, which is invaluable. Manufacturers, consumer groups and other organisations with interests in the visual ergonomics field have contributed with a great deal of valuable information and ideas throughout the development process.

A.2.1 Image detail characteristics

A.2.1.1 Native display resolution requirement

Background

Image quality is negatively affected by a low fill factor, visible "jaggies", poor rendering of details, etc. All of these parameters are related to the resolution of the display. For display resolution characteristics, it is important to take the viewing distance into account.

The viewing distance in this criteria document is defined as $1.5 \times$ the display diagonal, but no less than 400 mm which could be considered as an absolute minimum viewing distance for comfortable viewing. This means that the mandate on resolution is independent of the display size and viewing distance but dependent on the display format. Only the display format needs to be known.

Definition

A *pixel* is the smallest addressable imaging element of the display capable of reproducing a full range of luminance and colours.

The *native display resolution* is the number of pixels in the horizontal direction by the number of pixels in the vertical direction that the display can present.

Applicability

All Tablet computers.

Test procedure

See B.2.1.1.

References

2.

Mandate A.2.1.1:

The *pixel* density shall be ≥ 30 pixels/degree visual angle.

The following information shall be submitted with the application to TCO Development:

A copy of a test report from a test laboratory approved by TCO Development.

A.2.2 Luminance characteristics

A.2.2.1 Luminance level

Background

It shall be possible to set the luminance level according to the lighting conditions of the surroundings. Poor luminance can lead to low contrast and consequently affect legibility and colour discrimination and thus lead to misinterpretations. It shall be possible to set a sufficiently high luminance level with respect to the ambient lighting in order to present a comfortable viewing situation and to avoid eyestrain.

Definition

Luminance being emitted from a particular area is a measure of the luminous intensity per unit area of light travelling in a given direction and falls within a given solid angle.

The unit of luminance is cd/m^2 .

Applicability

All Tablet computers.

Test procedure

See B.2.2.1.

References

1, 2, 18, 22, 28 and 32.

Mandate A.2.2.1:

The maximum *luminance* shall be $\geq 200 \text{ cd/m}^2$. Also applicable for at least one battery mode.

The following information shall be submitted with the application to TCO Development:

A copy of a test report from a test laboratory approved by TCO Development.

A.2.2.2 Luminance uniformity

Background

Image quality is badly affected by non-uniform luminance. When poor luminance uniformity is visible, it can locally affect the contrast and consequently the legibility of information on the display. The areas of deviating luminance can have different sizes and cause varying contour sharpness.

Definition

Luminance uniformity is the capacity of the display to maintain the same luminance level over the whole active screen area. The luminance uniformity is defined as the ratio of maximum to minimum luminance within the fully active screen area.

Applicability

All Tablet computers.

Test procedure

See B.2.2.2.

References

1, 2, 16, 18, 22, 23, 28, 33 and 34.

Mandate A.2.2.2:

Luminance variation across the active screen, the L_{max} to L_{min} ratio, shall be ≤ 1.50 .

The following information shall be submitted with the application to TCO Development:

A copy of a test report from a test laboratory approved by TCO Development.

A.2.2.3 Luminance uniformity - angular-dependence**Background**

The luminance of a display is angular-dependent, i.e. screen luminance decreases when the display is viewed slightly from the side, horizontally or vertically. This can have a negative effect on contrast and can affect the legibility of the display.

Definition

Luminance uniformity – angular dependence, is the capacity of the display to maintain a certain luminance level independently of the viewing direction. The angular-dependent luminance uniformity is defined as the ratio of maximum luminance (L_{\max}) to minimum luminance (L_{\min}) in the specified measurement areas.

Applicability

All Tablet computers.

Test procedure

See B.2.2.3.

References

1, 16, 23, 28, 33 and 34.

Mandate A.2.2.3:

- 1) In landscape mode, when the screen is rotated around the vertical axis through the centre of the screen the mean value of the L_{\max} to L_{\min} ratios at $\pm 30^\circ$ shall be ≤ 3.00
- 2) In landscape mode, when the screen is rotated around the horizontal axis through the centre of the screen the mean value of the L_{\max} to L_{\min} ratios at $\pm 30^\circ$ shall be ≤ 3.00

The following information shall be submitted with the application to TCO Development:

A copy of a test report from a test laboratory approved by TCO Development.

A.2.3 Luminance contrast characteristics

A.2.3.1 Luminance contrast – characters

Background

The degree of contrast is important for legibility and for distinguishing one character from another.

Definition

Luminance contrast – characters is the capacity of the display to maintain an adequate luminance difference between a bright background and dark characters or parts of characters over the whole active area.

Luminance contrast – characters is expressed as the ratio of the L_{\max} to L_{\min} difference over the sum of L_{\max} and L_{\min} , in accordance with Michaelson's formula.

Applicability

All Tablet computers.

Test procedure

See B.2.3.1.

References

2, 16, 19, 23, 24, 28 and 33.

Mandate A.2.3.1:

The character *luminance contrast* shall be ≥ 0.70 measured orthogonally to the screen.

The following information shall be submitted with the application to TCO Development:

A copy of a test report from a test laboratory approved by TCO Development.

A.2.3.2 Luminance contrast – angular dependence**Background**

For displays, the luminance and consequently the contrast on the display is angular-dependent. The luminance variations can influence both the bright white and the dark areas of the screen, causing a change in contrast. This can have a negative effect on the legibility of the display,

Definition

Luminance contrast – angular dependence, is the capability of the display to maintain the same contrast regardless of the direction from which the screen is viewed. Luminance contrast – angular dependence, is expressed as the ratio of the L_{\max} to L_{\min} difference over the sum of L_{\max} and L_{\min} , in accordance with Michaelson's formula. It is measured at two different angles.

Applicability

All Tablet computers.

Test procedure

See B.2.3.2.

References

2 16, 20, 24, 29 and 34.

Mandate A.2.3.2:

In landscape mode, the *luminance contrast-angular dependence* shall be ≥ 0.80 at $\pm 30^\circ$ horizontally from the viewing direction (rotated around the vertical axis through the centre of the screen).

The following information shall be submitted with the application to TCO Development:

A copy of a test report from a test laboratory approved by TCO Development.

A.2.4 Reflection characteristics

A.2.4.1 Front frame gloss

Background

The bezels gloss influences visual comfort and legibility by drawing attention away from the visual task at hand. The higher the gloss value the more likely it is that the surface will create irritating specular reflections (mirror-like reflections) from ambient lighting. If the gloss value is high enough, the problem of reflection images can occur.

However, in a controlled ambient light, reflections can be avoided by changing light intensity or moving light sources or the Tablet computer, making the problem with gloss less relevant.

Definition

Gloss is a measure of how a light beam, physically described as luminous flux, is scattered at the surface when incident against that surface. Gloss is a function of the directional reflectance properties of a surface.

Applicability

All Tablet computers.

Test procedure

See B.2.4.1.

References

5, 6 and 7.

Mandate A.2.4.1:

For Tablet computer bezels that have a *gloss* value $G(60^\circ) > 30$ gloss units the following consideration note for the placement of the Tablet shall be given in the language of the user manual.

“For Tablets with glossy bezels the user should consider the placement of the Tablet as the bezel may cause disturbing reflections from surrounding light and bright surfaces.”

The following information shall be submitted to the verifier at the test laboratory:

For > 30 gloss units a written guarantee that the above mandate is fulfilled must be provided. The document shall be signed by the responsible person at the applicant company.

The following information shall be submitted with the application to TCO Development:

A copy of a test report and a verification report from a test laboratory approved by TCO Development.

We hereby guarantee that the above mandate is fulfilled.

.....
Product brand and model name

.....
Signature

.....
Name and title in block capitals

.....
Date

.....
Company

A.2.5 Screen colour characteristics

A.2.5.1 Correlated colour temperature, CCT variation

Background

If the display is equipped with pre-set correlated colour temperature setting the user has the right to expect that the colour hue of the correlated colour temperature setting is close to the one indicated by the pre-set. This makes it possible to more accurately evaluate the colour of an image on the display compared to real scenes or prints.

Physical measurements of colour stimuli can only give an indication of the colour appearance in a practical situation. The colour of the frame, the spectral composition of the lighting, the colour of various areas in the visual field, and the complexity of brightness variations in the visual field all influence the colour appearance of an image.

Normal daylight has a correlated colour temperature in the range 5000 – 10000 K.

Definition

The *correlated colour temperature* is a measure of the perceived screen colour expressed in kelvin (K).

Applicability

All Tablet computers.

Test procedure

See B.2.5.1.

References

2, 3, 4, 8, 9, 10, 11, 14, 15, 25, 26, 27, 29, 31 and 35.

Mandate A.2.5.1:

The *correlated colour temperature* of the active display shall be in the range 5000K to 10000K.

For Tablet computers with Correlated Colour Temperature pre-sets, each pre-set shall have a colour difference $\Delta u'v' \leq 0.012$ when compared to CIE u' and v' chromaticity co-ordinates for corresponding correlated colour temperatures.

The following information shall be submitted with the application to TCO Development:

A copy of a test report from a test laboratory approved by TCO Development.

A.2.5.2 Colour uniformity

Background

The human visual system is very sensitive to changes in colour hue in white and grey areas. Since the white or grey colour hues are the background on which most colours are judged, the white or grey areas are the reference colours on the screen.

Patches of colour variation on an active white or grey screen could reduce the contrast locally, be disturbing and affect the legibility, colour rendering and colour differentiation.

Definition

The *colour uniformity* of a display is the capability to maintain the same colour in any part of the screen.

Applicability

All Tablet computers.

Test procedure

See B.2.5.2.

References

2, 8, 14, 15, 24, 26, 30 and 36.

Mandate A.2.5.2:

The maximum colour deviation between measured active areas on the screen that are intended to maintain the same colour shall be $\Delta u'v' \leq 0.012$

The following information shall be submitted with the application to TCO Development:

A copy of a test report from a test laboratory approved by TCO Development.

A.2.5.3 RGB settings

Background

Accurate colour rendering is important when realistic colour images or colour presentations are presented on the display. Poor colour rendering can lead to poor legibility and misinterpretation. The u' and v' chromaticity co-ordinates of the primary colours red (R), green (G) and blue (B) of the screen shall aim at values given in international IEC, EBU and ITU standards. The u' and v' chromaticity co-ordinates of the primary colours R, G and B form a triangle in the CIE 1976 uniform chromaticity scale diagram. The larger the area of the triangle, the wider the range of colours the screen is capable of presenting.

The colour characteristics of a display are based on the visual appearance of the displays primary colour stimuli, the R, G, B-stimuli.

Applicability

All Tablet computers.

Test procedure

See B.2.5.3.

References

3, 4, 8, 9, 10, 11, 12, 13, 14, 15, 26, 27, 29, 31 and 35.

Mandate A.2.5.3:						
The minimum colour triangle shall have the following co-ordinates:						
	Red		Green		Blue	
Co-ordinate	u'	v'	u'	v'	u'	v'
Requirement	≥ 0.375	≥ 0.503	≤ 0.160	≥ 0.548	≥ 0.135	≤ 0.305
The following information shall be submitted with the application to TCO Development:						
A copy of a test report from a test laboratory approved by TCO Development.						

A.2.5.4 Colour uniformity – angular dependence

Background

The human visual system is very sensitive to changes in colour hue in white and grey areas. Since the white or grey colour hues are the background on which most colours are judged, the white or grey areas are the reference colours on the screen. Angular-dependent colour variations on an active white or grey screen could be disturbing and affect legibility, colour rendering and colour differentiation.

Definition

The *colour uniformity – angular dependence* of a display is the capability of the display to maintain constant colour over the screen surface depending of the direction from which the screen is viewed.

Applicability

All Tablet computers.

Test procedure

See B.2.5.4.

References

2, 8, 14, 15, 24, 26, 30 and 36.

Mandate A.2.5.4:

In landscape mode, the $\Delta u'v'$ between areas on the left side and the right side of the screen when it is positioned at $+30^\circ$ and at -30° horizontally to the screen normal (rotated around the vertical axis through the centre of the screen) shall be ≤ 0.025

The following information shall be submitted with the application to TCO Development:

A copy of a test report from a test laboratory approved by TCO Development.

A.2.5.5 Colour greyscale linearity

Background

A well-tuned colour greyscale is the basis for good colour rendering on the screen. This is measured via steps in a greyscale on the screen. Each greyscale step shall have similar colour hues in order to simplify colour interpretation and, to avoid confusion for the user, only the luminance shall vary.

Definition

Colour greyscale linearity is the capability of the screen to maintain the same u' , v' co-ordinates of a greyscale pattern at all greyscale levels, i.e. only the luminance shall change from one greyscale step to the next.

Applicability

All Tablet computers.

Test procedure

See B.2.5.5.

References

2, 8, 14, 15, 24, 26, 30 and 36.

Mandate A.2.5.5:						
Table A.2.5.5						
Greyscale	Maximum $\Delta u'v'$ difference					
	255	225	195	165	135	105
255	0					
225	0.045	0				
195	0.045	0.045	0			
165	0.050	0.050	0.050	0		
135	0.055	0.055	0.050	0.050	0	
105	0.055	0.055	0.055	0.055	0.050	0

The $\Delta u'v' \leq$ the maximum allowed difference for each step according to table A.2.5.5

The following information shall be submitted with the application to TCO Development:

A copy of a test report from a test laboratory approved by TCO Development.

A.4 Emissions

A.4.3 Acoustic noise

Background

Acoustic noise from fans, hard disk etc. can be annoying. To prevent such annoyance, the aim shall be that Tablet computers shall cause a minimum of noise during usage. Many end-users are sensitive to noise with different characteristics. To give the end-user a possibility to choose a product with a comfortable noise level and frequency characteristics generated by a product this information should be declared together with all other data related to a certain product.

Definitions

To be able to provide information about acoustic noise levels that permits comparison between different Tablet computers the declared A-weighted sound power level (L_{WAd}) in operating and idling mode measured in accordance with ISO 9296 p.4.4.1 in bels (B) shall be reported. The following definitions apply:

Sound power level (L_W):

Total emitted sound power from a sound source, given in bels (B) and with the reference 1 pW .

A-weighting:

The measured linear sound level (sound pressure or sound power) weighted against the sensitivity of the human ear for different frequencies (A-curve).

Declared A-weighted sound power level (L_{WAd}): in bels (B). Defined in accordance with ISO 9296 3.2.5.

Operating mode. A condition in which the system and hard disk drive shall be operated in accordance with ECMA-74 C.15.3.2 and C.9.3.2.

Idling mode. A condition in which the system shall be operated in accordance with ECMA-74 C.15.3.1.

Applicability

All Tablet computers with integrated moving parts.

Test procedure

See B 4.3 and ISO 7779:2010

References

37-43.

Mandate:

For Tablet computers with integrated moving parts, such as motor driven hdd, fans, etc.

1. The *declared A-weighted sound power level (LWAd)* shall not exceed:

Operating mode: 3.9 B

Idling mode: 3.5B

If the product does not emit prominent discrete tones according to procedures specified in ECMA 74 Annex D a higher declared A-weighted sound power level (LWAd) is accepted but shall not exceed:

Operating mode: 4.2B

Idling mode: 3.8B

2. The A-weighted sound power level for a product shall be declared in the product data sheet and/or in any other product descriptions.

The following information shall be submitted with the application to TCO Development:

A copy of a test report from a test laboratory approved by TCO Development

A.5 Electrical safety

A.5.1 Electrical safety

Background

Electrical safety concerns the electrical design of apparatus with respect to its electrical insulation and other arrangements that are intended to prevent accidents resulting from contact with live components, and the risk of fire or explosion as a result of electrical flash-over due to inadequate or faulty electrical insulation.

Applicability

All Tablet computers with built-in power supplies as well as any separate power supply intended to be used together with the Tablet computer.

References

44.

Mandate A.5.1:

The Tablet computer and the internal or external power supply/supplies shall be certified in accordance with EN/IEC 60950 or EN/EIC 60065.

The following information shall be submitted with the application to TCO Development:

A copy of the CB certificate or national certificate from a CB member (NCB).

A.6 Environmental requirements

The TCO Certified requirements combine a unique integrated balance of indoor and outdoor environmental issues. Achieving a good working environment should not be at the expense of the natural environment. This document details the environmental requirements of the TCO Certified label.

The Environmental requirements are divided into the following sections:

1. Organisation – requirements focusing on the production phase, environmental management and Corporate Social Responsibility (CSR).
2. Climate – energy consumption, one of the most important issues in the environmental impact of IT products.
3. Hazardous Substances – heavy metals, flame retardants, plastics.
4. Product Lifetime – factors to extend the life of the product.
5. Preparation for Recycling – factors to stimulate recycling.
6. Packaging – hazardous substance content and recycling.

Potential environmental effects are evident at each stage of the product life cycle. Due to the complexity of the production of ICT products, it is often most effective to refer to indirect requirements on the production such as requirements for an environmental management system. Should a more direct quality-assured system for manufacturing processes become possible, then TCO Development would consider that option for future requirements. The environmental requirements TCO Development has focused on are those that we consider most relevant to the product group. They have also proved to be attainable in volume production and are verifiable. Future updates of the criteria will likely focus on hazardous substances, CSR and climate issues.

All requirements except section *A.6.3 Climate* shall be verified by sending the requested information to an environmental verifier at a test laboratory approved by TCO Development. The energy consumption requirements in section *A.6.3* shall be tested at a test laboratory approved by TCO Development.

A.6.1 Product description

Background

The aim of this product description is to provide information about the product that is to be reviewed for compliance with the environmentally related requirements of Section A.6 and also for information collection.

Definitions

Marking plate /Marking label is the label that contains the product's electrical rating in terms of voltage, frequency, current and the manufacturer's name, trademark or identification mark together with the manufacturer's model or type reference. The label shall be in accordance with IEC 60 950:1 clause 1.7.1.

Applicability

All Tablet computers and the equipment specified in requirement A.1.1 supplied with them.

Clarification

B.6.1

References

44

Mandate A.6.1:

A product declaration shall be provided for the Tablet computer.

The following information shall be submitted to an approved verifier:

1. The declaration below, completed where applicable.
2. A copy of the *marking plate* for the Tablet computer and external power supply.

The information submitted shall be signed by the responsible person at the applicant company.

The following information shall be submitted with the application to TCO Development:

A copy of a verification report from a verifier at a laboratory approved by TCO Development and a copy of the marking label.

Declaration of a Tablet computer.

Tablet computer	Information
Manufacturer	
Brand name	
Brand Owner	
Type/Model name	
Product Family name	

All possible options of the parts of the Tablet computer stated below shall be declared in the table below. (Please increase the number of rows when necessary).

Panel	Information
Brand name	
Model name	
Size and technology (e.g. TN type)	

External power supply: Brand & model name	Rating and Class

Battery: Brand & model name	Technology (e.g. Li-ion), rating & characteristics

TCO Certified Certificate Holder.....

We hereby guarantee that the above mandate is fulfilled.

.....
Product brand name and model name

.....
Signature

.....
Name and title in block capitals

.....
Date

.....
Company

A.6.2 Organisation

A.6.2.1 Environmental management system certification

Background

A certified environmental management system is proof that the company shows concern for the environment and has chosen to work in a systematic way with constant improvement of the environmental performance of the company and its products in focus. A certified environmental management system includes external independent reviews.

Definitions

Manufacturing plant is the site where the final assembly of the product is taking place.

Applicability

Company or companies manufacturing the Tablet computer.

Clarification

B.6.2.1

References

45 and 46.

Mandate A.6.2.1:

Each *manufacturing plant* must be certified in accordance with ISO 14001, or EMAS registered. If the product is manufactured by a third party, it is this company that shall be certified or registered.

If the *manufacturing plant* does not have an ISO 14001 certificate or EMAS registration at the time of application, the *manufacturing plant* is given a 12-month grace period to obtain ISO14001 certification or EMAS registration.

The following information shall be submitted to an approved verifier:

1. A document showing the names and addresses of the manufacturing plants.
2. Copy of the ISO 14001 certificate or EMAS registration or, when not available, an estimated date of certification/registration.
3. A written guarantee that the certificate/registration is valid and that the mandate above is fulfilled, signed by the responsible person at the applicant company.

The following information shall be submitted with the application to TCO Development:

A copy of a verification report from a verifier approved by TCO Development.

We hereby guarantee that the above mandate is fulfilled.

.....
Product brand name and model name

.....
Signature

.....
Name and title in block capitals

.....
Date

.....
Company

A.6.3 Climate

A.6.3.1 Energy consumption

Background

Energy is the single most important topic in the issue of climate change. Energy efficient equipment is an important and effective way to fight climate change. With an ever-increasing volume of IT equipment in use, the efficiency of each product is vital. To reduce energy consumption from the Tablet the external power supply shall comply with the International Efficiency Marking Protocol for External Power Supplies.

Applicability

All external power supplies.

Clarification

B.6.3.1

References

52.

Mandate A.6.3.1:

The external power supply shall meet at least the International Efficiency Protocol requirement for level V

The following information shall be submitted to the verifier at the test laboratory:

A copy of the marking plate for the external power supply

The following information shall be submitted with the application to TCO Development:

A copy of the marking plate for the external power supply

A.6.4 Environmentally hazardous substances

A.6.4.1 Mercury (Hg) free product

Background

The effects of mercury (Hg) are well documented as an environmental hazardous substance. EU regulates mercury in the RoHS directive, however exempting the use of mercury in the backlighting of FPDs. Today the LED backlight technology for FPDs makes it possible to go beyond the RoHS Directive and ban the use of mercury altogether.

Applicability

All Tablet computers.

Clarification

B.6.4.1

References

54.

Mandate A.6.4.1:

The product shall not contain mercury.

For maximum concentration values: see B.6.4.1.

The following information shall be submitted to an approved verifier:

A written guarantee that the above mandate is fulfilled. The guarantee shall be signed by the responsible person at the applicant company.

The following information shall be submitted with the application to TCO Development:

A copy of a verification report from a verifier approved by TCO Development.

We hereby guarantee that the above mandate is fulfilled.

.....
Product brand name and model name

.....
Signature

.....
Name and title in block capitals

.....
Date

.....
Company

A.6.4.2 Cadmium (Cd), lead (Pb) and hexavalent chromium (Cr6)

Background

The effects of the listed substances are well documented as environmental hazardous substances. EU regulated these substances in the RoHS directive (2002/95/EC).

Applicability

All Tablet computers.

Clarification

B.6.4.2

References

53 and 54.

Mandate A.6.4.2:

The Tablet computer shall not contain cadmium, lead and hexavalent chromium.

Note: This applies to components, parts, and raw materials in all assemblies and sub-assemblies of the product e.g. paint, surface treatment, plastics and electronic components.

For maximum concentration values: See B.6.4.2

The following information shall be submitted to an approved verifier:

A written guarantee that the mandate above is fulfilled. The guarantee shall be signed by the responsible person at the applicant company.

The following information shall be submitted with the application to TCO Development:

A copy of a verification report from a verifier approved by TCO Development.

We hereby guarantee that the above mandate is fulfilled.

.....
 Product brand name and model name

.....
 Signature

.....
 Name and title in block capitals

.....
 Date

.....
 Company

A.6.4.3 Halogenated substances

Background

Brominated and chlorinated flame retardants and other halogenated substances are often persistent, can bioaccumulate in living organisms and have been detected in flora and fauna.

A series of international elimination activities in respect to brominated and chlorinated flame retardants is currently in progress within several national and international bodies, e.g. EU, OECD, North Sea Conference.

Definitions

Plastic parts are parts made mainly of plastics, e.g. the housing. Parts containing other materials in any significant amounts, e.g. cables with metal conductors, are not included in the definition.

Printed wiring board laminate is a printed board that provides point-to-point connections but not printed components in a predetermined configuration on a common base.

Applicability

All Tablet computers.

Clarification

B.6.4.3

References

55.

Mandate A.6.4.3:

1. *Plastic parts* weighing more than 25 grams shall not contain flame retardants or plasticizers that contain organically bound bromine or chlorine.

Note: The requirement applies to plastic parts in all assemblies and sub-assemblies. Exempted are *printed wiring board laminates*, electronic components and all kinds of cable insulation.

2. The Tablet computer shall not contain PBB, PBDE and HBCDD.

Note: The requirements apply to components, parts and raw materials in all assemblies and sub-assemblies of the product e.g. batteries, paint, surface treatment, plastics and electronic components.

For maximum concentration values: See B.6.4.3

The following information shall be submitted to an approved verifier:

A written guarantee that the above mandate is fulfilled. The guarantee shall be signed by the responsible person at the applicant company.

The following information shall be submitted with the application to TCO Development:

A copy of a verification report from a verifier approved by TCO Development.

We hereby guarantee that the above mandate is fulfilled.

.....
Product brand name and model name

.....
Signature

.....
Name and title in block capitals

.....
Date

.....
Company

A.6.4.4 Non-halogenated substances

Background

The purpose of this mandate is to ensure that the phase out of halogenated flame retardants not risk a shift towards substances with other known hazardous effects.

The mandate focuses on 14 hazardous statements. All substances relevant for the IT industry that have been assigned a hazardous statement and where there are less hazardous commercially available alternatives will be restricted from TCO Certified products. The list of these substances is evaluated and revised in each new version of the criteria document.

To date in this version, only harmonized substances found on the European chemical Substance Information System (ESIS) at: <http://esis.jrc.ec.europa.eu/> have been restricted. In the future version of the criteria document TCO Development have the ambition to also restrict substances that are not at this time harmonized. An example of such not yet harmonized substances may be found in B.6.4.3.

Definitions

Plastic parts are parts made mainly of plastics, e.g. the housing. Parts containing other materials in any significant amounts, e.g. cables with metal conductors, are not included in the definition.

Printed wiring board laminate is a printed board that provides point-to-point connections but not printed components in a predetermined configuration on a common base.

Hazardous statements (Risk phrases) according to EU Regulation 1272/2008 (EU Directive 67/548/EEC)

- H340 (R46) (may cause heritable genetic damage)
- H341 (R68) (suspected of causing genetic defects)
- H350 (R45) (may cause cancer)
- H350i (R49) (may cause cancer by inhalation)
- H351 (R40) (limited evidence of a carcinogenic effect)
- H360F (R60) (may impair fertility)
- H360D (R61) (may cause harm to the unborn child)
- H361d (R63) (suspected of damaging the unborn child)
- H361f (R62) (suspected of damaging fertility)
- H362 (R64) (may cause harm to breast-fed children)
- H372 (R48/25/24/23) (danger of serious damage by prolonged exposure)
- H373 (R48/20/21/22) (may cause damage to organs through prolonged exposure)
- H400 and H410 (R50/R53) (very toxic to aquatic organisms / may cause long-term adverse effects in the aquatic environment)
- H411 (R51/53) (Toxic to aquatic life with long-lasting effects)

Applicability

All Tablet computers.

Clarification

B.6.4.4

References:

56 and 57.

Mandate A.6.4.4:

The following non halogenated flame retardants shall not be used in plastic parts weighing more than 25 grams:

- Antimony(III) oxide (Sb₂O₃), CAS: 1309-64-4
- Tri-o-cresyl phosphate, CAS: 78-30-8

Exempted are *printed wiring board laminates*, electronic components and all kinds of cable insulation.

For maximum concentration values: See B.6.4.4

The following information shall be submitted to an approved verifier:

A written guarantee that the above mandate is fulfilled. The guarantee shall be signed by the responsible person at the applicant company.

The following information shall be submitted with the application to TCO Development:

A copy of a verification report from a verifier approved by TCO Development.

We hereby guarantee that the above mandate is fulfilled.

.....
Product brand name and model name

.....
Signature

.....
Name and title in block capitals

.....
Date

.....
Company

A.6.4.5 Plastics with chlorine and bromine as part of the polymer**Background**

PVC is by far the most common halogen containing plastic. There are however other plastics that contain chlorine or bromine in the plastic itself. As the requirement concerning permissible flame retardants tightens, the risk increases that halogenated plastics will become more common. TCO Development sees a future environmental risk with such a development.

PVC is a much-debated plastic that can pose environmental problems in most parts of its life cycle. The magnitude of the environmental problems relating to PVC differs depending on the environmental status of a particular manufacturing facility and the uses of additives. At present there are very limited possibilities to distinguish between harmful and less harmful production facilities for PVC.

Definitions

Plastic parts are parts made mainly of plastics, e.g. the housing. Parts containing other materials in any significant amounts, e.g. cables with metal conductors, are not included in the definition.

Printed wiring board laminate is a printed board that provides point-to-point connections but not printed components in a predetermined configuration on a common base.

Applicability

All Tablet computers.

Clarification

B.6.4.5

References

54 and 58.

Mandate A.6.4.5:

Plastic parts in the Tablet computer weighing more than 25 grams shall not contain chlorine or bromine as a part of the polymer.

Note that *printed wiring board laminates*, and all kinds of internal and external cable insulation are not considered to be part of *plastic parts* and are therefore not included in the mandate.

The following information shall be submitted to an approved verifier:

A written guarantee that the above mandate is fulfilled. The guarantee shall be signed by the responsible person at the applicant company.

The following information shall be submitted with the application to TCO Development:

A copy of a verification report from a verifier approved by TCO Development.

We hereby guarantee that the above mandate is fulfilled.

.....
Product brand name and model name

.....
Signature

.....
Name and title in block capitals

.....
Date

.....
Company

A.6.4.6 Information regarding plastics and flame retarding agents

Background

This requirement is intended to give information about the plastics and flame retarding agents in the product to be reviewed for compliance with the environment requirements in this criteria document.

Definitions

Plastic parts are parts made mainly of plastics, e.g. the housing. Parts containing other materials in any significant amounts, e.g. cables with metal conductors, are not included in the definition.

Printed wiring board laminate is a printed board that provides point-to-point connections but not printed components in a predetermined configuration on a common base.

Applicability

All Tablet computers.

References

55 and 59.

Mandate A.6.4.6:

The material specifications shall be provided for *plastic parts* and *printed wiring board laminates* weighing more than 25 grams. Plasticizers or flame retardants that have concentrations above 1% by weight in the plastic part shall be stated, in accordance with ISO 1043-3 or ISO 1043-4.

The following information shall be submitted to an approved verifier:

The table below shall be completed and the guarantee signed by the responsible person at the applicant company.

Manufacturers of plastic materials who consider such information confidential may submit the information to an eco-verifier approved by TCO Development.

The following information shall be submitted with the application to TCO Development:

A copy of a verification report from a verifier approved by TCO Development.

Plastic part and PWB name	Weight in grams	Type of plastic	Plastic manufacturer name	Plastic model name	Flame retardant/ plasticizer type	Flame retardant/plasticizer CAS number*)	Plastic label code **)

*) Chemical Abstract Service number www.cas.org

**) Labelling according to ISO 11469

We hereby guarantee that the above mandate is fulfilled.

.....
Product brand name and model name

.....
Signature

.....
Name and title in block capitals

.....
Date

.....
Company

A.6.5 Product lifetime

A.6.5.1 Warranty and spare parts

Background

A longer product lifetime has a significant positive contribution to resource use as well as the reduction of air and water pollution. A pre-condition for prolonged lifetime is that the product is of high quality, which is supported by good guarantees. Another requirement is the availability of spare parts for the product once it is taken out of production.

Definitions

Brand owner is the company that owns the brand name visible on the product.

Spare parts are those parts which have the potential to fail during the normal use of the product. Product parts whose life cycle usually exceeds the average usual life of the product need not be provisioned as spare parts.

Applicability

All Tablet computers.

Clarification

B.6.5.1

Mandate A.6.5.1:

The *brand owner* shall provide a product warranty for a period of at least one year.

The *brand owner* shall guarantee the availability of *spare parts* for at least three years from the time that production ceases.

The following information shall be submitted to an approved verifier:

A written guarantee that the above mandate is fulfilled. The guarantee shall be signed by the responsible person at the *brand owner* company.

The following information shall be submitted with the application to TCO Development:

A copy of a verification report from a verifier approved by TCO Development.

We hereby guarantee that the above mandate is fulfilled.

..... Product brand name Model name(s) or "All products"
..... Signature Name and title in block capitals
..... Date (Declaration valid 1 year from date) Brand Owner Company

A.6.6 Preparation for Recycling

A.6.6.1 Material coding of plastics

Background

Recycling of used electronic products is an important environmental issue. Material recycling and reuse are the best options from an environmental point of view. With material coding there is a better possibility for plastics to be recycled and used in new IT equipment.

Definitions

Plastic parts are parts made mainly of plastics, e.g. the housing. Parts containing other materials in any significant amounts, e.g. cables with metal conductors, are not included in the definition.

Printed wiring board laminate is a printed board that provides point-to-point connections but not printed components in a predetermined configuration on a common base.

Applicability

All Tablet computers.

Clarification

B.6.6.1

References

56, 59 and 60.

Mandate A.6.6.1:

Plastic parts weighing more than 25 grams shall be material coded in accordance with ISO 11469 and ISO 1043-1, -2, -3, -4. Such parts shall be listed in the table at Section A.6.4.5.

Exempted are *printed wiring board laminates*.

The following information shall be submitted to an approved verifier:

A written guarantee that the above mandate is fulfilled. The guarantee shall be signed by the responsible person at the applicant company.

The following information shall be submitted with the application to TCO Development:

A copy of a verification report from a verifier approved by TCO Development.

We hereby guarantee that the above mandate is fulfilled.

.....
Product brand name and model name

.....
Signature

.....
Name and title in block capitals

.....
Date

.....
Company

A 6.6.2 Variety of plastics

Background

Recycling of used electronic products is an important environmental issue. Material recycling and reuse are the best options from an environmental point of view. Therefore TCO Development presents requirements that facilitate material recycling.

Applicability

All Tablet computers.

Clarification

B.6.6.2

Definitions

Types of *plastic material* (using the abbreviation terms, symbols and concepts for plastics in ISO 1043 Part 1, 2, 3, and 4) are:

- Basic polymers
- Mixtures of polymers
- Basic polymers with flame retardants
- Mixtures of polymers with flame retardants

References

59 and 60.

Mandate A.6.6.2:

No more than two different types of *plastic materials* are accepted for parts weighing more than 25 grams.

The following information shall be submitted to an approved verifier:

A written guarantee that the above mandate is fulfilled. The guarantee shall be signed by a responsible person at the applicant company.

The following information shall be submitted with the application to TCO Development:

A copy of a verification report from a verifier approved by TCO Development.

We hereby guarantee that the above mandate is fulfilled.

.....
Product brand name and model name

.....
Signature

.....
Name and title in block capitals

.....
Date

.....
Company

A.6.6.3 Take back system

Background

The amount of electronic waste in the world today is enormous and a growing environmental problem. It is important that manufacturers provide mechanisms to take back their equipment at end-of-life under the principle of individual producer responsibility wherein each producer must be financially responsible for managing its own brand products at end-of-life. Currently much electronic waste is being exported to developing countries where it is managed unsustainably and disproportionately burdens developing countries with this global environmental burden. The Basel Convention and its decisions govern the export of many types of electronic waste. However not all countries have properly implemented these decisions. With this mandate TCO Development aims to put more influence into spreading better electronic waste management practice to more countries.

Definition

Brand owner is the company that owns the brand name visible on the product.

Take back system is a system that makes sure that the customer can return used products to be recycled. The system can be with or without a fee.

Environmentally acceptable recycling methods are:

- Product and component reuse
- Material recycling with secured handling of hazardous chemicals and heavy metals
- Pollution-controlled energy recovery of parts of the product

Applicability

All Tablet computers.

Clarification

B.6.6.3

References

61.

Mandate A.6.6.3

The *brand owner* (or its representative, associated company or affiliate) shall offer their customers the option to return used products for *environmentally acceptable recycling methods* in at least one market where the product is sold and where electronics take back regulation is not in practice at the date of application.

The following information shall be submitted to an approved verifier:

The information stated in the list below shall be submitted and the guarantee signed by the responsible person at the *brand owner* company.

The following information shall be submitted with the application to TCO Development:

A copy of a verification report from a verifier approved by TCO Development.

The requirement can be fulfilled by one of the following options (to be verified):

- 1. Product only sold on markets with WEEE legislation or similar
- 2. World-wide product take back*
- 3. Take back is offered on one additional market where the product is sold and lacks WEEE legislation*
Name of market.....

*The brand owner shall also submit a short description, to an approved eco-verifier, of the take back system or reference to the representative, associated company or affiliate taking care of the take-back system

We hereby guarantee that the above mandate is fulfilled.

..... Product brand name Model name(s) or "All products"
..... Signature Name and title in block capitals
..... Date (Declaration valid 1 year from date) Brand Owner Company

A.6.7 Product packaging

A.6.7.1 Hazardous substances in product packaging

Background

Packaging constitutes a well-known environmental problem and is regulated in many countries worldwide. Packaging material has a short lifetime and generates large volumes of waste.

There are three main areas of concern, content of hazardous substances, use of resources and transport volume.

Applicability

All packaging material.

Definition

Brand owner is the company that owns the brand name visible on the product.

Clarification

B.6.7.1

References

62.

Mandate A.6.7.1:

The packaging material shall not contain lead (Pb), cadmium (Cd), mercury (Hg) or hexavalent chromium (Cr6).

Plastic packaging material shall not contain organically bound halogens.

The following information shall be submitted to an approved verifier:

A written guarantee that the mandate above is fulfilled. The guarantee shall be signed by the responsible person at the *brand owner* company.

The following information shall be submitted with the application to TCO Development:

A copy of a verification report from a verifier approved by TCO Development.

We hereby guarantee that the above mandate is fulfilled.

..... Product brand name Model name(s) or "All products"
..... Signature Name and title in block capitals
..... Date (Declaration valid 1 year from date) Brand Owner Company

A.6.7.2 Preparation for recycling of product packaging material

Background

Packaging constitutes a well-known environmental problem and is regulated in many countries worldwide. Packaging material has a short lifetime and generates large volumes of waste.

There are three main areas of concern, content of hazardous substances, use of resources and transport volume.

Applicability

All packaging material.

Definition

Brand owner is the company that owns the brand name visible on the product.

Mandate A.6.7.2:

Non-reusable packaging components weighing more than 25 grams shall be possible to separate into single material types without the use of tools.

Exempted is reusable packaging.

The following information shall be submitted to an approved verifier:

A written guarantee that the mandate above is fulfilled. The guarantee shall be signed by the responsible person at the *brand owner* company.

The following information shall be submitted with the application to TCO Development:

A copy of a verification report from a verifier approved by TCO Development.

We hereby guarantee that the above mandate is fulfilled.

..... Product brand name Model name(s) or "All products"
..... Signature Name and title in block capitals
..... Date (Declaration valid 1 year from date) Brand Owner Company

A.7 Corporate Social Responsibility

A.7.1 Corporate Social Responsibility

Background

Expectations for Corporate Social Responsibility (CSR) performance are increasing from customers and institutions. As part of the development towards being a true sustainability label, TCO Development is now introducing an extended mandate regarding supply chain responsibility.

TCO Development is supporting the OECD Guidelines for Multinational Enterprises ISO 26000 as references for working with social responsibility.

The CSR component of the TCO standard focuses on working conditions in the production of the TCO certified products.

TCO Development is primarily verifying the Brand owner's procedures for promoting legal and human labour standards in the supply chain as specified in the mandate but reserves the right to conduct supplier audits at production facilities. Also, the Brand owner should demonstrate commitment to corporate social responsibility.

Definitions

Brand owner: The company or organization owning or controlling the *Brand Name*.

Brand Name: The name or sign, including but not limited to a trademark or company name, used to identify, amongst users and customers, the manufacturer or seller of a Product.

1st tier production facility: Manufacturing plant where the final assembly of the TCO certified product is taking place.

Applicability

The Brand owner.

Clarification

B.7.1.1 – B.7.1.6

References

48, 49 and 50.

A.7.2 Senior Management Representative

Background

It is extremely beneficial that an open and transparent dialogue between the brand owner and TCO Development exist for the monitoring of the standards or when it is otherwise necessary to discuss issues concerning working conditions at manufacturing sites. A contact person responsible for the organization's efforts to enforce the CSR requirements needs to be consistently available for dialogue with TCO Development.

Definitions

Brand owner: The company or organization owning or controlling the *Brand Name*.

Brand Name: The name or sign, including but not limited to a trademark or company name, used to identify, amongst users and customers, the manufacturer or seller of a Product.

Applicability

The Brand owner.

Clarification

B.7.2

Mandate A.7.2:

The Brand owner shall have an appointed senior management representative who, irrespective of other responsibilities, shall ensure that the requirements of this mandate are met. The contact details of this person shall be submitted and the person shall be available for dialogue in English with TCO development throughout the certification period.

The following information shall be submitted to a verifier approved by TCO Development:

1. Name, Title, Telephone Number and Email Address of the senior management representative available for dialogue in English with TCO Development around CSR issues.
2. A written guarantee that the above mandate is fulfilled. The guarantee shall be signed by the responsible person at the Brand owner company

The following information shall be submitted with the application to TCO Development: A copy of a verification report from a verifier approved by TCO Development.

We hereby guarantee that the above mandate is fulfilled.

Product brand name	Model name(s) or "All products"
Signature	Name and title in block capitals
Date (Declaration valid 1 year from date)	Brand Owner Company

R References

International standard organisations referred to in the reference list below and their Web sites.

- ASTM, American Society for Testing and Materials, <http://www.astm.org/>
 - CIE, Commission Internationale de l'Eclairage, International Commission on Illumination, www.cie.co.at/cie/
 - DIN, Deutsches Institut für Normung e. V., www2.din.de
 - EBU, European Broadcasting Union, http://www.ebu.ch/tech_info.html
 - IEC, International Electrotechnical Commission, www.iec.ch
 - ISO, International Organization for Standardization, <http://www.iso.org/>
 - ITU, International Telecommunication Union www.itu.int/home/index.html
 - SMTPE, Society of Motion Picture Television Engineers, www.smtpe.org
 - VESA, Video Electronics Standards Association, www.vesa.org
1. CIE Publication 69 (1987), Methods of characterizing illuminance meters and luminance meters: performance characteristics and specifications.
 2. Flat Panel Display Measurements Standard, (M), Version 2.0, VESA - Video Electronics Standards Association Display Metrology Committee. June 1, 2001, CA 95035, Milpitas.
 3. <http://www.w3.org/Graphics/Color/sRGB.html>
 4. SMPTE RP 145-1994: SMPTE C Colour Monitor Colourimetry
 5. ASTM gloss standard D523.
 6. ISO 2813:1994.
 7. DIN 67 530.
 8. CIE Publication 15.2 (1986), Colourimetry, p. 11, p.27-28 and p. 53-54, table 1.3).
 9. IEC 61966-2-1 (1999-10) Multimedia systems and equipment - Colour measurement and management - Part 2-1: Colour management - Default RGB colour space – sRGB.
 10. ITU-R Recommendation BT.470-6: Conventional television systems.
 11. ITU-R Recommendation BT.709-5: Parameter values for the HDTV standards for production and international programme exchange
 12. E.B.U. Standard for chromaticity tolerances for studio monitors Tech. 3213-E August 1975.
 13. SMPTE 170M-1999 Television - Composite Analogue Video Signal - NTSC for Studio Applications.
 14. Hunt, R.W.G. Measuring colour. 3rd edition (1998), Kingsley-Upon-Thames: Fountain Press.
 15. ISO TC130 WD 12646 p. 5 Section 4.7 Chromaticity and luminance of the white and black points and tracking.

16. ISO 3664:2009, Viewing conditions for graphic technology and photography, p. 9 Uniformity of screen luminance.
17. -
18. ISO 3664:2009. Viewing conditions for graphic technology and photography, p. 10 Monitor luminance.
19. ISO 9241-4 1998 Ergonomic requirement for work with visual display terminals (VDTs) – Part 4: Keyboard requirements. ([ISO 9241-4:1998/Cor 1:2000](#))
20. Barten, P.G.J., (1999) Contrast sensitivity of the human eye and its effects on image quality, SPIE Optical Engineering Press
21. -
22. Barten, P.G.J., (1999) Contrast sensitivity of the human eye and its effects on image quality, SPIE Optical Engineering Press p. 179.
23. Barten, P.G.J., (1999) Contrast sensitivity of the human eye and its effects on image quality, SPIE Optical Engineering Press p. 179 - 181.
24. Kokoschka S. (1986). Visibility aspects of VDUs in terms of contrast and luminance. Behaviour and information technology. vol.5, No. 4, pp 309-333.
25. Schenkman, B., and Kjelldahl, L. (1999). Preferred colour temperature on a colour screen. Displays, 20, 73 - 81.
26. Roberts, A., Eng, B., (1995) "A method for the calculation of tolerances for display primary chromaticity coordinates" Research and development Department, Technical Resources, The British Broadcasting Corporation.
27. www.srgb.com
28. Wyszecki, G., Stiles, W.S., (1982) Colour Science: Concepts and methods, quantitative data and formula, Second Edition, John Wiley & Sons, Inc. Chapter 7, Visual thresholds, pp 567-569.
29. Wyszecki, G., Stiles, W.S., (1982) Colour Science: Concepts and methods, quantitative data and formula, Second Edition, John Wiley & Sons, Inc. Chapter 7, Visual thresholds, pp 574-575.
30. Le Grand, Y. (1957). Light, colour and vision. Chapman and Hall, pp 278-279.
31. Le Grand, Y. (1957). Light, colour and vision. Chapman and Hall.
32. Le Grand, Y. (1957). Light, colour and vision. Chapman and Hall, p. 119
33. Le Grand, Y. (1957). Light, colour and vision. Chapman and Hall, Chapter 11, Luminance difference thresholds, p. 261.
34. Le Grand, Y. (1957). Light, colour and vision. Chapman and Hall, Chapter 11, Luminance difference thresholds.
35. Le Grand, Y. (1957). Light, colour and vision. Chapman and Hall, Chapter 12, Colour difference thresholds p. 279.
36. Fairchild M. D. (1995), "Considering the surround in device-independent colour imaging". www.cis.rit.edu/people/faculty/fairchild/PDFs/Bart.pdf
37. ISO 7779:2010, Acoustics – Measurements of airborne noise emitted by computer and business equipment. This international standard is based on ECMA-74.

38. ISO 3741:2010, Acoustics – Determination of sound power levels of noise sources using sound pressure – Precision methods for reverberation rooms.
39. ISO 3744:2010, Acoustics – Determination of sound power levels of noise sources using sound pressure - Engineering method in an essentially free-field condition over a reflecting plane.
40. ISO 3745:2003, Acoustics – Determination of sound power levels of noise sources – Precision methods for anechoic and semi anechoic rooms.
41. ISO 11201:2010, Acoustics – Noise emitted by machinery and equipment – Measurement of emission sound pressure levels at a work station and other specified positions – Engineering method in an essentially free field over a reflecting plane.
42. ISO 9296:1998, Acoustics – Declared noise emission values of computer and business equipment.
43. Standard ECMA-74 8th edition, Measurement of Airborne Noise Emitted by Information Technology and Telecommunications Equipment.
44. EN 60950-1 (IEC 60950-1). Safety of information technology equipment including business equipment.
45. EMAS EU regulation no 761/2001 concerning the voluntary participation of industrial companies in the Union’s environmental control and review structure.
46. ISO 14001 Environmental management systems - Specification with guidance for use
47. -
48. TCO Certified Own Work questionnaire and assessment guidelines
49. Electronic Industry Citizenship Coalition (EICC), <http://www.eicc.info>
50. SA8000, <http://www.sa-intl.org>
51. www.energystar.gov and
(http://www.energystar.gov/index.cfm?c=partners.pt_index)
52. International Efficiency Marking Protocol for External Power Supplies.
53. EU Directive 2006/66/EC on batteries and accumulators containing certain dangerous substances
54. EU Directive 2002/95/EC on the restriction of the use of certain hazardous substances in electrical and electronic equipment
55. Regulation concerning Registration, Evaluation, Authorisation and Restriction of Chemicals (REACH), EC 1907/2006
56. EU Directive 67/548/EEC on the approximation of laws, regulations and administrative provisions relating to the classification, packaging and labelling of dangerous substances
57. EU Directive EC 1272/2008 on classification, labelling and packaging of substances and mixtures
58. The EU Green Paper “Environmental questions concerning PVC” KOM (2000) 469
59. ISO 11469:2000 Plastics - Generic identification and marking of plastics products
60. ISO 1043-1, -2, -3, -4 Plastics - Symbols and abbreviated terms
61. EU Directive 2002/96/EC on waste electrical and electronic equipment (WEEE)
62. Directive 94/62/EC on packaging and packaging waste.

B Test Methods and clarifications

The following definitions, test conditions, requested specifications from clients, and other information apply to the test methods described in this document.

Test results are valid only for the presentation form(s) and configuration(s) tested.

B.0 General test conditions

B.0.1 Definition of a test object

- Test objects covered by this document are Tablet computers with visual displays with fixed positions of the pixels.
- A test object with all necessary information for its operation shall be delivered to the test laboratory in test ready condition including any required accessories. All necessary information about how to operate and adjust the test object shall be provided.
- The performance of the test object shall in all aspects be fully in accordance with the performance of the final product.
- The client shall inform the test laboratory if any anti-aliasing is used for the Tablet computer. The anti-aliasing can arbitrarily influence the results, causing test laboratories to question the results.

B.0.2 Required test object information

- The client shall specify the name(s), type designation(s) and manufacturer for all different exchangeable parts of the test object.
- The client shall specify the display resolution of the Tablet computer display and the vertical and horizontal frequencies for testing.
- The client shall specify the name, type designation and manufacturer of the graphics card. This information shall be written in the test report.

B.0.3 Conditions for the equipment under test

- The Tablet computer being tested shall be physically prepared for testing and shall be warmed up for at least 30 min or until it is stabilised. The test engineer shall not need to wait for more than 1 hour for the display to be stable. In these cases the engineer may cancel the test and demand a replacement sample
- The Tablet computer screen surface shall be clean when tested.
- The Tablet computer shall be tested under nominal conditions of input voltage, current, etc. If sold on different markets, one setup shall be chosen by the manufacturer which shall represent the conditions of the country in where it will be sold the most.
- The Tablet computer shall be tested with a fully charged battery and be plugged into mains during all tests, unless otherwise specified in the test methods.

- The Tablet computer shall be tested without load on any peripheral interface such as USB, firewire or network hub, memory card slot, loudspeakers or similar unless otherwise stated by the test procedure.

B.0.4 Tablet computer alignment for testing

The Tablet computer display front shall be aligned vertically with the possibility to rotate the display $\pm 30^\circ$ around a vertical axis through the centre-point of the display front. It shall also be possible to rotate the screen forwards and backwards $\pm 30^\circ$ around a horizontal axis through the same centre-point.

B.0.5 Instruments used for testing

All instruments used for testing of a Tablet computer shall be of good quality and validated by a recent test certificate from a certified testing laboratory. Any necessary instrument calibration shall be done before the tests are performed. Calibrations shall be traceable to national standards.

B.0.6 Settings of the Tablet computer

- If present, the standard controls of the Tablet computer shall be used to configure and adjust the display, e.g. brightness, contrast, correlated colour temperature.
- If possible the Tablet resolution shall be set to the native resolution and be used for all test parameters.
- The measurement shall be taken with the Tablet computer in default CCT. If no default CCT is given or available the colour temperature presented by the recall function (or equivalent function) in the OSD (On Screen Display). If no OSD exists the default CCT on start-up shall be used
- All measurements shall be taken with no adjustments made between the measurements, if not otherwise specified in the test methods.
- An external control unit that is not a standard part of the Tablet computer is not allowed.
- The colour depth (6 or 8 bits per colour channel) of the testing program shall be at least as high as for the sample tested.
- The operating system most likely to be used by an end user should be used for testing. All settings in the operating system shall be the default ones as delivered to the end user or the default as it appears directly after the installation of the operating system.
- Integrated automatic sensors and any eco-mode functions enabled by default on the display shall be disabled by the test engineer for all the tests, as long as by doing so the default CCT setting does not change.

B.0.7 Test image/test character

- All test images can be found on the home page of TCO Development, www.tcodevelopment.com.
- A possibility is to use a testing program that shall consist of software commonly used in office and home computer work. The Microsoft word processor should be able to produce the text and graphics required for the test procedures.
- All parts of the tests for a test object shall be conducted using the same font, character size, correlated colour temperature, resolution, operating system and other settings of the Tablet computer controls etc., unless otherwise stated in the test procedure.

B.0.8 Test Image and Test Luminance setting

The test image in Figure B.0.8.1, referred to as the TCO Certified default test image, has an 80 % image loading. The test image shall fill the whole usable screen that represents the “full screen mode” for photo viewing or movies. If a toolbar always consumes a part of the screen during “full screen” photo viewing and movies then the toolbar may also consume a part of the screen during test. This image shall be used for testing unless otherwise specified in the test procedure.

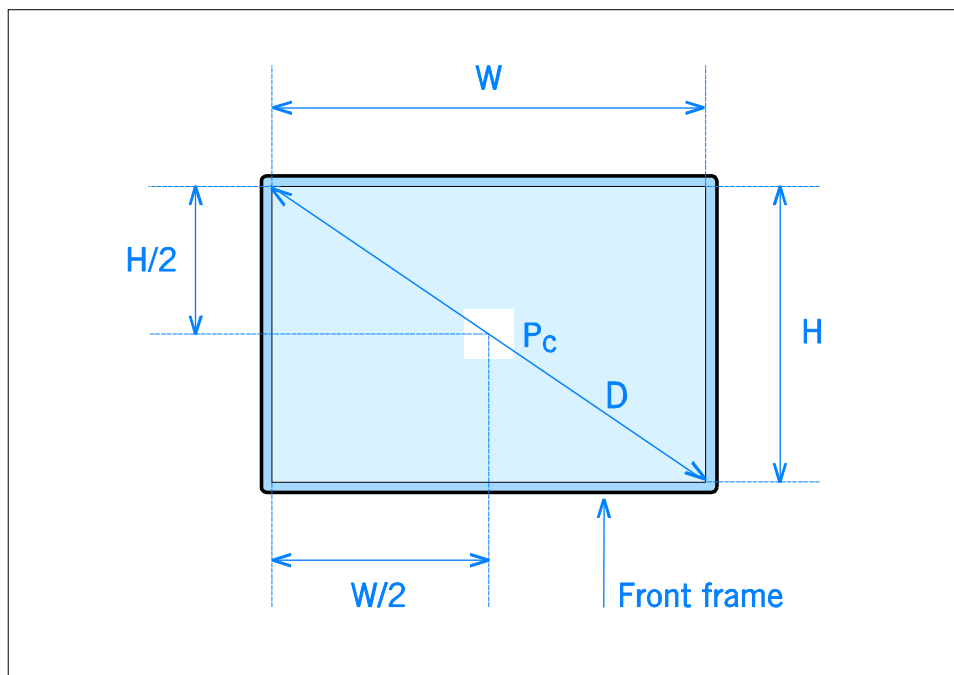

Figure B.0.8.1. The TCO Certified default test image.

Procedure:

- The background colour shall be set to RGB 204, 204, 204 (i.e. equal to 80 % image loading).

- An active white square at the centre of the display shall be $4^\circ \times 4^\circ$ in size and have an RGB setting of 255, 255, 255. The $4^\circ \times 4^\circ$ corresponds to an area of about 34.9 mm x 34.9 mm at a measuring distance of 500 mm or 69.8 mm x 69.8 mm at 1 meter. For a 15" display measured at 57 cm, the $4^\circ \times 4^\circ$ corresponds to a square of 40 mm x 40 mm.

Test Luminance setting:

- The luminance of the Tablet computer shall be adjusted to $\geq 125 \text{ cd/m}^2$. Test luminance shall be as close to, but never $< 125 \text{ cd/m}^2$. To achieve an acceptable image quality proceed as follows:
Use the TCO Certified default test image with an 18-step grey scale pattern (see Figure B.2.2.1) presented on the display at the default CCT setting. The controls of brightness and contrast, if available, shall be adjusted to get the best visual performance of the pattern at the test luminance level. The contrast shall be left at the default setting. The brightness control shall be adjusted to set the display luminance at $\geq 125 \text{ cd/m}^2$. If the possibility of backlight adjustment exists, it shall not be used unless specified by the manufacturer. The aim is to get the 18-step grey scale pattern optimised so that at least 15/18 greyscales are visible at the test luminance level. If greyscale quality is not acceptable it may be improved by changing the contrast setting if available. The evaluation of attaining at least 15 of the steps in the 18-step greyscale shall be carried out orthogonally to the screen surface

B.0.9 Test report

The test results are valid only for the presentation form(s) and configuration(s) tested. If other configurations are accepted by the laboratory based on the results of the tested ones it shall be clearly specified in the test report that these configurations have not been tested.

The test report shall include the following information:

- Any changes to the test methods.
- The manufacturer, brand name, model type and serial number (if available).
- The panel brand, full panel number.
- The mode(s) (i.e. horizontal and vertical scan frequency and resolution) used during the test and the aspect ratio.
- The supply voltage and frequency used during the test and what CLASS the product is (CLASS I, CLASS II or CLASS III). If CLASS III the external power supply brand, model number and class shall also be stated.
- The degree of uncertainty for each given measurement result.
- If present, the setting of contrast, brightness and CCT pre-set used during the test.
- Photographs of the product showing: Front, rear, open panel, a legible panel marking plate and the external power supply with legible marking plate.

B.1 General information

B.1.1 TCO Certified Document

The TCO Certified Document shall accompany the product as provided by TCO Development. No editorial changes without TCO Development's consent are accepted. The Document is available at www.tcodevelopment.com.

If the TCO Certified Document is part of a User's Manual or is provided as an electronic file then it must be separated from other text portions so it is obvious that the Document text is not accountable for the content of the other texts.

The brand name owner may post the TCO Certified Document on its web site, e.g. by showing TCO Certified logos or icons that redirect the visitor by links to the TCO Certified Document

If the product that is to be TCO Certified labelled is branded differently from the applicant name, the applicant company signing the guarantee shall be sure that the brand name holder agrees with the requirement.

B.2 Visual ergonomics

B.2.0 General test conditions for visual ergonomics

B.2.0.1 Basic test requirements

As described in section B.0.

For all tests, the Tablet computer screen shall be clean.

B.2.0.2 Photometric laboratory general requirements

Photometric measurements shall be performed under darkroom conditions. This means that measurement data shall in no way be affected by direct light from sources or light reflected from interiors, equipment, clothes etc.

The laboratory shall have a routine for the control of the stray-light level at the Tablet computer screen (see also B.2.0.6).

B.2.0.3 Power supply and test room climate requirements for testing

- AC mains voltage* 230 VAC RMS, tolerance $\leq 1 \%$
- AC mains frequency* 50 Hz, tolerance $\leq 2 \%$
- Test room temperature $23 \pm 3 \text{ }^\circ\text{C}$
- Humidity 20-75 % RH (non condensing)

* – or other voltage and frequency combination specified by the client.

B.2.0.4 Photometric and spectrometric measurements

Several instruments are to be used when carrying out measurements for visual ergonomics. All instruments shall be recently calibrated and carry a calibration certificate from a certified testing laboratory.

The following instrument types are to be used for testing:

- **Gloss meter.** An instrument for measuring gloss as a function of the directionally selective reflecting properties of a material at angles near to and including the direction giving specular reflection.

- **Luminance meter.** A luminance meter shall have a sufficiently good $V(\lambda)$ -sensitivity (Requirements for luminance meters are covered by CIE Publication 69 (1987). Luminance meters of CIE Class L(aboratory) with a combined performance characteristic $\leq 3\%$ shall be used.) and integrate luminance over a finite measuring field during a finite time. The meter shall be equipped with adjustable optics and always be focused on the measured area. The luminance meter must incorporate a sufficiently long time constant of integration in order to ensure averaging of the pulsation of the light emitted by Tablet computers. The sensitivity shall be independent of the polarization of the measured light (often referred to as f_8 error).

The luminance meter measuring field shall be one degree for all measurements, except for the micro-photometric luminance measurements, see below.

An automated instrument using collimating optics may be used for testing although the measurement area will differ somewhat from the area covered by the luminance meter. When the luminance measurement in this case is done at a shorter distance than $1.5 \times$ the display diagonal (D) because of instrumental constraints, the laboratory shall verify that the results are equal to those done at $1.5 \times D$ or (400mm if $1.5 \times D < 400\text{mm}$).

- **Micro-photometer.** Micro-photometric registration of the luminance distribution of test patterns shall be performed with an array photo detector device capable of resolving structures of 0.02 mm. A scanning device shall not be used because it is sensitive to jitter and other variations that may occur during a scanning.
- **Spectro-radiometer.** An instrument for the measurement of radiant flux as a function of wavelength shall be used. A spectro-radiometer for the measurement of light and colour is normally equipped with a microprocessor that makes it possible to obtain luminance and colour co-ordinates directly from raw measurement data. A spectro-radiometer can replace the luminance meter when suitable. The wavelength resolution shall be $\leq 4\text{nm}$ for attaining accurate colour measurements. The sensitivity shall be independent of the polarization of the measured light (often referred to as f_8 error).

B.2.0.5 Measurement distance

All measurements shall be carried out through a point, simulating the eye position of the operator, at a distance of $1.5 \times$ “diagonal of the screen” from the centre-point of the Tablet screen but no less than 400 mm which could be considered as an absolute minimum viewing distance for comfortable viewing. The instrument shall be focused on the presented test image for all measurements.

B.2.0.6 Stray light

Stray light may cause errors which can negatively affect measurement of luminance, contrast and chromaticity coordinates. It is therefore necessary to make an evaluation of stray light influence for the different measurement procedures described in this document.

If it is verified that stray light affect the measurement result it is necessary to take actions to eliminate the source of error. Two possible ways to solve the problem are to equip the luminance meter with a well-designed screening attachment, a frustum or to use a black screening sheet at the Tablet screen surface.

B.2.0.7 Overall uncertainty

The overall uncertainty of the test laboratory shall be calculated for each measurement procedure in this document and presented in the test report. The uncertainty shall be within the required levels for each criterion. All measurement uncertainties claimed for used instruments shall be referred to traceable calibration reports.

About combining overall uncertainty values during test measurements:

- Criteria are fulfilled without adding or subtracting the overall measurement uncertainty.
- Report the value shown on the instrument without adding or subtracting the overall measurement uncertainty.
- The overall measurement uncertainty of the laboratory is printed in the test report together with the reported value.
- For a Laboratory that has an overall measurement uncertainty higher than the one allowed by TCO Development for a certain criteria, then the test report for that criteria is not valid for TCO certification and the test results will not be accepted by TCO Development.

B.2.1 Image detail characteristics

B.2.1.1 Native display resolution requirements

B.2.1.1.1 Preparation of the Tablet computer for testing

No specific preparation of the Tablet computer is needed.

B.2.1.1.2 Equipment

Calculator and product manual or similar information about the display resolution.

B.2.1.1.3 Test method

The maximum resolution and frequencies of the display are found in the manual or similar information from the manufacturer.

B.2.1.1.4 Test evaluation

The viewing distance is defined as $1.5 \times$ the display diagonal, but no less than 400 mm. This means that the mandate is independent of the display size and viewing distance but dependent on the display format. Only the display format needs to be known.

The minimum resolution to fulfil the criteria can be calculated for any display format in the following way:

Minimum amount of pixels in the vertical direction

Half the display height at the viewing distance expressed in degrees is:

- $\arctan(\text{width}/2/\text{viewing distance})$

The whole display height expressed in degrees is:

- $2 \times \arctan(\text{width}/2/\text{viewing distance})$

The requirement is 30 pixels/degree which gives the amount of pixels needed in the vertical direction to:

- $30 \times 2 \times \arctan(\text{width}/2/\text{viewing distance})$

Example:

For the format 5:4:3 and viewing distance 1.5 this gives the formula:

- $30 \times 2 \times \arctan(4/2/(1.5 \times 5)) = 896 \text{ pixels}$

The principle is the same in the horizontal direction.

For the most common display formats the mandates are:		
<u>Display format</u>	<u>Min amount of horizontal pixels</u>	<u>Min amount of vertical pixels</u>
5:4:3	896	679
18.36:16:9	972	557
6.4:5:4	875	706
18.87:16:10	947	601
Note: Display format is a ratio between [Diagonal : Width : Height]		
For or other aspect ratios the min display resolution shall be calculated.		

B.2.1.1.5 Overall uncertainty

Uncertainty is not applicable in this case. Product data information is sufficient.

B.2.2 Luminance characteristics

B.2.2.1 Luminance level

B.2.2.1.1 Preparation of the Tablet computer for testing

- All necessary preparations described in B.0 and B.2.0 shall be done.
- The TCO Certified default test image with an 18-step greyscale as shown in Figure B.2.2.1 shall be used for luminance level measurement.

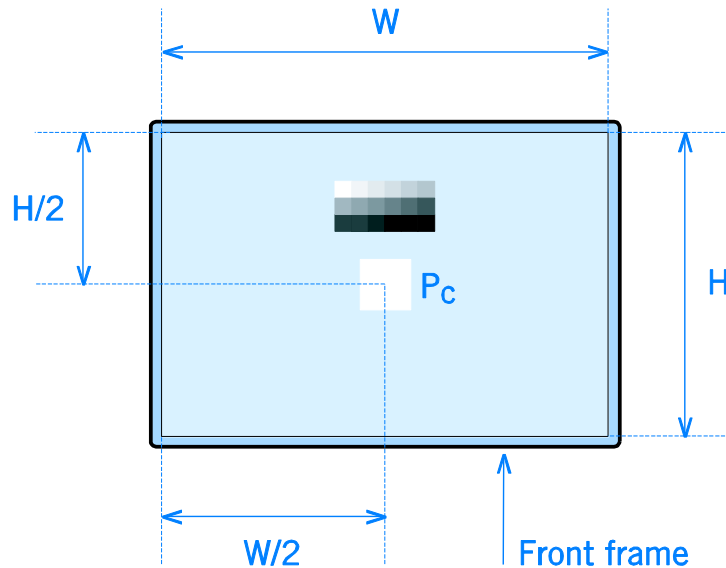

Figure B.2.2.1. TCO Certified default test image with the 18-step greyscale inserted

- The measurement position P_c shall be at the centre of a $4^\circ \times 4^\circ$ square without line borders, having an RGB setting of 255, 255, 255, and positioned at the centre of the screen. The background shall be RGB 204, 204, 204.

The following evaluation shall be carried out orthogonally to the screen surface

- To achieve the maximum luminance proceed as follows:
Use the TCO Certified default test image with an 18-step grey scale pattern presented on the screen. From the default setting, adjust the controls for the display to achieve as high luminance as possible with an acceptable image quality. The image quality is considered acceptable when at least 15 of the 18 greyscale steps are visible. At this maximum luminance, test that the display has a luminance $\geq 200 \text{ cd/m}^2$.
- When this test is completed the display shall be adjusted back to the test luminance setting as describe under B.0.8 for all remaining Visual Ergonomic tests. Allow the display to stabilize before other test measurements are made.

B.2.2.1.2 Equipment

Luminance meter.

B.2.2.1.3 Test method

The luminance at the centre of the white test area shall be measured with the luminance meter directed orthogonally to the test area as described in B.2.0.5. For the battery mode measurement, the battery shall be fully charged. Disconnect the power supply and wait about 5 minutes to have the screen stabilized before the measurement of the luminance is performed. Re-connect the power supply after the Battery mode test is completed.

B.2.2.1.4 Test evaluation

The measured luminance is the required value. The luminance shall be reported with no decimal places.

The measured Luminance, Contrast and Brightness settings shall be noted in the test report. The pre-set CCT in default setting shall also be noted.

B.2.2.1.5 Overall uncertainty

$\leq \pm 10\%$ in luminance.

See B.2.0.7.

B.2.2.2 Luminance uniformity

B.2.2.2.1 Preparation of the Tablet computer for testing

- All necessary preparations described in B.0 and B.2.0 shall be done.
- The entire active area of the screen shall be white and the Tablet computer colour setting shall be RGB 255, 255, 255.

B.2.2.2.2 Equipment:

Luminance meter.

B.2.2.2.3 Test method:

The luminance shall be measured orthogonally to the Tablet screen plane at 9 points. The 4 corner positions (1, 3, 7 and 9) are measured 1° from the edges of the screen as shown in Figure B.2.2.2.1. The 4 side positions (2, 4, 6 and 8) are measured on the middle of the side 1° from the edge. The centre position (5) shall also be measured. This means that all measurement points have $1/2^\circ$ marginal to the edges if the measurement area of the instrument is 1° .

The luminance uniformity shall also be evaluated visually by the technician in order to find any dark or bright areas except from the 9 default positions. If a significantly bright or dark area is found these measuring points shall also be measured and used to evaluate the luminance uniformity.

The conditions for luminance measurement in the corner positions and the distribution of other measurement points are illustrated in figure B.2.2.2.1

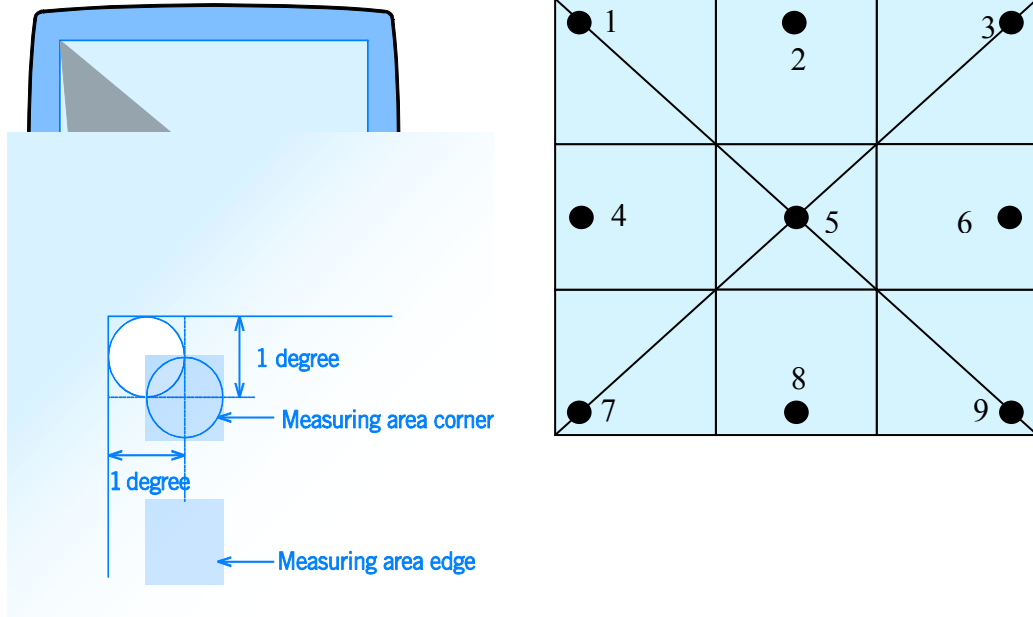

Figure B.2.2.2.1. Measurement positions for the measurement of luminance and colour uniformity.

B.2.2.2.4 Test evaluation

The luminance uniformity shall be reported as the ratio between the highest and the lowest measured luminance values.

The result shall be presented to 2 decimal places.

B.2.2.2.5 Overall uncertainty

$\leq \pm 10\%$ in luminance.

$\leq \pm 0.1$ unit in luminance uniformity.

See B.2.0.7.

B.2.2.3 Luminance uniformity – angular dependence

B.2.2.3.1 Preparation of the Tablet computer for testing

- All necessary preparations described in B.0 and B.2.0 shall be done.
- Luminance values shall be measured at five different positions on the screen as shown in Figure B.2.2.3.1. Each measurement position shall consist of white RGB 255, 255, 255 squares sized $4^\circ \times 4^\circ$ without line borders.
- The background shall be RGB 204, 204, 204.
- The luminance meter shall be positioned and directed orthogonally to the screen centre-point as described in B.2.0.5.

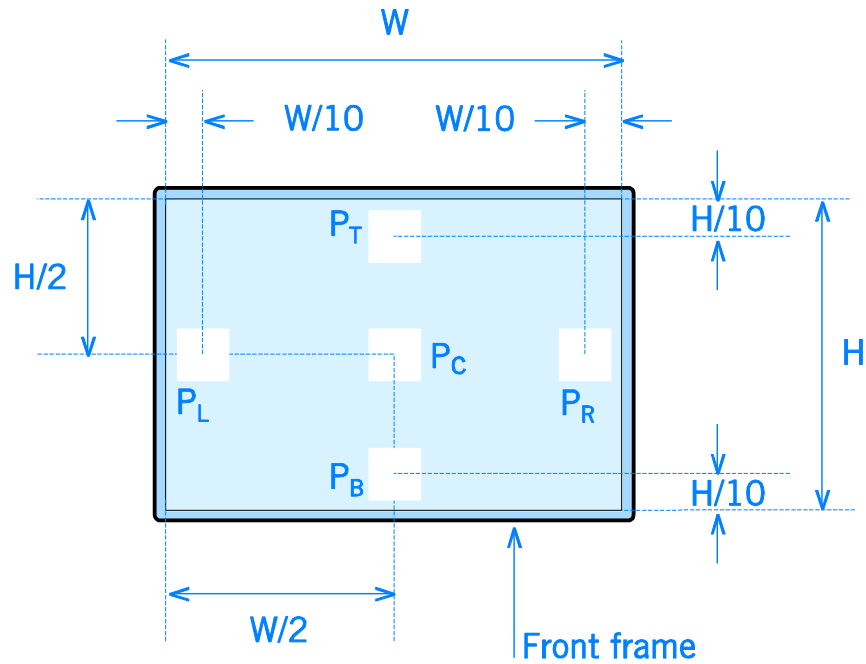

Figure B.2.2.3.1. Measurement positions for angular dependent luminance uniformity.

B.2.2.3.2 Equipment

Luminance meter.

B.2.2.3.3 Test method

1. The luminance meter shall always be directed towards a measurement point and rotated around a fixed vertical axis (or horizontal axis for the tilt measurements) through the focal point of its front lens at the distance described in B.2.0.5.
2. In landscape mode the display shall be rotated +30 degrees around a vertical axis through the display centre-point and the luminance at positions P_L and P_R , ($L_{P_L/+30/0}$ and $L_{P_R/+30/0}$ respectively) shall be recorded. See Figure B.2.2.3.2.
3. In landscape mode the display shall then be rotated -30 degrees around the vertical axis through the screen centre-point and the luminance at positions P_L and P_R ($L_{P_L/-30/0}$ and $L_{P_R/-30/0}$ respectively) shall be recorded. See Figure B.2.2.3.2.
4. In landscape mode the display shall then be tilted +30 degrees backwards around a horizontal axis through the display centre-point and the luminance at positions P_T and P_B ($L_{P_T/0/+30}$ and $L_{P_B/0/+30}$ respectively) shall be measured. The result shall be recorded. See Figure B.2.2.3.3.
5. In landscape mode the display shall then be tilted -30 degrees around a horizontal axis through the display centre-point and the luminance at positions P_T and P_B ($L_{P_T/0/-30}$ and $L_{P_B/0/-30}$ respectively) shall be measured. The result shall be recorded. See Figure B.2.2.3.3.
6. The measurements to be carried out are summarised in Table B.2.2.3.1. The step numbers in the step column are the test method paragraphs

Table B.2.2.3.1.

Steps	Landscape mode	Screen rotation	Screen tilt	Measuring points			
				P _L	P _R	P _T	P _B
Step 2	Horizontal direction (turned around vertical axis)	+30°	0°	X	X		
Step 3	Horizontal direction (turned around vertical axis)	-30°	0°	X	X		
Step 4	Backwards tilt = (turned around the horizontal axis)	0°	+30°			X	X
Step 5	Forwards tilt = (turned around the horizontal axis)	0°	-30°			X	X

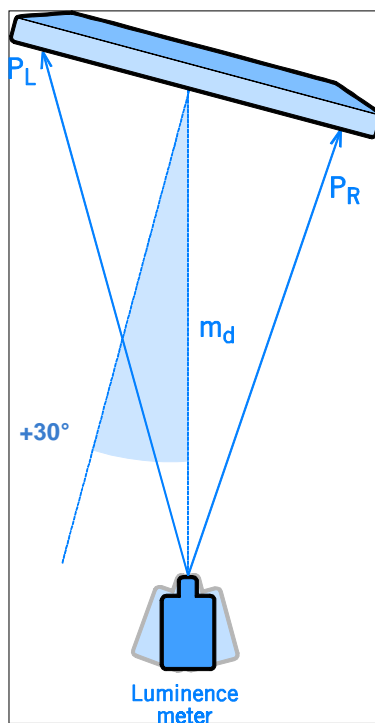

Figure B.2.2.3.2. Top view of test set-up when the display is rotated ± 30 degrees. The + rotation is defined clockwise.

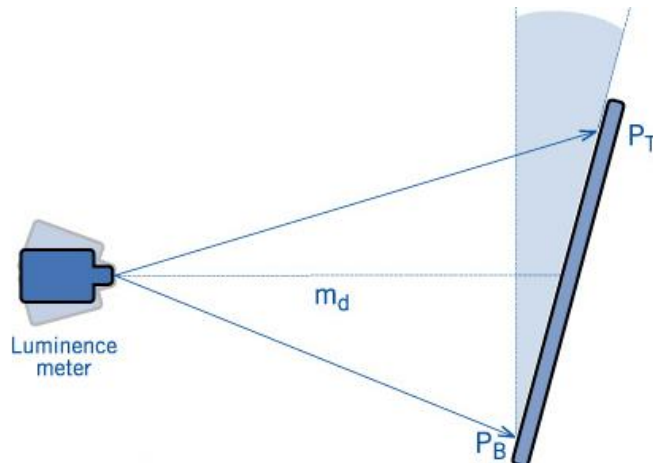

Figure B.2.2.3.3. Side view of the test set-up when the display is tilted +30° backwards. The + tilt is defined backwards.

B.2.2.3.4 Test evaluation

The luminance uniformity for angular dependence shall be calculated as follows:

In landscape mode, for the horizontal direction (turned around the vertical axis) measurement presented in Table B.2.2.3.1 (test step 2 and 3). A ratio between the measured luminances shall be calculated. This ratio, or its inverse if it has a higher value, shall be reported as the requested L_{max} to L_{min} luminance uniformity in **mandate 1**. The requirement is on the mean value of the two ratios +30° and -30°. The result shall be presented to 2 decimal places.

In landscape mode, for the vertical direction (turned around the horizontal axis). Tilt backwards and tilt forwards $\pm 30^\circ$ test steps 4 and 5. A ratio between the two measured luminances shall be calculated. This ratio, or its inverse if it has a higher value, shall be reported as the requested L_{max} to L_{min} luminance uniformity in **mandate 2**. The requirement is on the mean value of the two ratios +30° and -30°. The result shall be presented to 2 decimal places.

Both **mandate 1** and **mandate 2** results shall be presented in the test report.

B.2.2.3.5 Overall uncertainty

$\leq \pm 10\%$ in luminance.

$\leq \pm 0.3^\circ$ in rotation angle.

$\leq \pm 0.1$ unit in luminance uniformity. See B.2.0.7.

B.2.3 Luminance contrast characteristics

B.2.3.1 Luminance contrast – characters

B.2.3.1.1 Preparation of the Tablet computer for testing

- All necessary preparations described in B.0 and B.2.0 shall be done.
- A micro-photometer for luminance measurement shall be aligned orthogonally to the Tablet computer display.
- The test image shall be filled with rows of the regular capital letter “H” in 12 point Arial font.

B.2.3.1.2 Equipment

A micro-luminance meter such as an array photo detector capable of measuring luminance on structures ≤ 0.02 mm. Measurement requirements are given in clause B.2.0.2.

B.2.3.1.3 Test method

- By visual evaluation of the standard test measurement position the technician shall search for and locate visual stripes, or patches, that clearly influence the contrast of characters or even parts of characters. Once the patches are visually identified as having significantly lower contrast they shall be geometrically referenced from the upper left corner of the active image and measured, see below. If one position is found that does not fulfil the mandate, there is no need to make further measurements.
- With a micro-luminance meter or a luminance scanner the luminance signal of and around a vertical stroke of a capital H of 12 point Arial font shall be measured. The optical axis of the luminance meter shall be aligned with the normal of the display surface at the measuring point. The misalignment between the screen surface normal and the optical axis of the luminance meter shall be less than 0.3° .
- The height (h) of the measuring windows shall be $1/3$ of the actual height (H) of the character “H”. The window shall be positioned symmetrically between the horizontal stroke and the lower ending of the vertical stroke (see Figure B.2.3.1.1).

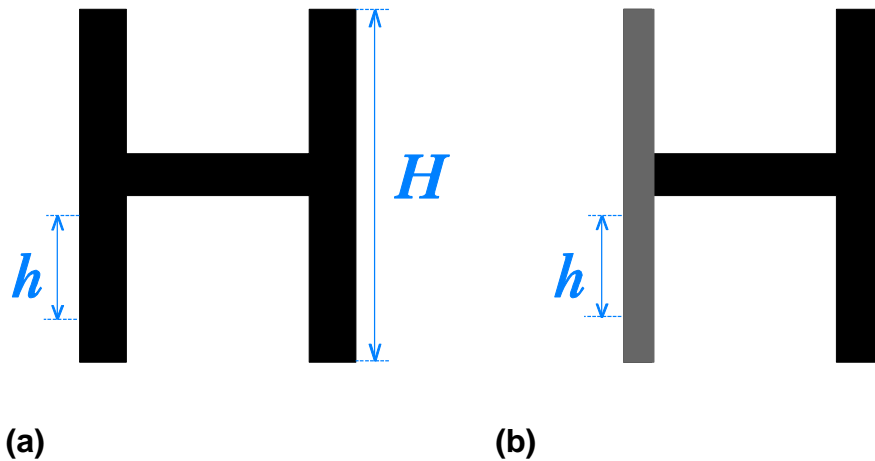

Figure B.2.3.1.1. Example of one capital “H” with (a) good contrast and one with (b) low contrast due to a paler and thinner left vertical stroke. The measuring window having height h shall be positioned symmetrically between the horizontal stroke and the lower ending of the vertical stroke of the H.

- The physical width of each measuring window or the matrix element shall be less or equal to $1/8$ of the pixel size, but not more than 0.02 mm (cf. Figure B.2.3.1.2).

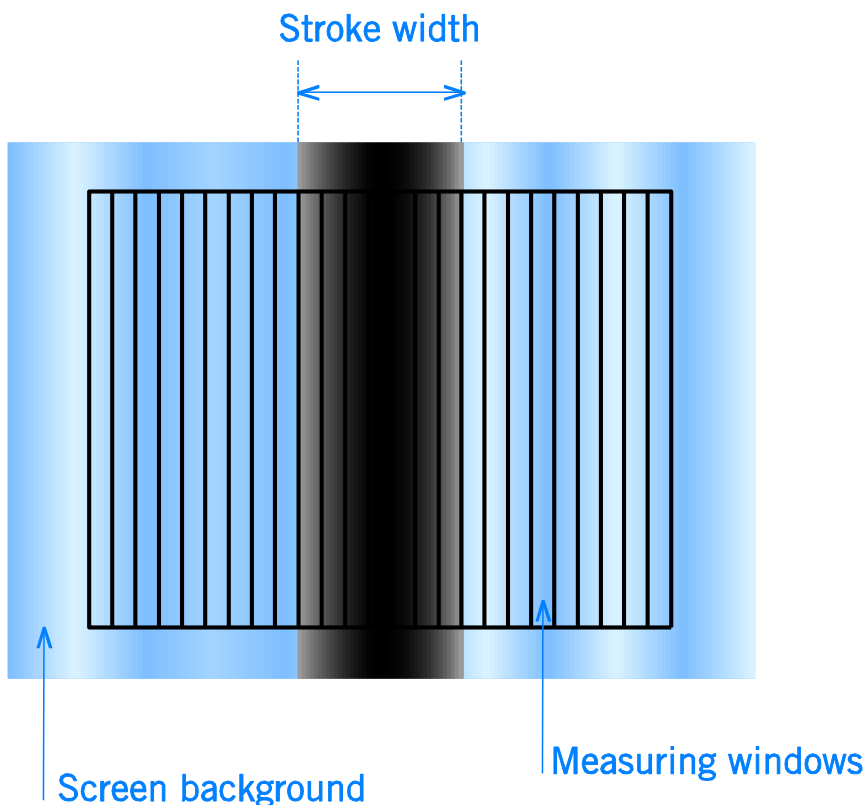

Figure B.2.3.1.2. Magnification of the vertical stroke in Figure B.2.3.1.1(a) showing a number of sampling windows.

- The basic luminance signal scanned from left to right in Figure B.2.3.1.2 could for example be as shown in Figure B.2.3.1.3.

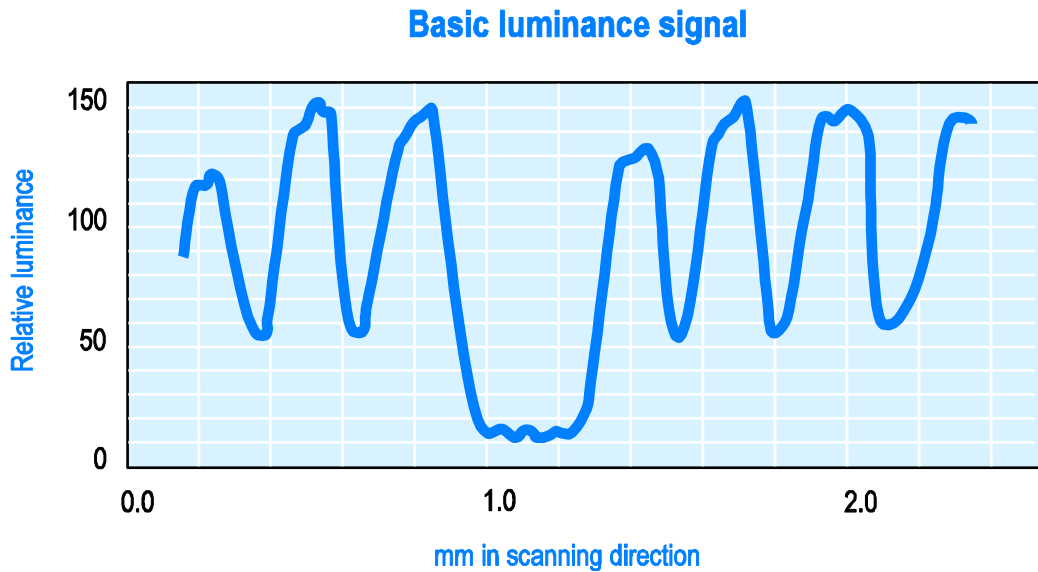

Figure B.2.3.1.3. Example of a basic luminance signal of a vertical stroke of H.

B.2.3.1.4 Test evaluation

- The basic luminance signal received from the micro-luminance meter depends on the resolution (sampling window size) of the sensor and the pixel size of the display. It is likely that the sampling window size differs between laboratories depending on photometer brand.

- The luminance contrast C shall be calculated using the formula

$$C = \frac{L_{\max} - L_{\min}}{L_{\max} + L_{\min}}$$

with the maximum and minimum luminances determined as described below.

- The photometer produces a basic luminance signal, which shall be filtered to a resolution of either 1 or 4 minutes of arc. These filtered signals shall be used for the calculation of C .
- To find L_{\min} proceed as follows: The basic luminance signal shall be filtered to correspond to the 1 minute of arc resolution of the human visual system. This is equal to a sampling window size of 0.145 mm at 500 mm viewing distance. The filtering shall be done by applying a moving average to the basic input data. For example, the 1 minute of arc filtering applied to the luminance signal in Figure B.2.3.1.3 gives the signal in Figure B.2.3.1.4.

1 minute of arc filtered luminance signal used for L_{min} calculation

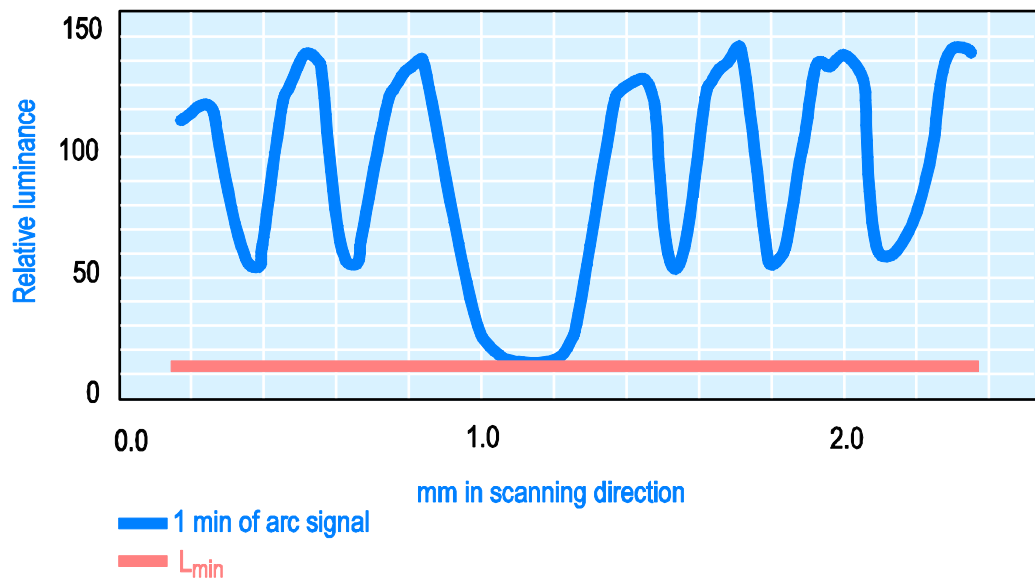

Figure B.2.3.1.4. The luminance signal filtered to 1 minute of arc and showing L_{min} .

- The lowest relative luminance in the vertical stroke in the 1 minute of arc signal is L_{min} . (In the example of Figure B.2.3.1.4, the L_{min} value is 14 cd/m²).
- To find L_{max} proceed as follows: The 4 minute of arc signal filtering shall be obtained by applying a moving average to the 1 minute of arc signal. This corresponds to a more comfortable viewing condition. The filtered luminance signal is shown in Figure B.2.3.1.5.

4 minutes of arc filtered luminance signal used for L_{max} calculation

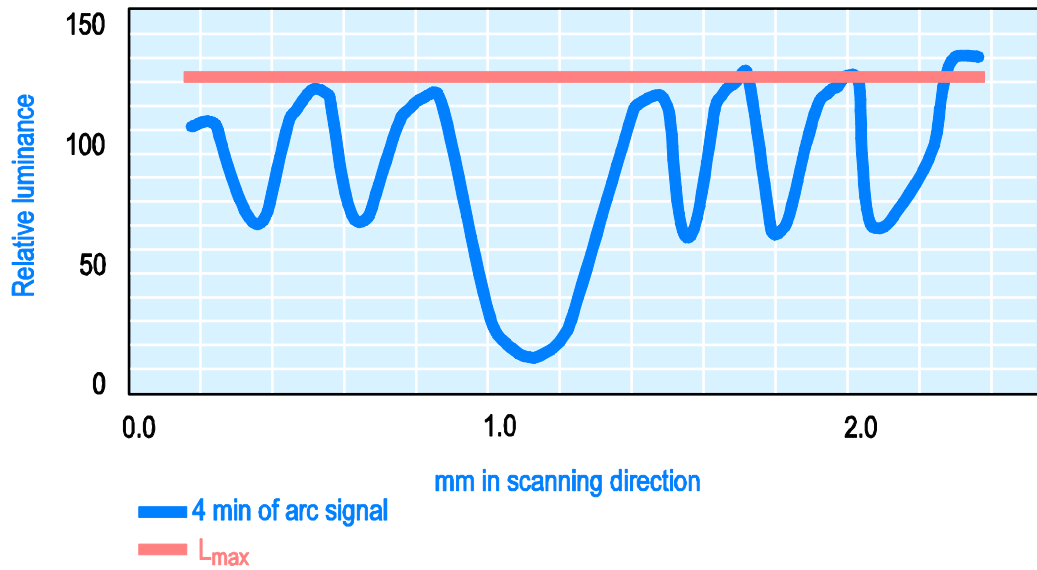

Figure B.2.3.1.5. The 1 minute of arc luminance signal filtered to 4 minutes of arc and showing L_{max} .

- The maximum luminances may be different on the two sides of the H stroke. Select the lower one as L_{max} .

(In the example of Figures B.2.3.1.4 and B.2.3.1.5 the luminance is lower on the left side than the right side and thus

$L_{max} = 127 \text{ cd/m}^2$. With $L_{min} = 14 \text{ cd/m}^2$ the contrast is $C = (127 - 14) / (127 + 14) = 0.80$).

The lowest luminance contrast found shall be reported.

The result shall be presented to 2 decimal places.

- B.2.3.1.5 Overall uncertainty**
 $\leq \pm 0.05$ in contrast.
 See B.2.0.7.

B.2.3.2 Luminance contrast – angular dependence

B.2.3.2.1 Preparation of the Tablet computer for testing

- All necessary preparations described in B.0 and B.2.0 shall be done.
- A TCO default test image, as shown in Figure B.0.8.1, shall be used for this measurement.
- The $4^\circ \times 4^\circ$ square shall have each of the following RGB settings: (RGB 255, 255, 255) and (RGB 0, 0, 0).

B.2.3.2.2 Equipment

Luminance meter.

B.2.3.2.3 Test method

- The luminance meter shall be positioned and directed orthogonally to the screen centre-point as described in B.2.0.5.
- The Tablet computer display shall then be rotated around a vertical axis through the screen front centre, changing the azimuth angle to $+30^\circ$. The luminance of the white square L_{W+30} and the luminance when the square is black L_{B+30} at the centres shall be recorded.
- Finally the azimuth angle of the screen shall be changed to -30° and the new measurements $L_{W/-30}$ and $L_{B/-30}$ taken.

B.2.3.2.4 Test evaluation

The luminance contrast values C_{+30} and C_{-30} shall be calculated using the formula

$$C = \frac{L_W - L_B}{L_W + L_B}$$

Of C_{+30} and C_{-30} , only the lowest value shall be reported as the luminance contrast.

B.2.3.2.5 Overall uncertainty

$\leq \pm 10\%$ in luminance.

$\leq \pm 0.05$ in contrast.

See B.2.0.7.

B.2.4 Reflection characteristics

B.2.4.1 Front frame gloss

B.2.4.1.1 Preparation of the Tablet computer for testing

- No special preparation of the Tablet computer is needed.
- The Tablet frame to be tested shall be clean.
- A gloss measurement instrument needs an absolutely flat surface to function properly.
- If the frame of the Tablet computer is curved, a measurement could be made elsewhere on the housing, provided that the measured surface microstructure, texture and colour are the same as the surface of the front frame.
- If no absolutely flat test surface can be found on the frame surface, then the manufacturer can also supply a flat piece of material with optical properties fully equivalent to the frame material.

B.2.4.1.2 Equipment

A gloss meter in accordance with ISO2813, ASTM D 523 or DIN 67 530 and a calibrated reference standard.

The measurement of gloss shall be made using an instrument with an incident light beam angle of 60° to the normal of the measured surface.

B.2.4.1.3 Test method

Measurement of gloss shall be made at several locations on the Tablet frame which is in the line of sight of the user. Logos, brand names, type marks, control buttons, cameras and other small markings are excluded from the measurements and the requirements.

B.2.4.1.4 Test evaluation

The gloss results shall be presented in gloss units with no decimal places.

The highest recorded gloss value shall be reported.

B.2.4.1.5 Overall uncertainty

$\leq \pm 2$ gloss units. See B.2.0.7

B.2.5 Screen colour characteristics

B.2.5.1 Correlated colour temperature (CCT) variation

B.2.5.1.1 Preparation of the Tablet computer for testing

- All necessary preparations described in B.0 and B.2.0 shall be done.
- A TCO Certified default test image, as shown in Figure B.0.8.1, shall be used for this measurement.

B.2.5.1.2 Equipment

Spectro-radiometer capable of presenting CIE u' and v' chromaticity co-ordinates with at least three decimals.

B.2.5.1.3 Test method

The spectral properties at the centre of the test square shall be measured with a spectro-radiometer.

The spectral data shall then be processed, which is normally done directly in the instrument microprocessor, to give chromaticity co-ordinates. In this case the CIE co-ordinates u' and v' are needed for the test evaluation and are often presented directly by the spectro-radiometer used.

If the client has stated more than two pre-set CCTs, preparation and testing shall be repeated for the additional CCTs.

The following rules shall apply:

- Recommended default CCTs is 6500 K, but the CCT can be anywhere between 5000K and 10000K.
- Only CCTs with exactly specified numerical values have to fulfil the requirements for Pre-set CCTs.
- CCTs lower than 5000 K shall not be tested.

B.2.5.1.4 Test evaluation

The measured u'_m and v'_m values of the screen for the pre-set CCT and the CIE reference chromaticity co-ordinates u'_{CCT} and v'_{CCT} values for the reported CCT shall be used to calculate the colour difference as follows:

$$\Delta u'v' = \sqrt{(u'_{CCT} - u'_m)^2 + (v'_{CCT} - v'_m)^2}$$

This calculation shall be done for all tested pre-set CCTs.

The CIE 1976 u' and v' reference chromaticity co-ordinates for five common CCTs are given in Table B.2.5.1.1.

Table B.2.5.1.1

CCT in K	u'_{cct}	v'_{cct}
9300	0.1888	0.4457
7500	0.1935	0.4586
6500 (sRGB)	0.1978	0.4684
5500	0.2044	0.4808
5000	0.2091	0.4882

If preset CCTs, other than those given in Table B.2.5.1.1, are used in the test, u'_{CCT} and v'_{CCT} can be found by using CIE tabulated data or by using CIE formulae presented in CIE Publication 15.2 (1986), Colourimetry, p.11, p. 27-28 and p. 53-54, Table 1.3.

If the spectro-radiometer used can only produce CIE 1931 x and y chromaticity co-ordinates these can be transformed to u' and v' chromaticity co-ordinates by using the formulae in the CIE Publication 15.2 mentioned above.

The relevant CIE material – conversion formulae and tabulated data for u'_{CCT} and v'_{CCT} – can also be found on the TCO Development homepage, www.tcodevelopment.com. A computer program based on the given equations can be supplied by TCO Development.

The resulting colour difference calculation shall be presented to 3 decimal places. If the Tablet has no Pre-set CCTs then the measured default colour temperature to be stated in the report shall be given in Kelvin (K).

- B.2.5.1.5 Overall uncertainty**
 $\leq \pm 0.003$ in u' and v' .
 See B.2.0.7.

B.2.5.2 Colour uniformity

B.2.5.2.1 Preparation of the Tablet computer for testing

- All necessary preparations described in B.0 and B.2.0 shall be done.
- The entire active area of the screen shall be white with the Tablet computer's colour setting at RGB 255, 255, 255.

B.2.5.2.2 Equipment

Spectro-radiometer with a capacity to present u' and v' co-ordinates with at least 3 decimals.

B.2.5.2.3 Test method

The colour uniformity shall be measured orthogonally to the Tablet computer screen plane at 9 points. The 4 corner positions (1, 3, 7 and 9) are measured 1° from the edges of the screen as shown in Figure B.2.2.2.1. The 4 side positions (2, 4, 6 and 8) are measured on the middle of the side 1° from the edge. Finally the centre position (5) is measured.

The colour uniformity shall also be evaluated visually by the technician in order to find those areas where the colour varies the most except from the 9 default positions. If a significant difference within the 1° from the edge screen area is found these measuring points shall also be measured and used to evaluate the colour uniformity.

The conditions for colour measurement in the corner positions and the distribution of other measurement points are illustrated in Figure B.2.2.2.1.

B.2.5.2.4 Test evaluation

$\Delta u'v'$ in accordance with the CIE (1976) uniform chromaticity scale diagram shall be calculated for each measured position using the formula

$$\Delta u'v' = \sqrt{(u'_A - u'_B)^2 + (v'_A - v'_B)^2}$$

where A and B are the two points found to have the largest colour difference between them.

The largest difference in $\Delta u'v'$ value shall be reported.

The result shall be presented to 3 decimal places.

(The evaluation procedure is exemplified below)

- Make a table of colour chromaticity values for each measured position

Measurement position no.	u'	v'
1	0.190	0.447
2	0.186	0.441
3	0.186	0.437
-	-	-
-	-	-
n-1	0.185	0.434
N	0.186	0.432
Largest difference	0.005 in this example	0.015 in this example

- The largest u' difference, $\Delta u'$, is 0.005 (between 0.190 and 0.185) at measurement positions 1 and n-1.
- The largest v' difference, $\Delta v'$, is 0.015 (between 0.447 and 0.432) at measurement positions 1 and n.
- Since $\Delta v'$ (= 0.015) is much larger than $\Delta u'$ (= 0.005), the $\Delta v'$ value shall be used for the calculation of $\Delta u'v'$.
- The corresponding two pairs of u' and v' to be used for the calculation are thus the values found at position 1 and position n and thus become the values used for points A and B such that

$$u'_1 = u'_A = 0.190 \text{ and } v'_1 = v'_A = 0.447 \text{ for point A in this example}$$

and

$$u'_n = u'_B = 0.186 \text{ and } v'_n = v'_B = 0.432 \text{ for point B in this example}$$

Hence $\Delta u'v' = \sqrt{0.000016 + 0.000225} = 0.01552$, which shall be reported as 0.016.)

B.2.5.2.5 Overall uncertainty

$\leq \pm 0.003$ in u' and v' .

See B.2.0.7.

B.2.5.3 RGB settings

B.2.5.3.1 Preparation of the Tablet computer for testing

- All necessary preparations described in B.0 and B.2.0 shall be done.
- A TCO Certified default test image, as shown in Figure B.0.8.1, shall be used for this measurement.
- The $4^\circ \times 4^\circ$ squares shall have each of the following RGB settings:
(255, 0, 0) for red,
(0, 255, 0) for green,
(0, 0, 255) for blue.

B.2.5.3.2 Equipment

Spectro-radiometer with a capacity to present u' and v' co-ordinates with at least 3 decimals.

B.2.5.3.3 Test method

The instrument shall be directed orthogonally towards the different test square centres at the measurement distance described in B.2.0.5. Measure the chromaticity co-ordinates at the centre of the $4^\circ \times 4^\circ$ square for each colour setting specified above. Change the colour of the square for each measurement.

B.2.5.3.4 Test evaluation

The recorded chromaticity co-ordinates u' and v' for the red, green and blue squares shall be reported.

The u' and v' shall be presented to 3 decimal places.

B.2.5.3.5 Overall uncertainty

$\leq \pm 0.003$ in u' and v' for red and green.

$\leq \pm 0.007$ in u' and v' for blue.

See B.2.0.7.

B.2.5.4 Colour uniformity – angular dependence

B.2.5.4.1 Preparation of the Tablet computer for testing

- All necessary preparations described in B.0 and B.2.0 shall be done.
- The screen background shall be RGB 204, 204, 204.
- Chromaticity co-ordinates u' and v' shall be measured at three different positions on the screen as shown in Figure B.2.5.4.1. Each measurement position shall consist of white RGB 255, 255, 255 squares sized $4^\circ \times 4^\circ$.
- The spectro-radiometer shall be positioned and directed orthogonally to the display centre-point as described in B.2.0.5.

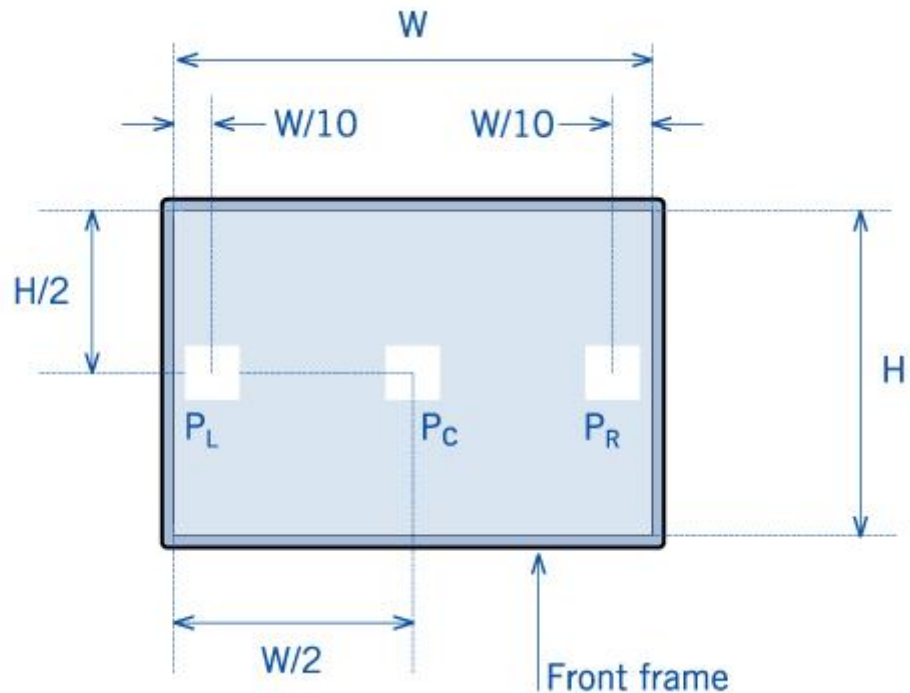

Figure B.2.5.4.1. Measurement positions for colour uniformity-angular dependence.

B.2.5.4.2 Equipment

Spectro-radiometer with a capacity to present u' and v' co-ordinates with at least 3 decimals.

B.2.5.4.3 Test method

- The spectro-radiometer shall always be directed towards a measurement point and rotated around a fixed vertical axis, (or horizontal axis for the tilt measurement) through the focal point of the front lens with a distance as described in B.2.0.5.
- The spectro-radiometer shall be turned towards positions P_C , P_L and P_R and focused. The colour co-ordinates at positions P_L and P_R ($u'_{PL/0}$, $v'_{PL/0}$ and $u'_{PR/0}$, $v'_{PR/0}$ respectively) shall be recorded.
- The screen shall then be rotated $+30^\circ$ around a vertical axis through the screen centre-point and the chromaticity co-ordinates at positions P_L , P_R , ($u'_{PL/+30}$, $v'_{PL/+30}$ and $u'_{PR/+30}$, $v'_{PR/+30}$ respectively) shall be recorded.
- The screen shall finally be rotated -30° around a vertical axis through the screen centre-point and the chromaticity co-ordinates at positions P_L , P_R , ($u'_{PL/-30}$, $v'_{PL/-30}$ and $u'_{PR/-30}$, $v'_{PR/-30}$ respectively) shall be recorded.

B.2.5.4.4 Test evaluation

$\Delta u'v'$ in accordance with the CIE (1976) uniform chromaticity scale diagram shall be calculated for each measured position using the formula

$$\Delta u'v' = \sqrt{(u'_A - u'_B)^2 + (v'_A - v'_B)^2}$$

where A and B are the two points found to have the largest colour difference between them.

The largest difference in $\Delta u'v'$ value shall be reported

The result shall be presented to 3 decimal places.

(The evaluation procedure is exemplified below)

- Make a table of chromaticity values for each measurement position and calculate $\Delta u'v'$ for +30° for and -30°

Measurement position no.	Example value u'	Example value v'
PL /+30	0.190	0.447
PR /+30	0.187	0.442
Difference at +30°	0.003	0.005
$\Delta u' v'$ at +30°	0.0059	
Measurement position no.	Example value u'	Example value v'
PL /-30	0.182	0.436
PR /-30	0.189	0.432
Difference at -30°	0.007	0.004
$\Delta u' v'$ at -30°	0.0081	
Largest difference $\Delta u' v'$	0.0081 in this example	

- The largest calculated $\Delta u'v'$ difference is 0.0081 when the display is rotated -30°. The test value to be reported is this value, reported to 3 decimal places, thus 0.008.

B.2.5.4.5 Overall uncertainty

$\leq \pm 10\%$ in luminance.

$\leq \pm 0.003$ units for u' and v' .

$\leq \pm 0.3^\circ$ in rotation angle.

See B.2.0.7.

B.2.5.5 Colour greyscale linearity

B.2.5.5.1 Preparation of the Tablet computer for testing

- All necessary preparations described in B.0 and B.2.0 shall be done.
- A TCO Certified default test image, as shown in Figure B.0.9.1, shall be used for this measurement.
- The 4° × 4° square shall have each of the following RGB settings: R=G=B= 255, 225, 195, 165, 135, 105

B.2.5.5.2 Equipment

Spectro-radiometer with a capacity to present u' and v' co-ordinates with at least 3 decimals.

B.2.5.5.3 Test method

The instrument shall be directed orthogonally towards the different test square centres at the measurement distance described in B.2.0.5. Measure the chromaticity co-ordinates at the centre of the 4° × 4° square for each greyscale step specified above. Change the greyscale of the square for each measurement.

B.2.5.5.4 Test evaluation

The evaluation task is to find the two grey scale steps that represent the pairs of u' and v' giving the largest colour difference in Δu'v' by use of the equation:

$$\Delta u'v' = \sqrt{(u'_A - u'_B)^2 + (v'_A - v'_B)^2}$$

Where indices A and B are the two grey levels found to have the largest colour difference between them.

The largest difference in Δu'v' value shall be reported.

The result shall be presented to 3 decimal places.

The evaluation procedure is exemplified below

Make a table of chromaticity values for each grey level.

Example value			
Grey level	Luminance cd/m ²	u'	v'
255	124.8	0.190	0.447
225	90.4	0.186	0.441
195	61.2	0.186	0.437
165	40.1	0.185	0.435
135	25.2	0.185	0.434
105	15.8	0.186	0.432
Maximum difference		0.005 in this example	0.015 in this example

- The largest u' difference, Δu', is 0.005 (between 0.190 and 0.185 at grey levels 255 and 165/135 respectively).

The largest v' difference, Δv', is 0.015 (between 0.447 and 0.432 at grey levels 255 and 105 respectively).

- Since $\Delta v'$, (= 0.015) is much larger than $\Delta u'$ (= 0.005), the $\Delta v'$ value shall be used for the calculation of $\Delta u'v'$.
- The corresponding two pairs of u' and v' to be used for the calculation are thus the values found at grey level 255 and grey level 105 and thus

$u'_{255} = u'_A = 0.190$ and $v'_{255} = v'_A = 0.447$ for grey level A in this example

$u'_{105} = u'_B = 0.186$ and $v'_{105} = v'_B = 0.432$ for grey level B in this example

Hence $\Delta u'v' = \sqrt{0.000016 + 0.000225} = 0.01552$, which shall be reported as 0.016).

B.2.5.5.5 Overall uncertainty

$\leq \pm 10\%$ in luminance.

$\leq \pm 0.003$ units for u' and v' .

See B.2.0.7.

B.4 Emissions

B.4.1 Acoustic noise

The acoustic noise test shall only be carried out if the Tablet has integrated moving mechanical parts

B.4.1.1 Method

Prior to testing, the computer shall have been switched on for 15 minutes. Switch on the computer and begin recording elapsed time, starting either when the computer is initially switched on, or immediately after completing any log in activity necessary to fully boot the system. Once logged in with the operating system fully loaded and ready, close any open windows so that the standard operational desktop screen or equivalent ready screen is displayed. Exactly 15 minutes after the initial boot or log in, start to accumulate test noise levels.

The noise measurements shall follow ISO 7779:2010 and shall be declared according to ISO 9296:1988. (However the principle for how the measurement uncertainty is handled shall be the same as for all the other criteria in this TCO Certification. This means that no uncertainty shall be added to the result presented in the report.)

In addition to reporting the measured *A-weighted sound power level* (L_{WA}) in Bels (B) the single measurement values of the 9 measurement positions and the mean value of these *A-weighted sound pressure level* (L_{pA}) in Decibels (dB) have to be included in the test report.

B.4.1.2 Overall uncertainty

The test shall be performed in such a way that the total extended uncertainty in the test result will be less than $\pm 2.5\text{dB}$.

Note

The uncertainties given are worst case limits. In many cases it will be possible to obtain better accuracy.

B.6 Environmental requirements

B.6.0 General Clarification

B.6.0.1 Signatures

The templates in the ecological declaration shall be sent either with original signatures or as copies of original documents with original signatures. “Copies” are for example telefaxes or pdf-files of scanned signed documents. TCO Development and/or the responsible laboratory may later request the original signed document.

However, copies will not be accepted where the signature has been scanned and pasted into the document.

TCO accepts digital signature as an alternative to traditional signature on test reports and declarations submitted as pdf files. To approve a digital signature it is necessary to also submit a digital key to the eco-verifier to facilitate identification.

B.6.1 Product description

The A.6.1 template shall be completed with the requested information about the Tablet. This includes the display, panel and external power supply.

The type key that includes an Asterisk (*) for unidentified characters, if any, in the model name and panel identification name shall be submitted to the eco-verifier. Only two * may be used in the model type key and each * must include two or more options. For the most up-to-date information about type keys, see the appropriate product Application Process at www.tcodevelopment.com

B.6.2 Organisation

B.6.2.1 Environmental management system certification

The certificate shall be issued by a certification body that is accredited by an accreditation body covered by the International Accreditation Forum, www.iaf.nu, Multilateral Arrangement on Environmental Management Systems.

For applicants submitting several applications, it is enough to attach an ISO 14001 certificate or EMAS registration with the first application.

The certificate or an appendix to the certificate shall show the scope of the certification.

B.6.3 Climate

B.6.3.1 Energy consumption – external power supply

TCO Development has decided that energy consumption of the external power supply shall follow the U.S. Environmental Protection Agency's (EPA) demands for compliance with The International Efficiency Protocol requirement for level V, equivalent to the Energy Star version 2.0 for external power supplies, also covering battery chargers.

The international efficiency mark consists of a Roman numeral (I – VI) that corresponds to specific minimum Active and No-Load efficiency levels (as well as a power factor requirement for level V) and is printed/applied by the manufacturer on the external power supply marking plate.

A TCO Development laboratory will require to see a copy of the Tablet's external power supply marking plate there The International Efficiency Protocol requirement for level V symbol is visible as proof of compliance.

B.6.4 Environmentally hazardous substances

B.6.4.1 Mercury (Hg) free

The TCO Development mandate includes FPD lamps which are exempted in RoHs. The maximum concentration value for mercury is 0.1% by weight in homogeneous materials, in accordance with EU Directive 2002/95/EC (RoHS). The maximum concentration value for batteries is 0.0005% of mercury per listed part according to EU Directive 2006/66/EC.

B.6.4.2 Cadmium (Cd), lead (Pb) and hexavalent chromium (CrVI)

Exemptions for cadmium, lead and hexavalent chromium are according to EU Directive 2002/95/EC (RoHS) and the documents supporting the directive.

The maximum concentration values tolerated by weight in homogeneous materials for cadmium, mercury, lead and hexavalent chromium are according to EU Directive 2011/65/EU (RoHS) and the documents supporting the directive.

The maximum concentration value for batteries is 0,002 % for cadmium per listed part, according to EU Directive 2006/66/EC.

TCO Development supports the use of recycled plastic. To avoid making it more difficult to use recycled plastic, exceptions to this requirement can be accepted. If recycled plastic is used in the product please contact TCO Development for further instructions.

B.6.4.3 Halogenated substances

Mandate 1 applies to plastic components weighing more than 25 g shall not contain flame retardants or plasticizers that contain organically bound chlorine or bromine. LCD panels are included in the requirement. Exempted are printed wiring board laminates, electronic components and all kinds of cable insulation.

Mandate 2 applies to the whole Notebook computer. Printed Wiring Boards are also included in the requirement.

HBCDD has been identified as a Substance of Very High Concern in accordance with EU REACH criteria. The main application of HBCDD in EEE is as a flame retardant in HIPS plastic being used for closures and structural parts of different types of EEE. TCO Development considers that the use of HBCDD in EEE is not deemed essential as technically suitable alternative substances and materials are available and already used extensively today.

Maximum concentration values tolerated for a restricted substance (including decaBDE) is 0.1 % by weight in homogeneous materials.

TCO Development supports the use of recycled plastic. To avoid making it more difficult to use recycled plastic, exceptions to this requirement can be accepted. If recycled plastic is used in the product please contact TCO Development for further instructions.

B.6.4.4 Non-halogenated substances

Classification, Labelling and Packaging of Substances and Mixtures, known as the CLP Regulation, EC 1272/2008 came into force January 2009. The new regulation will eventually replace the Dangerous Substances Directive 67/548/EEC and Dangerous Preparations Directive 1999/45/EC. The transitional dates from which substance classification & labelling must be consistent with the new rules is 1 December 2010 (2012 if the substance is already on the shelves) and 1 June 2015 (2017) for mixtures (preparations).

Maximum concentration values tolerated for a restricted substance is 0.1 % by weight in homogeneous materials.

TCO Development supports the use of recycled plastic. To avoid making it more difficult to use recycled plastic, exceptions to this requirement can be accepted. If recycled plastic is used in the product please contact TCO Development for further instructions.

It takes time for the industry to phase hazardous substances out of productions. To give some preparation for that, the following list of substances are planned to be restricted in the next version of TCO Certified (*estimated publication Q1 2014*). *The complete table with references and further information can be provided by TCO Development upon request.*

Likely banned substances in the next version TCO Certified		
English name	CAS	Hazard statements
Antimony(III) oxide (Sb ₂ O ₃)	1309-64-4	H351
Tri-o-cresyl phosphate	78-30-8	H411, H370
Triethyl phosphate	78-40-0	H341, H350, H302, H319
Magnesium hydroxide	1309-42-8	H372, H315, H319, H335, H302, H332, H318,
	138265-88-0	H410, H400
Zinc borates (2ZnO.3B ₂ O ₃)	12767-90-7	H410, H400, H319
Triphenyl phosphate (TPP)	115-86-6	H411, H400, H410, H413, H319
Sodium toluene-4-sulphonate	657-84-1	H341, H351, H400, H301, H312, H317, H319, H332, H315, H335, H302, H318
Bis phenolA bis (biphenyl) phosphate (BDP)	181028-79-5	Technical grade contains TPP
(1-methylethylidene)di-4,1-phenylenetetraphenyl diphosphate	5945-33-5	Constituent of BDP, Technical grade contains TPP
Tri-cresyl phosphate	1330-78-5	H411, H400, H410, H413, H319, H317, H361, H373, H312, H302, H370
Cresyl diphenyl phosphate	26444-49-5	H410, H400, H302
Resorcinol bis (diphenyl diphosphate) (RDP)	57583-54-7	H411, H412

B.6.4.5 Plastics with chlorine and bromine as part of the polymer

TCO Development supports the use of recycled plastic. To avoid making it more difficult to use recycled plastic, exceptions to this requirement can be accepted. If recycled plastic is used in the product please contact TCO Development for further instructions.

B.6.4.6 Information regarding plastics and flame retarding agents

PWB laminates contained in LCD panels shall be listed if the conditions set out by the mandate are met.

B.6.5 Product lifetime

B.6.5.1 Warranty and spare parts

That spare parts shall be available for three years from “the time that production ceases” is only applicable to the production of the specific Tablet, certified by the brand owner.

Regarding spare parts:

1. If a part of a product is broken (e.g. bezel, stand) the end user shall not need to replace the whole product, only the broken part. The broken part shall be possible to replace with an equivalent part (this part does not have to be identical to the broken part).
2. When the cost for replacing a broken part (e.g. panel) exceeds the cost of replacing the whole product, then that part need not be considered as a spare part under this mandate.

B.6.6 Preparation for Recycling

B.6.6.1 Material coding of plastics

If the amount of flame retardant exceeds 1 % by weight the coding shall be complemented in accordance with ISO 1043-4.

The requirements also apply to plastics in the LCD panel, however labelling of the light guide may instead consist of the application of a label in close proximity, for example PLASTIC LIGHT GUIDE:>*plastic type(s)*< or >PLASTIC LIGHT GUIDE:*plastic type(s)*<. Labelling of Plate diffuser (not thin plastic film diffuser) shall follow the same rules as for the light guide.

The requirement does not cover other thin plastic films in the panel due to difficulties in labelling these.

B.6.6.2 Variety of plastics

Clarification: A different additive marking will not make the plastic a different plastic type. For example ABS with FR40 and ABS with FR50 is considered *one* plastic type (two are still allowed).

B.6.6.3 Take back system

Tick the box of the option chosen.

If the applicant chooses **option 1** (*Product only sold on markets with WEEE legislation or similar*) and signs the declaration, the requirement is fulfilled.

If **option 2 or 3** (*World-wide product take back or One additional market lacking WEEE legislation where product take back is offered*) is chosen, the declaration must be signed and the applicant must provide a short description of how the take-back system on that market works. This can also be done by giving a reference (for example a link to a website) to the representative, associated company or affiliate taking care of the take-back system on that market.

In case of option 3 the applicant must also provide the name of the market (country) where a take back system is provided.

TCO Development has no requirement on the take-back system being free of charge.

It is important to point out that any recycling and waste export control legislation in countries where the applicant company operates must always be met.

B.6.7 Product packaging

B.6.7.1 Hazardous substances in product packaging

Limit values are according to Directive 94/62/EC on packaging and packaging waste.

B.7 Corporate Social Responsibility

B.7.1.1 General Clarifications

TCO Development is from this version of the criteria taking the next step in relation to Corporate Social Responsibility (CSR) by introducing an extended mandate regarding supply chain responsibility, since the way in which products are produced is gaining importance for consumers as well as professional buyers. Within the ICT industry supply chain responsibility is increasingly seen as a hygiene determinant.

We aim to be a sustainability label that assures good products in three relevant areas – environmental, social and ergonomics. We want the label to be proof for compliance with public procurement ethical criteria as well as with private sector CSR policies.

The Social performance criteria are based on the eight ILO core conventions and local legislation. This stipulates minimum standards as for the situation in the production facilities. ILO (International Labour Organization) is a United Nations specialized agency with the aim to promote social justice and humane working conditions. The organization consists of representatives of national states, corporations and labour unions.

It is also important the Brand owner has an appointed senior management representative who, irrespective of other responsibilities, ensures that the requirements of this mandate are met. The contact details of this person shall be submitted and shall be available for dialogue in English with TCO Development throughout the certification period. This aims to create an open and transparent dialogue between TCO Development and the brand owner company.

B.7.1.1.1 Electronic Industry Citizenship Coalition (EICC)

The Electronic Industry Citizenship Coalition (EICC) is a group of companies working together to create a comprehensive set of tools and methods that support credible implementation of the Electronic Industry Code of Conduct throughout the Electronics and Information and Communications Technology (ICT) supply chain.

The Electronic Industry Code of Conduct is a code of best practices adopted and implemented by some of the world's major electronics brands and their suppliers. The goal is to improve conditions in the electronics supply chain. Development of the Code was a multi-stakeholder effort, influenced by internationally-recognized standards. By consolidating and standardizing compliance, audit and reporting efforts, suppliers can focus on achieving the high standards of performance set forth by the Code. This approach is also conducive to fostering a culture of social responsibility throughout the global electronics supply chain. EICC sets forth performance, compliance, auditing and reporting guidelines across five areas of social responsibility:

- Labour
- Health and Safety
- Environmental
- Management System
- Ethics

As documented proof we require:

1. An EICC membership document
2. An annual list (that is not older than 12 months) of all third party audits of compliance with the EICC code of conduct, conducted at the first tier production facilities of TCO certified products.
3. One full report of a third party audit (that is not older than 12 months) conducted at a first tier production facility of TCO certified products.

If the brand owner cannot present a full report that has been conducted during the last 12 months, then a final option is to buy one audit (for a subsidized fee) from a third party appointed by TCO Development.

More information:

<http://www.eicc.info/>

B.7.1.1.2 SA8000

SA8000 is a global social accountability standard for decent working conditions, developed and overseen by Social Accountability International (SAI). SAI contracts with a global accreditation agency, Social Accountability Accreditation Services (SAAS) that licences and oversees auditing organisations to award certification to employers that comply with SA8000.

SA8000 is based on the UN Universal Declaration of Human Rights, Convention on the Rights of the Child and various International Labour Organization (ILO) conventions. SA8000 covers the following areas of accountability:

- **Child labour:** No workers under the age of 15; minimum lowered to 14 for countries operating under the ILO Convention 138 developing-country exception; remediation of any child found to be working.
- **Forced labour:** No forced labour, including prison or debt bondage labour; no lodging of deposits or identity papers by employers or outside recruiters.
- **Workplace safety and health:** Provide a safe and healthy work environment; take steps to prevent injuries; regular health and safety worker training; system to detect threats to health and safety; access to bathrooms and potable water.
- **Freedom of Association and Right to Collective Bargaining:** Respect the right to form and join trade unions and bargain collectively.
- **Discrimination:** No discrimination based on race, caste, origin, religion, disability, gender, sexual orientation, union or political affiliation, or age; no sexual harassment.
- **Discipline:** No corporal punishment, mental or physical coercion or verbal abuse.
- **Working hours:** Comply with the applicable law but, in any event, no more than 48 hours per week with at least one day off for every seven day period; voluntary overtime paid at a premium rate and not to exceed 12 hours per week on a regular basis; overtime may be mandatory if part of a collective bargaining agreement.
- **Remuneration:** Wages paid for a standard work week must meet the legal and industry standards and be sufficient to meet the basic need of workers and their families; no disciplinary deductions.
- **Management system for Human Resources:** Facilities seeking to gain and maintain certification must go beyond simple compliance to integrate the standard into their management systems and practices.

As documented proof we require:

1. A valid SA8000 certificate documenting compliance with the standard. The Brand owner shall be SA8000 certified or carrying out production at first tier production facilities that are SA8000 certified.
2. An annual list (that is not older than 12 months) of all third party audits conducted at the first tier production facilities of TCO certified products.
3. If the SA8000 certificate is not from a production facility, then one full report of

a third party audit (that is not older than 12 months) conducted at a first tier production facility of TCO certified products.

If the brand owner cannot present a full report that has been conducted during the last 12 months, then a final option is to buy one audit (for a subsidized fee) from a third party appointed by TCO Development.

If the Production facility has a valid SA8000 certificate, then no audit report need be submitted

More information:

<http://www.sa-intl.org/>

B.7.1.1.3 Self-documentation

Verification is made through completing a questionnaire provided by TCO Development. There are 10 questions concerning the brand owner's company work with implementing the minimum requirements on working conditions in the production of TCO Certified products. The answers shall be signed by the senior management representative and as far as possible supported by documentation.

To be accepted as fulfilling the TCO Development social criteria the brand owner company shall provide proof of having implemented structured CSR work with their first tier production facilities and make reasonable efforts with respects to suppliers. Our ambition is to ensure that the risk of the production not being in compliance with the requirements is minimized.

The questions cover such areas as the implementation and content of a code of conduct or similar demands on first tier production facilities, auditing and follow up of social criteria, trade union rights and representation, activities to avoid discrimination and the dialogue with suppliers.

As documented proof we require:

1. A completed and by CSR verifier approved TCO Development questionnaire. The Questionnaire and Guidelines for the assessment are public and can be downloaded at: www.tcodevelopment.com
2. An annual list (that is not older than 12 months) of all third party audits conducted at the first tier production facilities of TCO certified products.
3. One full report of a third party audit (that is not older than 12 months) conducted at a first tier production facility of TCO certified products.

If the brand owner cannot present a full report that has been conducted during the last 12 months, then a final option is to buy one audit (for a subsidized fee) from a third party appointed by TCO Development.

B.7.1.1.4 Brand owners not yet having the required CSR process in place (Grace Period).

Brand owners utilizing first tier production facilities that do not yet comply with the criteria are given a 12 month grace period to reach a level of engagement that complies.

In this case a signed guarantee by the brand owner stating an estimated date of compliance is required to be submitted with the application. It is then the verifier's responsibility to check that the brand owner has obtained a level of compliance within the grace period. If the necessary documentation is not received within the 12 month grace period then TCO Development shall be contacted by the verifier so a course of action can be decided.

B.7.1.1.5 On-site inspection instigated by the Brand owner (Social revision)

The third party auditor used by the applicant to carry out factory inspections and deliver the report, shall have documented experience of carrying out social auditing. The auditor should have undergone the SA8000 Advanced Auditor Training or an equivalent training course

B.7.1.1.6 On-site inspection instigated by TCO Development (Social revision)

TCO Development reserves the right to require full audit reports and conduct or commission on-site inspections at first tier production facilities to verify that the Brand owner is fulfilling the obligations according to this mandate. The planning of social audits will be done in cooperation with the Senior Management Representative appointed by the brand owner. Audits will be implemented by TCO Developments partner organisation for the actual geographic region. On factory level, inspections should be able to be unannounced visits. Social audits initiated by TCO Development will be realized on a judgement sample basis, in each case decided by and financed by TCO Development.