

TCO Certified All-in-one PCs 2.0



5 March 2012

Contents - TCO Certified All-in-one PCs

SUPPORT (ON THIS DOCUMENT AND TCO CERTIFICATION)	5
INTRODUCTION	6
A CRITERIA	7
A.1 GENERAL INFORMATION	7
A.1.1 TCO CERTIFIED DOCUMENT	8
A.2 VISUAL ERGONOMICS	9
A.2.1 IMAGE DETAIL CHARACTERISTICS	10
A.2.1.1 <i>Native display resolution requirement</i>	10
A.2.2 LUMINANCE CHARACTERISTICS	11
A.2.2.1 <i>Luminance level</i>	11
A.2.2.2 <i>Luminance uniformity</i>	12
A.2.2.3 <i>Black level</i>	13
A.2.2.4 <i>Luminance uniformity - angular-dependence</i>	14
A.2.2.5 <i>Greyscale gamma curve</i>	15
A.2.3 LUMINANCE CONTRAST CHARACTERISTICS.....	16
A.2.3.1 <i>Luminance contrast – characters</i>	16
A.2.3.2 <i>Luminance contrast – angular dependence</i>	17
A.2.4 REFLECTION CHARACTERISTICS.....	18
A.2.4.1 <i>Front frame gloss</i>	18
A.2.5 SCREEN COLOUR CHARACTERISTICS	20
A.2.5.1 <i>Correlated colour temperature, CCT, variation</i>	20
A.2.5.2 <i>Colour uniformity</i>	21
A.2.5.3 <i>RGB settings</i>	22
A.2.5.4 <i>Colour uniformity – angular dependence</i>	23
A.2.5.5 <i>Colour greyscale linearity</i>	24
A.3 WORK LOAD ERGONOMICS	25
A.3.1 VERTICAL TILT	26
A.3.2 VERTICAL HEIGHT ADJUSTMENT	27
A.4 EMISSIONS	28
A.4.1 ALTERNATING ELECTRIC FIELDS	29
A.4.2 ALTERNATING MAGNETIC FIELDS	30
A.4.3 ACOUSTIC NOISE.....	31
A.5 ELECTRICAL SAFETY	33
A.5.1 ELECTRICAL SAFETY.....	33
A.6 ENVIRONMENTAL REQUIREMENTS	34
A.6.1 PRODUCT DESCRIPTION.....	35
A.6.2 ORGANISATION.....	37
A.6.2.1 <i>Environmental management system certification</i>	37
A.6.3 CLIMATE.....	39
A.6.3.1 <i>Energy consumption</i>	39
A.6.3.2 <i>Energy consumption – external power supply</i>	40
A.6.4 ENVIRONMENTALLY HAZARDOUS SUBSTANCES.....	41
A.6.4.1 <i>Cadmium (Cd), mercury (Hg), lead (Pb) and hexavalent chromium (CrVI)</i>	41
A.6.4.2 <i>Halogenated substances</i>	43
A.6.4.3 <i>Non-halogenated substances</i>	45
A.6.4.4 <i>Plastics with chlorine and bromine as part of the polymer</i>	47
A.6.4.5 <i>Information regarding plastics, flame retarding agents and plasticizers</i>	49
A.6.5 PRODUCT LIFETIME.....	51
A.6.5.1 <i>Warranty and spare parts</i>	51
A.6.6 PREPARATION FOR RECYCLING.....	52

A.6.6.1	Material coding of plastics	52
A.6.6.2	Variety of plastics	54
A.6.6.3	Moulded-in metal parts and metallization of plastic housing	55
A.6.6.4	Preparation for recycling - Mercury lamps.....	56
A.6.6.5	Take back system	57
A.6.7	PRODUCT PACKAGING.....	59
A.6.7.1	Hazardous substances in product packaging	59
A.6.7.2	Preparation for recycling of product packaging material.....	60
A.7	CORPORATE SOCIAL RESPONSIBILITY	61
A.7.1	CORPORATE SOCIAL RESPONSIBILITY.....	61
A.7.2	SENIOR MANAGEMENT REPRESENTATIVE	63
R	REFERENCES	64
B	TEST METHODS AND CLARIFICATIONS.....	68
B.0	GENERAL TEST CONDITIONS.....	68
B.0.1	DEFINITION OF A TEST OBJECT	68
B.0.2	REQUIRED TEST OBJECT INFORMATION	68
B.0.3	CONDITIONS FOR THE EQUIPMENT UNDER TEST	68
B.0.4	ALL-IN-ONE PC ALIGNMENT FOR TESTING.....	69
B.0.5	INSTRUMENTS USED FOR TESTING.....	69
B.0.6	SETTINGS OF THE ALL-IN-ONE PC	69
B.0.7	TEST IMAGE/TEST CHARACTER	70
B.0.8	TEST IMAGE AND TEST LUMINANCE SETTING	70
B.0.9	TEST REPORT	72
B.1	GENERAL INFORMATION.....	73
B.1.1	TCO CERTIFIED DOCUMENT	73
B.2	VISUAL ERGONOMICS	74
B.2.0	GENERAL TEST CONDITIONS FOR VISUAL ERGONOMICS	74
B.2.0.1	Basic test requirements.....	74
B.2.0.2	Photometric laboratory general requirements	74
B.2.0.3	Power supply and test room climate requirements for testing	74
B.2.0.4	Photometric and spectrometric measurements.....	74
B.2.0.5	Measurement distance	76
B.2.0.6	Stray light.....	76
B.2.0.7	Overall uncertainty.....	76
B.2.1	IMAGE DETAIL CHARACTERISTICS.....	77
B.2.1.1	Native display resolution requirement	77
B.2.2	LUMINANCE CHARACTERISTICS	78
B.2.2.1	Luminance level.....	78
B.2.2.2	Luminance uniformity.....	79
B.2.2.3	Black level	80
B.2.2.4	Luminance uniformity – angular dependence	81
B.2.2.5	Greyscale gamma curve	85
B.2.3	LUMINANCE CONTRAST CHARACTERISTICS.....	86
B.2.3.1	Luminance contrast – characters	86
B.2.3.2	Luminance contrast – angular dependence.....	91
B.2.4	REFLECTION CHARACTERISTICS.....	92
B.2.4.1	Front frame gloss	92
B.2.5	SCREEN COLOUR CHARACTERISTICS	93
B.2.5.1	Correlated colour temperature (CCT) variation.....	93
B.2.5.2	Colour uniformity	94
B.2.5.3	RGB settings.....	96
B.2.5.4	Colour uniformity – angular dependence.....	96
B.2.5.5	Colour greyscale linearity.....	98

B.3	WORKLOAD ERGONOMICS.....	100
B.3.1	VERTICAL TILT	100
B.3.2	VERTICAL HEIGHT	100
B.4	EMISSIONS.....	101
B.4.0	GENERAL TEST CONDITIONS FOR EMISSIONS	101
B.4.0.1	<i>Basic test requirements.....</i>	101
B.4.0.2	<i>Conditions and set up for the test object</i>	101
B.4.0.3	<i>Emission measurement instruments.....</i>	104
B.4.1	ALTERNATING ELECTRIC FIELDS	108
B.4.2	ALTERNATING MAGNETIC FIELDS	111
B.4.3	ACOUSTIC NOISE.....	113
B.6	ENVIRONMENTAL REQUIREMENTS	114
B.6.0	GENERAL CLARIFICATION	114
B.6.0.1	<i>Signatures.....</i>	114
B.6.1	PRODUCT DESCRIPTION.....	114
B.6.2	ORGANISATION.....	114
B.6.2.1	<i>Environmental management system certification.....</i>	114
B.6.3	CLIMATE.....	115
B.6.3.1	<i>Energy consumption – All-in-one PC.....</i>	115
B.6.3.2	<i>Energy consumption – external power supply.....</i>	115
B.6.4	ENVIRONMENTALLY HAZARDOUS SUBSTANCES.....	116
B.6.4.1	<i>Cadmium (Cd), mercury (Hg), lead (Pb) and hexavalent chromium (CrVI).....</i>	116
B.6.4.2	<i>Halogenated substances</i>	116
B.6.4.3	<i>Non-halogenated substances</i>	117
B.6.4.4	<i>Plastics with chlorine and bromine as part of the polymer</i>	117
B.6.4.5	<i>Information regarding plastics, flame retarding agents and plasticizers.....</i>	118
B.6.5	PRODUCT LIFETIME.....	118
B.6.5.1	<i>Warranty and spare parts.....</i>	118
B.6.6	PREPARATION FOR RECYCLING.....	118
B.6.6.1	<i>Material coding of plastics</i>	118
B.6.6.2	<i>Variety of plastics</i>	118
B.6.6.3	<i>Metallization of plastic housing and metal parts.....</i>	119
B.6.6.4	<i>Preparation for recycling - Mercury lamps.....</i>	119
B.6.6.5	<i>Take back system</i>	119
B.6.7	PRODUCT PACKAGING.....	120
B.6.7.1	<i>Hazardous substances in product packaging</i>	120
B.7	CORPORATE SOCIAL RESPONSIBILITY	121
B.7.1.1	<i>General Clarifications.....</i>	121

Support (on this document and TCO Certification)

If you would like to certify your products and need support in understanding this document and the certification process, then TCO Development has partners that have laboratories around the world that can clarify this document and assist you with certification in your native language.

Please contact TCO Development for a list of partner laboratories:
certification@tcodevelopment.com

Or visit the TCO Development webpage for a list of partner laboratories:
www.tcodevelopment.com

Introduction

TCO Development has, since the end of the 1980s, influenced the development of IT equipment, particularly Visual Display Units (VDUs). Today, TCO Development's international certification system – TCO Certified – makes it easy to choose sustainably designed and produced IT and office equipment. It is a third party certification, Type 1 eco label according to ISO14024. The point of departure for this product group's criteria is the commitment to sustainability, whereby long term economic gains are dependent on social and environmental considerations. The criteria for TCO Certified include environmental and social aspects, and have been broadened from product focus to also include the production phase. This is a result of increased expectations around the world to respect human rights in the production and development of the products. The social responsibility criteria also cover quality aspects of the product, such as ergonomics, emissions and electrical safety. The criteria related to the environment include, for both product and production, aspects, such as energy consumption, content of hazardous materials, preparation for recycling and environmental management system at production sites.

With every major update of the criteria the aim is to extend and tighten the certification in order to keep in pace with technology innovation and development. All updates are a result of cooperation between key stakeholders, such as purchasers, users, producers, and researchers. This criteria document; TCO Certified All-in-one PCs 2.0, is the second version of TCO Development's certification of integrated PCs. Going forward, subsequent versions, 2.1, 2.2 etc., might be released. However, these are to be considered only as updates within the sixth version with improved precision of the mandates and test methods.

It is permitted to quote from these criteria (e.g. in procurements), provided that the source is disclosed and the extent of the quotation is consistent with sound copyright practice. For further information, please visit www.tcodevelopment.com.

Stockholm March 2012

TCO Development

Martin Söderberg
Business Area Manager PCs

A Criteria

A.1 General information

This document contains requirements, test methods and references for All-in-one PCs.

An All-in-one PC is defined as a PC and display in a single unit. Other terminology this document may cover is Integrated Network PCs and Thin Clients.

The aim of this criteria document is to provide relevant test methods and criteria for the actual use of the product. This criteria document has an A- and a B-part. The A-part includes the mandated criteria and the B-part clarifications and test methods.

Compliance to the mandates in this criteria document can be achieved in one of two ways. Those ways are either through a test report or through a verification report.

1. A test report is defined as a report based on:
 - Testing conducted by the laboratory issuing the test report on the product identified in the report.
2. A verification report is defined as a report based on:
 - A test report issued by a different laboratory.
 - Declarations from the Company applying for the certificate.

The alternatives accepted by TCO Development for each criterion can be found under each mandate respectively.

A.1.1 TCO Certified Document

Background

It is necessary that the purchaser of a product that has been certified in accordance with *TCO Certified All-in-one PCs* receives information concerning the quality, features and capabilities of the product. This information is based on the viewpoint from the user's perspective that TCO Development represents.

Applicability

All-in-one PCs.

References

The contract between TCO Development and the Applicant/Brand owner.

Mandate A.1.1:

A TCO Certified Document written in English or the native language where the product is to be sold shall accompany the product, describing why these particular requirements have been chosen for the products within the program of TCO Certified All-in-one PCs, and what is expected to be achieved by them. The document may be provided as an electronic file. An English version of the text can be obtained from TCO Development.

Examples of how the document can accompany the product are presented below:

- A separate printed document.
- As an electronic file or in the user manual.
- At the manufacturer's web site, together with the information about the product. A reference to the web site shall accompany the product

The following information shall be submitted to the verifier at the test laboratory:

A written guarantee that the above mandate is fulfilled. The document shall be signed by the responsible person at the applicant company.

The following information shall be submitted with the application to TCO Development:

A copy of a verification report from a test laboratory approved by TCO Development.

We hereby guarantee that the above mandate is fulfilled.

.....
Product brand and model name

.....
Signature

.....
Name and title in block capitals

.....
Date

.....
Company

A.2 Visual ergonomics

Today PC displays are an essential tool for users in all kinds of environments. Good visual ergonomics is a very important aspect of quality that can also have a direct effect on the health, comfort and performance of the user.

In developing requirements for visual ergonomics, the possible health effects of various parameters have been taken into account. Other features that characterise good quality displays have also been in focus for developing these criteria.

TCO Development used three main methodologies to determine the suitable level for each requirement and the test methods for the visual ergonomics part of the TCO Certified labelling program. One is based on acceptable visual levels, as determined by scientific research. The second is based on statistics from tests carried out in accordance with TCO Development, ISO, MPR regulations and from specialized VDU tests. The third way is based on manufacturers' knowledge and experience, which is invaluable. Manufacturers, consumer groups and other organisations with interests in the visual ergonomics field have contributed a great deal of valuable information and ideas throughout the development process.

A.2.1 Image detail characteristics

A.2.1.1 Native display resolution requirement

Background

Image quality is negatively affected by a low fill factor, visible “jaggies”, poor rendering of details, etc. All of these parameters are related to the resolution of the display. For display resolution characteristics, it is important to take the viewing distance into account.

The viewing distance in this TCO criteria document is defined as $1.5 \times$ the display diagonal, but no less than 500 mm which could be considered as an absolute minimum viewing distance for comfortable viewing. This means that the mandate on resolution is independent of the display size and viewing distance but dependent on the display format. Only the display format needs to be known.

Definition

A pixel is the smallest addressable imaging element of the All-in-one PC display capable of reproducing a full range of luminance and colours.

The native display resolution is the number of pixels in the horizontal direction by the number of pixels in the vertical direction that the display can present.

Applicability

All-in-one PCs.

Test procedure

See B.2.1.1.

References

2, 36 and 44.

Mandate A.2.1.1:

The pixel density shall be ≥ 30 pixels/degree visual angle.

The following information shall be submitted with the application to TCO Development:

A copy of a test report from a test laboratory approved by TCO Development.

A.2.2 Luminance characteristics

A.2.2.1 Luminance level

Background

It shall be possible to set the luminance level according to the lighting conditions of the surroundings. Poor luminance can lead to low contrast and consequently affect legibility and colour discrimination and thus lead to misinterpretations. It shall be possible to set a sufficiently high luminance level with respect to the ambient lighting in order to present a comfortable viewing situation and to avoid eyestrain. It is also important that it is possible to set the luminance to a suitable level in low ambient light i.e. 100 cd/m².

Definition

Luminance being emitted from a particular area is a measure of the luminous intensity per unit area of light travelling in a given direction and falls within a given solid angle.

The unit of luminance is cd/m².

Applicability

All-in-one PCs.

Test procedure

See B.2.2.1.

References

1, 2, 18, 21, 27, 31, 36 and 44.

Mandate A.2.2.1:

The following conditions shall be fulfilled:

- The luminance at default setting shall be ≥ 150 cd/m²
- The maximum luminance shall be ≥ 200 cd/m²
- The minimum luminance shall be ≤ 100 cd/m²

The following information shall be submitted with the application to TCO Development:

A copy of a test report from a test laboratory approved by TCO Development.

A.2.2.2 Luminance uniformity

Background

Image quality is badly affected by non-uniform luminance. When poor luminance uniformity is visible, it can locally affect the contrast and consequently the legibility of information on the display. The areas of deviating luminance can have different sizes and cause varying contour sharpness.

Definition

Luminance uniformity is the capacity of the All-in-one PC display to maintain the same luminance level over the whole active screen area. The luminance uniformity is defined as the ratio of maximum to minimum luminance within the fully active screen area.

Applicability

All-in-one PCs.

Test procedure

See B.2.2.2.

References

1, 2, 16, 18, 21, 22, 27, 32, 33, 36 and 44.

Mandate A.2.2.2:

Luminance variation across the active screen, $L_{\max} : L_{\min}$ shall be ≤ 1.50

The following information shall be submitted with the application to TCO Development:

A copy of a test report from a test laboratory approved by TCO Development.

A.2.2.3 Black level

Background

It is important that a display can produce a black level dark enough to show shadow details in pictures at high and low white luminance levels.

Definition

Black level is the capacity of the display to maintain a good reproduction of black even when its luminance is high.

Applicability

All-in-one PCs.

Test procedure

See B.2.2.3.

References

51

Mandate A.2.2.3:

The luminance of black shall be $\leq 2 \text{ cd/m}^2$ at a white luminance setting of $\geq 200 \text{ cd/m}^2$.

The following information shall be submitted with the application to TCO Development:

A copy of a test report from a test laboratory approved by TCO Development.

A.2.2.4 Luminance uniformity - angular-dependence

Background

The luminance of an All-in-one PC display is angular-dependent , i.e. screen luminance decreases when the display is viewed slightly from the side horizontally or vertically. This can have a negative effect on contrast and can affect the legibility of the display.

Definition

Luminance uniformity – angular dependence, is the capacity of the All-in-one PC display to maintain a certain luminance level independently of the viewing direction. The angular-dependent luminance uniformity is defined as the ratio of maximum luminance to minimum luminance in the specified measurement areas.

Applicability

All-in-one PCs.

Test procedure

See B.2.2.4.

References

1, 16, 22, 27, 31, 32 and 33.

Mandate A.2.2.4:

- 1) In landscape mode, when the screen is rotated around the vertical axis through the centre of the screen the mean value of the L_{max} to L_{min} ratios at $\pm 30^\circ$ shall be ≤ 1.73 .
- 2) In landscape mode, when the screen is rotated around the horizontal axis through the centre of the screen, the largest value of the L_{max} to L_{min} ratios at $\pm 15^\circ$ shall be ≤ 1.73 .

The following information shall be submitted with the application to TCO Development:

A copy of a test report from a test laboratory approved by TCO Development.

A.2.2.5 Greyscale gamma curve

Background

A TCO Certified All-in-one PC shall be delivered with a calibrated gamma curve in default preset since it makes it easier to distinguish between similar light levels. A well-tuned greyscale is the basis for accurate detail rendering of any imaging device. The greyscale rendering is measured via a number of steps in a greyscale in the test image. Each greyscale step, regardless of grey level, shall have a luminance level close to what is specified by the common standard sRGB in order to give accurate rendering of the greyscale of the original image. With special software or hardware calibration tools it may be possible to achieve a better calibrated gamma curve than the TCO Certified criteria and also in other presets than the default one.

Definition

Greyscale gamma curve is the capability of the imaging device to maintain the original greyscale luminance or a greyscale pattern at all tested greyscale levels.

Applicability

All-in-one PCs.

Test procedure

See B.2.2.5

References

11, 12, 13, 14, 20, 51, 52 and 72.

Mandate A.2.2.5:

The different greyscale luminance levels shall be within the Max- and Min levels according to the table below, where 100% means the luminance level measured for white, RGB 255, 255, 255.

Grey level	L_{sRGB} %	L_{min} %	L_{max} %
255	100	100,0	100,0
225	75	70	93
195	55	46	68
165	38	29	49
135	24	17	36
105	14	8	24
75	7	3	14
45	3	1	7

The following information shall be submitted with the application to TCO Development:

A copy of a test report from a test laboratory approved by TCO Development.

A.2.3 Luminance contrast characteristics

A.2.3.1 Luminance contrast – characters

Background

The degree of contrast is important for legibility and for distinguishing one character from another.

Definition

Luminance contrast – characters is the capacity of the All-in-one PC display to maintain a high luminance difference between a bright background and dark characters or parts of characters over the whole active area.

Luminance contrast – characters is expressed as the ratio of the L_{\max} to L_{\min} difference over the sum of L_{\max} and L_{\min} , in accordance with Michaelson's formula.

Applicability

All-in-one PCs.

Test procedure

See B.2.3.1.

References

2, 16, 19, 20, 22, 23, 27, 32 and 44.

Mandate A.2.3.1:

The luminance contrast shall be ≥ 0.70 measured orthogonally to the screen.

The following information shall be submitted with the application to TCO Development:

A copy of a test report from a test laboratory approved by TCO Development.

A.2.3.2 Luminance contrast – angular dependence

Background

For All-in-one PC displays the luminance and consequently the contrast on the display is angular-dependent. The luminance variations can influence both the bright white and the dark areas of the screen, causing a change in contrast. This can have a negative effect on the legibility of the display.

Definition

Luminance contrast – angular dependence, is the capability of the All-in-one PC displays to maintain the same contrast regardless of the direction from which the screen is viewed. Luminance contrast – angular dependence, is expressed as the ratio of the L_{\max} to L_{\min} difference over the sum of L_{\max} and L_{\min} , in accordance with Michaelson's formula. It is measured at two different angles.

Applicability

All-in-one PCs.

Test procedure

See B.2.3.2.

References

2, 16, 19, 20, 23, 28 and 33.

Mandate A.2.3.2:

In landscape mode, the luminance contrast-angular dependence shall be ≥ 0.80 at $\pm 30^\circ$ horizontally from the viewing direction (rotated around the vertical axis through the centre of the screen).

The following information shall be submitted with the application to TCO Development:

A copy of a test report from a test laboratory approved by TCO Development.

A.2.4 Reflection characteristics

A.2.4.1 Front frame gloss

Background

Front frame gloss may influence visual comfort and legibility by drawing attention away from the task at hand. The higher the gloss value the more likely it is that the surface will create specular reflections (mirror-like reflections) from ambient lighting and bright surfaces. If the gloss value and the ambient light are high enough, the problem of reflected images may occur.

However, in a controlled ambient light, reflections can be avoided by changing light intensity or moving light sources or the display, making the problem with a glossy frame less relevant.

Definition

Gloss is a measure of how a light beam, physically described as luminous flux, is scattered at the surface when incident against that surface. Gloss is a function of the directional reflectance properties of a surface.

Applicability

All-in-one PCs

Test procedure

See B.2.4.1.

References

5, 6, 7 and 37.

Mandate A.2.4.1:

For bezels that have a gloss value $G(60^\circ) > 30$ gloss units the following consideration note for the placement of the product shall be given in the language of the user manual.

“For displays with glossy bezels the user should consider the placement of the display as the bezel may cause disturbing reflections from surrounding light and bright surfaces.”

The following information shall be submitted to the verifier at the test laboratory:

For bezels with > 30 gloss units a written guarantee that the above mandate is fulfilled must be provided. The document shall be signed by the responsible person at the applicant company.

The following information shall be submitted with the application to TCO Development:

A copy of a test report and a verification report from a test laboratory approved by TCO Development.

We hereby guarantee that the above mandate is fulfilled.

.....
Product brand and model name

.....
Signature

.....
Name and title in block capitals

.....
Date

.....
Company

A.2.5 Screen colour characteristics

A.2.5.1 Correlated colour temperature, CCT, variation

Background

For All-in-one PC displays equipped with pre-set correlated colour temperature settings. These settings make it possible to more accurately evaluate the colour of an image on the display compared to real scenes or prints.

Physical measurements of colour stimuli can only give an indication of the colour appearance in a practical situation. The colour of the frame, the spectral composition of the lighting, the colour of various areas in the visual field, and the complexity of brightness variations in the visual field all influence the colour appearance of a display image.

Normal daylight has a correlated colour temperature in the range 5000 – 10000 K.

For the editing of photos or video, it is important to be able to set a colour temperature of 6500 K or sRGB, since most productions are made using that standard.

Definition

The correlated colour temperature is a measure of the perceived screen colour expressed in kelvin (K).

Applicability

All-in-one PCs.

Test procedure

See B.2.5.1.

References

Please see reference 2, 3, 4, 8-12, 14, 15, 17, 24, 25, 26, 28, 30, 34, 36 and 38.

Mandate A.2.5.1:

The correlated colour temperature of the active display shall be in the range 5000K to 10000K.

For All-in-one PCs with Correlated Colour Temperature pre-sets, each pre-set shall have a colour difference $\Delta u'v' \leq 0.012$ when compared to CIE u' and v' chromaticity co-ordinates for corresponding correlated colour temperatures.

The following information shall be submitted with the application to TCO Development:

A copy of a test report from a test laboratory approved by TCO Development.

A.2.5.2 Colour uniformity**Background**

The human visual system is very sensitive to changes in colour hue in white and grey areas. Since the white or grey colour hues are the background on which most colours are judged, the white or grey areas are the reference colours on the screen.

Patches of colour variation on an active white or grey screen could reduce the contrast locally, be disturbing and affect the legibility, colour rendering and colour differentiation.

Definition

The colour uniformity of an All-in-one PC display is the capability to maintain the same colour in any part of the screen.

Applicability

All-in-one PCs.

Test procedure

See B.2.5.2.

References

Please see reference 2, 8, 14, 15, 23, 25, 29, 35, 36 and 38.

Mandate A.2.5.2:

The maximum colour deviation between measured active areas on the screen that are intended to maintain the same colour shall be $\Delta u'v' \leq 0.012$.

The following information shall be submitted with the application to TCO Development:

A copy of a test report from a test laboratory approved by TCO Development.

A.2.5.3 RGB settings

Background

Accurate colour rendering is important when realistic colour images or colour presentations are presented on the All-in-one PC display. Poor colour rendering can lead to poor legibility and misinterpretation. The u' and v' chromaticity co-ordinates of the primary colours red (R), green (G) and blue (B) of the screen shall aim at values given in international IEC, EBU and ITU standards. The u' and v' chromaticity co-ordinates of the primary colours R, G and B form a triangle in the CIE 1976 uniform chromaticity scale diagram. The larger the area of the triangle, the wider the range of colours the screen is capable of presenting.

Definition

The colour characteristics of an All-in-one PC display are based on the visual appearance of the display's primary colour stimuli, the R, G, B-stimuli.

Applicability

All-in-one PCs.

Test procedure

See B.2.5.3.

References

Please see reference 3, 4, 8-15, 17, 25, 26, 28, 30, 34, 36 and 38.

Mandate A.2.5.3:						
The minimum colour triangle shall have the following coordinates:						
	Red		Green		Blue	
Co-ordinate	u'	v'	u'	v'	u'	v'
Requirement	≥ 0.411	≥ 0.503	≤ 0.140	≥ 0.548	≥ 0.150	≤ 0.210
<p>The following information shall be submitted with the application to TCO Development:</p> <p>A copy of a test report from a test laboratory approved by TCO Development.</p>						

A.2.5.4 Colour uniformity – angular dependence**Background**

The human visual system is very sensitive to changes in colour hue in white and grey areas. Since the white or grey colour hues are the background on which most colours are judged, the white or grey areas are the reference colours on the screen. Angular-dependent colour variations on an active white or grey screen could be disturbing and affect legibility, colour rendering and colour differentiation.

Definition

The colour uniformity – angular dependence of an All-in-one PC display is the capability of the display to maintain constant colour over the screen surface depending of the direction from which the screen is viewed.

Applicability

All-in-one PCs.

Test procedure

See B.2.5.4.

References

Please see reference 2, 8, 14, 15, 23, 25, 29 and 35.

Mandate A.2.5.4:

In landscape mode, the $\Delta u'v'$ between areas on the left side and the right side of the screen when it is positioned at $+30^\circ$ and at -30° horizontally to the screen normal (rotated around the vertical axis through the centre of the screen) shall be $\Delta u'v' \leq 0.025$.

The following information shall be submitted with the application to TCO Development:

A copy of a test report from a test laboratory approved by TCO Development.

A.2.5.5 Colour greyscale linearity

Background

A well-tuned colour greyscale is the basis for good colour rendering on the screen. This is measured via steps in a greyscale on the screen. Each greyscale step shall have similar colour hues in order to simplify colour interpretation and to avoid confusion for the user, only the luminance shall vary.

Definition

Colour greyscale linearity is the capability of the screen to maintain the same u',v' co-ordinates of a greyscale pattern at all greyscale levels, i.e. only the luminance shall change from one greyscale step to the next.

Applicability

All-in-one PCs.

Test procedure

See B.2.5.5.

References

Please see reference 2, 8, 14, 15, 23, 25, 29 and 35.

Mandate A.2.5.5:								
Table A.2.5.5								
Greyscale	Maximum $\Delta u'v'$ difference							
	255	225	195	165	135	105	75	45
255	0							
225	0.015	0						
195	0.015	0.015	0					
165	0.020	0.020	0.020	0				
135	0.025	0.025	0.020	0.020	0			
105	0.025	0.025	0.025	0.025	0.020	0		
75	0.035	0.035	0.035	0.035	0.035	0.025	0	
45	0.035	0.035	0.035	0.035	0.035	0.035	0.035	0

The $\Delta u'v' \leq$ the maximum allowed difference for each step according to table A.2.5.5.

The following information shall be submitted with the application to TCO Development:

A copy of a test report from a test laboratory approved by TCO Development.

A.3 Work load Ergonomics

Work load ergonomics refers to the adaptation of the task, tools, work place and physical environment where the product will be used. These requirements are put in place in order to meet and optimize the users' needs for a good work environment.

PC equipment is, just as much as furniture, lighting and other equipment, an important part of the modern environment where IT products are used. TCO Development wants to contribute to the development of All-in-one PC displays with good user characteristics, on the basis of work load ergonomics. This thereby enhances the possibility for users to be able to have good quality display so that the best possible conditions for physical variation are created in the user's environment.

It is important for All-in-one PC display to offer users the possibility of variation between different work postures. An aesthetically appealing design should not restrict the work load ergonomics function.

Displays larger than 26" are not normally used on a work desk since the viewing distance is considered to be too close. They are also not considered to be easily movable on a normal display stand but are often placed on wall mounts. They are therefore excluded from these requirements.

As a further complement and support for users, ergonomic user instructions are available in "the Advisor" on TCO Development's webpage <http://www.tcodevelopment.com>.

A.3.1 Vertical tilt

Background

It is a benefit to be able to tilt the All-in-one PC display in the vertical plane. This offers the possibility to tilt the display back in order to have a 90 degrees viewing angle. This ability to tilt the display offers the user the option of altering work posture for maximum comfort and also to obtain and utilise the best visual ergonomics of the display.

Applicability

All-in-one PCs $\leq 26''$.

Clarification

B.3.1

References

Please see references 39-48.

Mandate A.3.1:
All-in-one PC displays $\leq 26''$ shall achieve a backwards tilt of at least 20 degrees in the vertical plane.
The following information shall be submitted to the verifier at the test laboratory:
A written guarantee that the mandate is fulfilled. The guarantee shall be signed by the responsible person at the applicant company.
The following information shall be submitted with the application to TCO Development:
A copy of a verification report from a test laboratory approved by TCO Development.

We hereby guarantee that the above mandate is fulfilled.

.....
Product brand name and model name

.....
Signature

.....
Name and title in block capitals

.....
Date

.....
Company

A.3.2 Vertical height adjustment

Background

It is important to position the display so that it can be viewed within a line of sight angle between horizontal and 60 degrees below the horizontal. The height adjustment system should allow positioning of the top of the display at, or slightly below, the seated eye height of the average male or average female range of operators when the All-in-one PC display is placed on a standard height (750 mm) table. A height adjustment function, especially the lowering of the All-in-one PC display down towards the work top surface, is beneficial for the possibility of work posture flexibility to be able to get the best visual ergonomics of the display.

Applicability

All-in-one PCs $\leq 26''$.

Clarification

B.3.2

References

Please see references 39-49, 76 and 77.

Definition

Work top surface: the surface where the All-in-one PC display is positioned.

Mandate A.3.2:

All-in-one PC displays $\leq 26''$ shall meet at least *one* of the following mandates:

1. With the display aligned vertically in its lowest point of height adjustment, the distance measured from the underside of the display's foot (work top surface) to the upper edge of the active screen area shall be ≤ 42 cm.
2. The All-in-one PC display shall have a mounting interface applicable to the VESA mounting interface standard.

The following information shall be submitted to the verifier at the test laboratory:

A written guarantee that the All-in-one PC display meets one of the mandates. The guarantee shall be signed by the responsible person at the applicant company.

The following information shall be submitted with the application to TCO Development:

A copy of a verification report from a test laboratory approved by TCO Development.

We hereby guarantee that the above mandate is fulfilled.

.....
Product brand and model name

.....
Signature

.....
Name and title in block capitals

.....
Date

.....
Company

A.4 Emissions

Users of IT equipment increasingly have several nearby electrical and magnetic field sources placed on work surfaces that they are exposed to. The permanent relationship of the body to certain field sources, such as visual distance from displays, mobile telephone location next to the ear and the proximity of task-specific lighting are realities that exacerbate the situation.

When the first TCO Development label was introduced in 1992 for displays one of the main interests was the requirements for electrical and magnetic fields. To this day scientists and experts are divided on the question if these fields pose any health risks to humans.

Due to continued public concern and the increasing amount of emissions surrounding us, TCO Development remains convinced that the criteria in our documents are still highly relevant, even with today's slim lined products. TCO Certified emission criteria are created to make certain that internal shielding is used to ensure that a TCO Certified product's emissions are at a technically achievable low level and will not raise normal background levels when the product is used in a working environment.

TCO Certified criteria cover emissions around the product since it may be placed there persons, other than the user, are working in close proximity. Even with wall mounted displays, consideration to emission levels shall be given to what may be in close proximity on the other side of the wall.

A.4.1 Alternating electric fields

Background

Electrical alternating fields are created between objects that have different levels of electrical potential which change over time. When the potential changes in a periodic manner, an electrical alternating field is set up, with a field strength and a frequency. A display contains many sources of electrical alternating fields. The field characteristics depend on the actual electrical potential difference and the distance from the All-in-one PC display.

IT users are often concerned about a possible health risk arising from electrical alternating fields generated by equipment. Quite a large number of users also report various kinds of symptoms that cannot completely be attributed to the influence of other factors in their environment or to medical reasons.

The mandatory requirements are based on the ambition to reduce the electrical alternating fields to such a low level so as not to burden the work and home environment with unnecessary factors. The mandatory requirements shall not be regarded as hygienic limit values.

Applicability

All-in-one PCs

Test procedure

See B.4.1.

References

-

Mandate A.4.1:**Band I: 5 Hz to 2 kHz, ≤ 10 V/m**

All-in-one PC displays ≤ 26 " are measured at 0.30 m and 0.50 m in front of the product.

All-in-one PC displays > 26 " are measured at 0.50 m in front of the product.

Band II: 2 kHz to 400 kHz, ≤ 1.0 V/m

All-in-one PC displays ≤ 26 " are measured at 0.30 m in front of- and 0.50 m from the surface around the product.

All-in-one PC displays > 26 " are measured at 0.50 m from the surface around the product.

The following information shall be submitted with the application to TCO Development:

A copy of a test report from a test laboratory approved by TCO Development

A.4.2 Alternating magnetic fields

Background

Magnetic alternating fields are created when an electrical alternating current flows through a conductor. Like other electrical equipment, All-in-one PCs are surrounded by magnetic alternating fields. These magnetic alternating fields are generated by different parts of the product, e.g. power supply unit, voltage inverters and other electrical circuits. The field strength depends on the actual electric current and on the distance from the All-in-one PC.

IT users are often concerned about a possible health risk arising from electrical alternating fields generated by equipment. Quite a large number of users also report various kinds of symptoms that cannot completely be attributed to the influence of other factors in their environment or to medical reasons.

The mandatory requirements are based on the ambition to reduce the magnetic alternating fields to such a low level as not to burden the work and home environment with unnecessary factors. The mandatory requirements shall not be regarded as hygienic limit values.

Applicability

All-in-one PCs

Test procedure

See B.4.2.

References

-

Mandate A.4.2:**Band I: 5 Hz to 2 kHz, ≤ 200 nT**

All-in-one PC displays ≤ 26 " are measured at 0.30 m in front of- and at 0.50 m around the product.

All-in-one PC displays > 26 " are measured at 0.50 m from the surface of the product around the product.

Band II: 2 kHz to 400 kHz, ≤ 25 nT

All-in-one PC displays are measured at 0.50 m from the surface around the product.

The following information shall be submitted with the application to TCO Development:

A copy of a test report from a test laboratory approved by TCO Development

A.4.3 Acoustic noise

Background

Acoustic noise from fans, hard disk drives, etc. can be annoying. To prevent such annoyance, the aim shall be that All-in-one PCs shall cause a minimum of noise during usage. Many end users are sensitive to noise with different characteristics. To give the end-user a possibility to choose a product with a comfortable noise level and frequency characteristics generated by a product, this information should be declared, together with all other data related to a certain product.

Definitions

To be able to provide information about acoustic noise levels that permits comparison between different PCs the declared A-weighted sound power level (L_{WAd}) in operating and idling mode measured in accordance with ISO 9296 shall be reported. The following definitions apply:

Sound power level (L_W):

Total emitted sound power from a sound source, given in bels (B) and with the reference 1 pW .

A-weighting:

The measured linear sound level (sound pressure or sound power) weighted against the sensitivity of the human ear for different frequencies (A-curve).

Declared A-weighted sound power level (L_{WAd}): in bels (B). Defined in accordance with ISO 9296 3.2.5.

Operating mode. A condition in which the system and hard disk drive shall be operated in accordance with ECMA-74 C.15.3.2 and C.9.3.2.

Idling mode. A condition in which the system shall be operated in accordance with ECMA-74 C.15.3.1.

Applicability

All-in-one PCs with integrated moving parts.

Test procedure

See B 4.3 and ISO 7779:2010

References

78-84

Mandate A.4.3:

For AIO PCs with integrated moving parts, such as; motor driven hdd, fans, etc

1. The *declared A-weighted sound power level (LWAd)* shall not exceed:

Operating mode: 4.4B

Idling mode: 3.9B

If the product does not emit prominent discrete tones according to procedures specified in ECMA 74 Annex D a higher declared A-weighted sound power level (LWAd) is accepted but shall not exceed:

Operating mode: 4.7B

Idling mode: 4.2B

2. The A-weighted sound power level for a product shall be declared in the product data sheet and/or in any other product descriptions.

The following information shall be submitted with the application to TCO Development:

A copy of a test report from a test laboratory approved by TCO Development.

A.5 Electrical safety

A.5.1 Electrical safety

Background

Electrical safety concerns the electrical design of apparatus with respect to its electrical insulation and other arrangements that are intended to prevent accidents resulting from contact with live components, and the risk of fire or explosion as a result of electrical flash-over due to inadequate or faulty electrical insulation.

Applicability

All-in-one PCs with built-in power supplies as well as any separate power supply intended to be used together with the All-in-one PC.

References

Please see reference 50.

Mandate A.5.1:

The All-in-one PC and external power supply/supplies shall be certified according to EN/IEC 60 950 or EN/IEC 60 065.

The following information shall be submitted with the application to TCO Development:

A copy of a CB certificate or a national certificate from a CB member (NCB) shall be submitted.

A.6 Environmental requirements

The TCO Certified requirements combine a unique integrated balance of indoor and outdoor environmental issues. Achieving a good working environment should not be at the expense of the natural environment. This document details the environmental requirements of the TCO Certified label.

The Environmental requirements are divided into the following sections:

1. Organisation – requirements focusing on the production phase, environmental management and social responsibility.
2. Climate – energy consumption, one of the most important issues in the environmental impact of IT products.
3. Hazardous Substances – heavy metals, flame retardants, plastics.
4. Product Lifetime – factors to extend the life of the product.
5. Preparation for Recycling – factors to stimulate recycling.
6. Packaging – hazardous substance content and recycling.

Potential environmental effects are evident at each stage of the product life cycle. Due to the complexity of the production of ICT products, it is often most effective to refer to indirect requirements on the production such as requirements for an environmental management system. Should a more direct quality-assured system for manufacturing processes become possible, TCO Development would consider that option for future requirements. The environmental requirements TCO Development has focused on in this criteria document are those that we consider most relevant to the product group. They have also proved to be attainable in volume production and are verifiable. Future updates of the criteria document will likely focus on hazardous substances, social responsibility and climate issues.

All requirements except section *A.6.3 Climate* shall be verified by sending the requested information to a verifier at a test laboratory approved by TCO Development. The energy consumption requirements in section *A.6.3* shall be tested at a test laboratory approved by TCO Development.

A.6.1 Product description

Background

The aim of this product description is to provide information about the product that is to be reviewed for compliance with the environmentally related requirements of Section A.6 and also for information collection.

Definitions

Marking plate /Marking label is the label that contains the product's electrical rating in terms of voltage, frequency, current and the manufacturer's name, trademark or identification mark together with the manufacturer's model or type reference. The label shall be in accordance with IEC 60 950:1 clause 1.7.1.

Applicability

All-in-one PCs.

Clarification

B.6.1

References

53.

Mandate A.6.1:

A product declaration shall be provided for the All-in-one PC.

The following information shall be submitted to an approved verifier:

1. The declaration below, completed where applicable.
2. A copy of the marking label for the All-in-one PC and any external power supply.

The information submitted shall be signed by the responsible person at the applicant company.

The following information shall be submitted with the application to TCO Development:

A copy of a verification report from a verifier approved by TCO Development and a copy of the marking label.

All-in-one PC Declaration

All-in-one	Information
Manufacturer	
Brand name	
Brand owner	
Type/Model name	
Product Family name	

Panels	Information
Manufacturer	
Type/Model name	
Brand name	
Size and technology (e.g. 22" / TN type)	

External power supply: Brand & model name	Rating & Class

TCO Certified Certificate holder

We hereby guarantee that the above mandate is fulfilled.

.....
Product brand name and model name

.....
Signature

.....
Name and title in block capitals

.....
Date

.....
Company

A.6.2 Organisation

A.6.2.1 Environmental management system certification

Background

A certified environmental management system is proof that the company shows concern for the environment and has chosen to work in a systematic way with constant improvement of the environmental performance of the company and its products in focus. A certified environmental management system includes external independent reviews.

Definitions

Manufacturing plant: Production facility where the final assembly of the TCO certified product is taking place.

Applicability

The company or companies which manufacture the All-in-one PC.

Clarification

B.6.2.1

References

54 and 55.

Mandate A.6.2.1:

Each *manufacturing plant* must be certified in accordance with ISO 14001, or EMAS registered. If the product is manufactured by a third party, it is this company that shall be certified or registered.

If the *manufacturing plant* does not have an ISO 14001 certificate or EMAS registration at the time of application, the *manufacturing plant* is given a 12-month grace period to obtain ISO14001 certification or EMAS registration.

The following information shall be submitted to an approved verifier:

1. A document showing the names and addresses of the manufacturing plants.
2. Copy of the ISO 14001 certificate or EMAS registration or, when not available, an estimated date of certification/registration.
3. A written guarantee that the certificate/registration is valid and that the mandate above is fulfilled, signed by the responsible person at the applicant company.

The following information shall be submitted with the application to TCO Development:

A copy of a verification report from a verifier approved by TCO Development.

We hereby guarantee that the above mandate is fulfilled.

.....
Product brand name and model name

.....
Signature

.....
Name and title in block capitals

.....
Date

.....
Company

A.6.3 Climate

A.6.3.1 Energy consumption

Background

Energy is the single most important topic in the issue of climate change. Energy efficient equipment is an important and effective way to fight climate change. With an ever-increasing volume of IT equipment in use, the efficiency of each product is vital.

This requirement and test method is based on the most recently published Energy Star standard for computers.

Definitions

The energy consumption requirement in accordance with the most recently published Energy Star® standard for computers.

Applicability

All-in-one PCs.

Test procedure

B.6.3.1

References

60.

Mandate A.6.3.1:

The energy consumption requirements in the most recently published Energy Star® standard for computers on the date of application shall be fulfilled and verified through testing by a test laboratory approved by TCO Development.

The following information shall be submitted with the application to TCO Development:

A copy of a test report from a test laboratory approved by TCO Development.

A.6.3.2 Energy consumption – external power supply

Background

Energy is the single most important topic in the issue of climate change. Energy efficient equipment is an important and effective way to fight climate change. With an ever-increasing volume of IT equipment in use, the efficiency of each product is vital. To reduce energy consumption from the product the external power supply shall comply with the International Efficiency Marking Protocol for External Power Supplies.

Applicability

All external power supplies.

Clarification

B.6.3.2

References

61.

Mandate A.6.3.2:

The external power supply shall meet at least the International Efficiency Protocol requirement for level V

The following information shall be submitted to the verifier at the test laboratory:

A copy of the marking label for the external power supply

The following information shall be submitted with the application to TCO Development:

A copy of the marking label for the external power supply

A.6.4 Environmentally hazardous substances

A.6.4.1 Cadmium (Cd), mercury (Hg), lead (Pb) and hexavalent chromium (CrVI)

Background

The effects of the listed substances are well documented as environmental hazardous substances. EU regulated these substances in the RoHS directive (2002/95/EC) and continues to do so in the RoHS2 Directive (2011/65/EU).

Applicability

All-in-one PCs.

Clarification

B.6.4.1

References

62 and 63.

Mandate A.6.4.1:

1. The All-in-one PC shall not contain cadmium, mercury, lead and hexavalent chromium.

Note: This applies to components, parts, and raw materials in all assemblies and sub-assemblies of the product e.g. paint, surface treatment, plastics and electronic components.

2. The maximum level of mercury in background lighting systems allowed is 3,5 mg Hg/lamp. See B.6.4.1 for clarifications.

3. The total amount of mercury in the lamps shall be declared in the “Mercury declaration template” below.

The following information shall be submitted to an approved verifier:

1. A written guarantee that the above mandate is fulfilled. The guarantee shall be signed by the responsible person at the applicant company.

2. A declared “Mercury declaration template” below.

The following information shall be submitted with the application to TCO Development:

A copy of a verification report from a verifier approved by TCO Development.

We hereby guarantee that the above mandate is fulfilled.

.....
Product brand name and model name

.....
Signature

.....
Name and title in block capitals

.....
Date

.....
Company

Mercury declaration template

Display brand name:.....

Display type/model name:.....

FPD size:

Panel manufacturer:.....

Panel identification code:

Panel technology

Mercury lamp supplier:	Lamp ID code:	Lamp length (mm)	Max. mg Hg/lamp:

We hereby guarantee that the above mandate is fulfilled.

.....
Product brand name and model name

.....
Signature

.....
Name and title in block capitals

.....
Date

.....
Company

A.6.4.2 Halogenated substances

Background

Brominated and chlorinated flame retardants and other halogenated substances are often persistent, can bioaccumulate in living organisms and have been detected in flora and fauna.

A series of international elimination activities in respect to brominated and chlorinated flame retardants is currently in progress within several national and international bodies, e.g EU, OECD and North Sea Conference.

Definitions

Plastic parts are parts made mainly of plastics, e.g. the housing. Parts containing other materials in any significant amounts, e.g. cables with metal conductors, are not included in the definition.

Printed wiring board laminate is a printed board that provides point-to-point connections but not printed components in a predetermined configuration on a common base.

Applicability

All-in-one PCs.

Clarification

B.6.4.2

References

64.

Mandate A.6.4.2:

1. *Plastic parts* weighing more than 25 grams shall not contain flame retardants or plasticizers that contain organically bound bromine or chlorine.

Note: The requirement applies to plastic parts in all assemblies and sub-assemblies. Exempted are *printed wiring board laminates*, electronic components and all kinds of cable insulation.

2. The All-in-one PC shall not contain PBB, PBDE and HBCDD.

Note: The requirements apply to components, parts and raw materials in all assemblies and sub-assemblies of the product e.g. batteries, paint, surface treatment, plastics and electronic components.

The following information shall be submitted to an approved verifier:

A written guarantee that the above mandate is fulfilled. The guarantee shall be signed by the responsible person at the applicant company.

The following information shall be submitted with the application to TCO Development:

A copy of a verification report from a verifier approved by TCO Development.

We hereby guarantee that the above mandate is fulfilled.

.....
Product brand name and model name

.....
Signature

.....
Name and title in block capitals

.....
Date

.....
Company

A.6.4.3 Non-halogenated substances

Background

The purpose of this mandate is to ensure that the phase out of halogenated flame retardants not risk a shift towards substances with other known hazardous effects.

The mandate focuses on 14 hazardous statements. All substances relevant for the IT industry that have been assigned a hazardous statement and where there are less hazardous commercially available alternatives will be restricted from TCO Certified products. The list of these substances is evaluated and revised in each new version of the criteria document.

To date in this version, only harmonized substances found on the European chemical Substance Information System (ESIS) at: <http://esis.jrc.ec.europa.eu/> have been restricted. In the future version of the criteria document TCO Development have the ambition to also restrict substances that are not at this time harmonized. An example of such not yet harmonized substances may be found in B.6.4.3.

Definitions

Plastic parts are parts made mainly of plastics, e.g. the housing. Parts containing other materials in any significant amounts, e.g. cables with metal conductors, are not included in the definition.

Printed wiring board laminate is a printed board that provides point-to-point connections but not printed components in a predetermined configuration on a common base.

Hazardous statements (Risk phrases) according to EU Regulation 1272/2008 (EU Directive 67/548/EEC)

- H340 (R46) (may cause heritable genetic damage)
- H341 (R68) (suspected of causing genetic defects)
- H350 (R45) (may cause cancer)
- H350i (R49) (may cause cancer by inhalation)
- H351 (R40) (limited evidence of a carcinogenic effect)
- H360F (R60) (may impair fertility)
- H360D (R61) (may cause harm to the unborn child)
- H361d (R63) (suspected of damaging the unborn child)
- H361f (R62) (suspected of damaging fertility)
- H362 (R64) (may cause harm to breast-fed children)
- H372 (R48/25/24/23) (danger of serious damage by prolonged exposure)
- H373 (R48/20/21/22) (may cause damage to organs through prolonged exposure)
- H400 and H410 (R50/R53) (very toxic to aquatic organisms / may cause long-term adverse effects in the aquatic environment)
- H411 (R51/53) (Toxic to aquatic life with long-lasting effects)

Applicability

All-in-one PCs.

Clarification

B.6.4.3

References

65 and 66.

Mandate A.6.4.3:

The following non halogenated flame retardants shall not be used in plastic parts that weigh more than 25 grams since they are *harmonized* and covered by one or more of the hazardous statements restricted for TCO Certified products:

- Antimony(III) oxide (Sb₂O₃), CAS: 1309-64-4
- Tri-o-cresyl phosphate, CAS: 78-30-8

Exempted are *printed wiring board laminates*, electronic components and all kinds of cable insulation.

The following information shall be submitted to an approved verifier:

A written guarantee that the above mandate is fulfilled. The guarantee shall be signed by the responsible person at the applicant company.

The following information shall be submitted with the application to TCO Development:

A copy of a verification report from a verifier approved by TCO Development.

We hereby guarantee that the above mandate is fulfilled.

.....

Product brand name and model name

.....
Signature

.....
Name and title in block capitals

.....
Date

.....
Company

A.6.4.4 Plastics with chlorine and bromine as part of the polymer

Background

PVC is by far the most common halogen containing plastic. There are however other plastics that contain chlorine or bromine in the plastic itself. As the requirement concerning permissible flame retardants tightens, the risk increases that halogenated plastics will become more common. TCO Development sees a future environmental risk with such a development.

PVC is a much-debated plastic that can pose environmental problems in most parts of its life cycle. The magnitude of the environmental problems relating to PVC differs depending on the environmental status of a particular manufacturing facility and the uses of additives. At present there are very limited possibilities to distinguish between harmful and less harmful production facilities for PVC.

Definitions

Plastic parts are parts made mainly of plastics, e.g. the housing. Parts containing other materials in any significant amounts, e.g. cables with metal conductors, are not included in the definition.

Printed wiring board laminate is a printed board that provides point-to-point connections but not printed components in a predetermined configuration on a common base.

Applicability

All-in-one PCs.

Clarification

B.6.4.4

References

63 and 67.

Mandate A.6.4.4:

Plastic parts in the All-in-one PC weighing more than 25 grams shall not contain chlorine or bromine as a part of the polymer.

Note that *printed wiring board laminates*, and all kinds of internal and external cable insulation are not considered to be part of *plastic parts* and are therefore not included in the mandate.

The following information shall be submitted to an approved verifier:

A written guarantee that the above mandate is fulfilled. The guarantee shall be signed by the responsible person at the applicant company.

The following information shall be submitted with the application to TCO Development:

A copy of a verification report from a verifier approved by TCO Development.

We hereby guarantee that the above mandate is fulfilled.

.....
Product brand name and model name

.....
Signature

.....
Name and title in block capitals

.....
Date

.....
Company

A.6.4.5 Information regarding plastics, flame retarding agents and plasticizers

Background

This requirement is intended to give information about the plastics and flame retarding agents in the product to be reviewed for compliance with the environment requirements in this criteria document.

Definitions

Plastic parts are parts made mainly of plastics, e.g. the housing. Parts containing other materials in any significant amounts, e.g. cables with metal conductors, are not included in the definition.

Printed wiring board laminate is a printed board that provides point-to-point connections but not printed components in a predetermined configuration on a common base.

Applicability

All-in-one PCs.

Clarification

B.6.4.5

References

64 and 68.

Mandate A.6.4.5:

The material specifications shall be provided for *plastic parts* and *printed wiring board laminates* weighing more than 25 grams. Plasticizers or flame retardants that have concentrations above 1% by weight in the plastic part shall be stated, in accordance with ISO 1043-3 or ISO 1043-4.

The following information shall be submitted to an approved verifier:

The table below shall be completed and the guarantee signed by the responsible person at the applicant company.

Manufacturers of plastic materials who consider such information confidential may submit the information to a verifier approved by TCO Development.

The following information shall be submitted with the application to TCO Development:

A copy of a verification report from a verifier approved by TCO Development.

Note: The table below is only symbolic; please provide your answers on the appendix: Material Specifications

Plastic part and PWB name	Weight in grams	Type of plastic	Plastic manufacturer name	Plastic model name	Flame retardant/ plasticizer type	Flame retardant/plasticizer CAS number*)	Plastic label code **)

*) Chemical Abstract Service number www.cas.org

**) Labelling according to ISO 11469

We hereby guarantee that the above mandate is fulfilled.

.....
Product brand name and model name

.....
Signature

.....
Name and title in block capitals

.....
Date

.....
Company

A.6.6 Preparation for Recycling

A.6.6.1 Material coding of plastics

Background

Recycling of used electronic products is an important environmental issue. Material recycling and reuse are the best options from an environmental point of view. With material coding there is a better possibility for plastics to be recycled and used in new IT equipment.

Definitions

Plastic parts are parts made mainly of plastics, e.g. the housing. Parts containing other materials in any significant amounts, e.g. cables with metal conductors, are not included in the definition.

Printed wiring board laminate is a printed board that provides point-to-point connections but not printed components in a predetermined configuration on a common base.

Applicability

All-in-one PCs.

Clarification

B.6.6.1

References

65, 68 and 69.

Mandate A.6.6.1:

Plastic parts weighing more than 25 grams shall be material coded in accordance with ISO 11469 and ISO 1043-1, -2, -3, -4. Such parts shall be listed in the table at Section A.6.4.5.

Exempted are *printed wiring board laminates*.

The following information shall be submitted to an approved verifier:

A written guarantee that the above mandate is fulfilled. The guarantee shall be signed by the responsible person at the applicant company.

The following information shall be submitted with the application to TCO Development:

A copy of a verification report from a verifier approved by TCO Development.

We hereby guarantee that the above mandate is fulfilled.

.....
Product brand name and model name

.....
Signature

.....
Name and title in block capitals

.....
Date

.....
Company

A 6.6.2 Variety of plastics

Background

Recycling of used electronic products is an important environmental issue. Material recycling and reuse are the best options from an environmental point of view. Therefore TCO Development presents requirements that facilitate material recycling.

Applicability

All-in-one PCs.

Clarification

B.6.6.2

Definitions

Types of *plastic material* (using the abbreviation terms, symbols and concepts for plastics in ISO 1043 Part 1, 2, 3, and 4) are:

- Basic polymers
- Mixtures of polymers
- Basic polymers with flame retardants
- Mixtures of polymers with flame retardants

Product units are separate groups of the whole product:

- Display case and foot (one product unit)
- LCD panel in FPDs (one product unit)

References

68 and 69.

Mandate A.6.6.2:

Each *product unit* shall have no more than two different types of *plastic materials* for parts weighing more than 100 grams.

The light guide in FPD panels and Printed Wiring Board laminates are exempted.

The following information shall be submitted to an approved verifier:

A written guarantee that the above mandate is fulfilled. The guarantee shall be signed by a responsible person at the applicant company.

The following information shall be submitted with the application to TCO Development:

A copy of a verification report from a verifier approved by TCO Development.

We hereby guarantee that the above mandate is fulfilled.

.....
Product brand name and model name

.....
Signature

.....
Name and title in block capitals

.....
Date

.....
Company

A.6.6.3 Moulded-in metal parts and metallization of plastic housing

Background

Recycling of used electronic products is an important environmental issue. Material recycling and reuse are the best options from an environmental point of view. Therefore TCO Development presents requirements that facilitate material recycling.

Definition

Metallization is a surface deposition process whereby a metallic layer is applied to the surface of a completed shaped plastic part. Examples of metallization processes are chemical coating and ion vapour deposition.

In-Mould Insert Moulding is the process by which a metal insert is incorporated into the plastic during the moulding stage, making it extremely difficult to separate the metal from the plastic by using standard tools.

Applicability

All-in-one PCs.

Clarification

B.6.6.3

Mandate A.6.6.3:

1. There shall be no internal or external *metallization* of the All-in-one PC outer plastic casing.
2. In-Mould Insert Moulding or glued metal parts are not accepted.

The following information shall be submitted to an approved verifier:

A written guarantee that the above mandate is fulfilled. The guarantee shall be signed by the responsible person at the applicant company.

The following information shall be submitted with the application to TCO Development:

A copy of a verification report from a verifier approved by TCO Development.

We hereby guarantee that the above mandate is fulfilled.

.....
Product brand name and model name

.....
Signature

.....
Name and title in block capitals

.....
Date

.....
Company

A.6.6.4 Preparation for recycling - Mercury lamps

Background

During the dismantling and recycling of flat panel displays, lamps containing mercury present one of the greatest environmental problems. By setting the requirement that the lamps must be easily detachable and dealt with separately, Mercury can be handled in an environmental secure way and the process of material recycling of the rest of the display is facilitated.

Applicability

All-in-one PC displays which contain mercury lamps for background lighting systems.

Clarification

B.6.6.4

Mandate A.6.6.4:
Connections to be separated during the disassembly of All-in-one PC must be easy to take apart in order to not damage the mercury lamps. This means that gluing and welding must not be used to bond parts of the casing and complicate removal of the lamps.

The following information shall be submitted to an approved verifier:
A written guarantee that the above mandate is fulfilled together with an adequate description of the method by means of which the lamps shall be removed. The description shall be signed by the responsible person at the applicant company.

The following information shall be submitted with the application to TCO Development:
A copy of a verification report from a verifier approved by TCO Development.

We hereby guarantee that the above mandate is fulfilled.

.....
 Product brand name and model name

.....
 Signature

.....
 Name and title in block capitals

.....
 Date

.....
 Company

A.6.6.5 Take back system

Background

The amount of electronic waste in the world today is enormous and a growing environmental problem. It is important that manufacturers provide mechanisms to take back their equipment at end-of-life under the principle of individual producer responsibility wherein each producer must be financially responsible for managing its own brand products at end-of-life. Currently much electronic waste is being exported to developing countries where it is managed unsustainably and disproportionately burdens developing countries with this global environmental burden. The Basel Convention and its decisions govern the export of many types of electronic waste. However not all countries have properly implemented these decisions. With this mandate TCO Development aims to put more influence into spreading better electronic waste management practice to more countries.

Definition

Brand owner: The company or organization owning or controlling the Brand Name.

Brand Name: The name or sign, including but not limited to a trademark or company name, used to identify, amongst users and customers, the manufacturer or seller of a product.

Take back system is a system that makes sure that the customer can return used products to be recycled. The system can be with or without a fee.

Environmentally acceptable recycling methods are:

- Product and component reuse
- Material recycling with secured handling of hazardous chemicals and heavy metals
- Pollution-controlled energy recovery of parts of the product

Applicability

All-in-one PCs.

Clarification

B.6.6.5

References

70.

A.6.7 Product packaging

A.6.7.1 Hazardous substances in product packaging

Background

Packaging constitutes a well-known environmental problem and is regulated in many countries worldwide. Packaging material has a short lifetime and generates large volumes of waste.

There are three main areas of concern, content of hazardous substances, use of resources and transport volume.

Applicability

All packaging material.

Definition

Brand owner: The company or organization owning or controlling the Brand Name.

Brand Name: The name or sign, including but not limited to a trademark or company name, used to identify, amongst users and customers, the manufacturer or seller of a product.

Clarification

B.6.7.1

References

71.

Mandate A.6.7.1:

The packaging material shall not contain lead (Pb), cadmium (Cd), mercury (Hg) or hexavalent chromium (Cr6).

Plastic packaging material shall not contain organically bound halogens.

The following information shall be submitted to an approved verifier:

A written guarantee that the mandate above is fulfilled. The guarantee shall be signed by the responsible person at the *brand owner* company.

The following information shall be submitted with the application to TCO Development:

A copy of a verification report from a verifier approved by TCO Development.

We hereby guarantee that the above mandate is fulfilled.

..... Product brand name Model name(s) or "All products"
..... Signature Name and title in block capitals
..... Date (Declaration valid 1 year from date) Brand Owner Company

A.6.7.2 Preparation for recycling of product packaging material

Background

Packaging constitutes a well known environmental problem and is regulated in many countries worldwide. Packaging material has a short lifetime and generates large volumes of waste.

There are three main areas of concern, content of hazardous substances, use of resources and transport volume.

Applicability

All packaging material.

Definition

Brand owner: The company or organization owning or controlling the Brand Name.
Brand Name: The name or sign, including but not limited to a trademark or company name, used to identify, amongst users and customers, the manufacturer or seller of a product.

Mandate A.6.7.2:

Non-reusable packaging components weighing more than 25 grams shall be possible to separate into single material types without the use of tools.

Exempted is reusable packaging.

The following information shall be submitted to an approved verifier:

A written guarantee that the mandate above is fulfilled. The guarantee shall be signed by the responsible person at the *brand owner* company.

The following information shall be submitted with the application to TCO Development:

A copy of a verification report from a verifier approved by TCO Development.

We hereby guarantee that the above mandate is fulfilled.

..... Product brand name Model name(s) or "All products"
..... Signature Name and title in block capitals
..... Date (Declaration valid 1 year from date) Brand Owner Company

A.7 Corporate Social Responsibility

A.7.1 Corporate Social Responsibility

Background

Expectations for Corporate Social Responsibility (CSR) performance are increasing from customers and institutions. As part of the development towards being a true sustainability label, TCO Development is now introducing an extended mandate regarding supply chain responsibility.

TCO Development is supporting the OECD Guidelines for Multinational Enterprises ISO 26000 as references for working with social responsibility.

The CSR component of the TCO standard focuses on working conditions in the production of the TCO certified products.

TCO Development is primarily verifying the Brand owner's procedures for promoting legal and human labour standards in the supply chain as specified in the mandate but reserves the right to conduct supplier audits at production facilities. Also, the Brand owner should demonstrate commitment to corporate social responsibility.

Definitions

Brand owner: The company or organization owning or controlling the Brand Name.

Brand Name: The name or sign, including but not limited to a trademark or company name, used to identify, amongst users and customers, the manufacturer or seller of a Product.

1st tier production facility: Manufacturing plant where the final assembly of the TCO certified product is taking place.

Applicability

The Brand owner.

Clarification

B.7.1.1 – B.7.1.6

References

57, 58 and 59

Mandate A.7.1:

The *Brand owner* shall demonstrate the TCO Certified product is manufactured under working practices that promote good labour relations and working conditions by proving accordance with the following:

- ILO:s eight core conventions 29, 87, 98, 100, 105, 111, 138 and 182.
- UN Convention on the Rights of the Child, Article 32.
- the health and safety legislation in force in the country of manufacture, and
- the labour law, including rules on minimum wage and the social security protection in the manufacturing country.

In situations where the right to freedom of association and collective bargaining are restricted under law, workers shall be permitted to freely elect their own representatives. Reasonable effort shall be made to ensure that the requirements of this standard are being met by suppliers and subcontractors throughout the supply chain.

The brand owner accepts that TCO Development may conduct/commission on-site inspections and receive full audit reports as part of the application to verify that the *Brand owner* is fulfilling its obligations according to this Mandate. For the social audit reports and on-site-inspections, the requirement is limited to the *1st tier production facility*.

The following information shall be submitted to a verifier approved by TCO Development:

1. The requirement is fulfilled by one of the following options (a-d):
 - a) The *Brand owner* is a member of EICC and provides documented proof of third party audits conducted at production facilities of TCO certified products.
 - b) The *Brand owner* is SA8000 certified or carrying out the production at SA8000 certified facilities and provides documented proof of third party audits conducted at production facilities of TCO certified products.
 - c) The *Brand owner* shall complete the Self-documentation according to a questionnaire provided by TCO Development and provide documented proof of third party audits conducted at production facilities of TCO certified products.
 - d) The *Brand owner* applies for a 12 month grace period by submitting a signed declaration stating which option above (a, b or c) shall be implemented by them and an estimation of when all the necessary documented proof will be available.
2. A written guarantee that the above mandate is fulfilled. The guarantee shall be signed by the responsible person at the *Brand owner* company.

The following information shall be submitted with the application to TCO Development: A copy of a verification report from a verifier approved by TCO Development.

- Option (to be verified):
- 1. Member of EICC
 - 2. SA8000 certified
 - 3. Self-documentation/TCO Development questionnaire
 - 4. 12 months grace period

We hereby guarantee that the above mandate is fulfilled.

.....
 Product brand name Model name(s) or "All products"

.....
 Signature Name and title in block capitals

.....
 Date (Declaration valid 1 year from date) Brand Owner Company

A.7.2 Senior Management Representative

Background

It is extremely beneficial to both parties that an open and transparent dialogue between TCO Development and Brand owner exist for the monitoring of the criteria or when issues concerning working conditions at production facilities require clarification. A contact person responsible for the organization's efforts to enforce the CSR requirements needs to be consistently available for dialogue with TCO Development throughout the certification period.

Definitions

Brand owner: The company or organization owning or controlling the *Brand Name*.

Brand Name: The name or sign, including but not limited to a trademark or company name, used to identify, amongst users and customers, the manufacturer or seller of a Product.

Clarification

B.7.2

Mandate A.7.2:

The Brand owner shall have an appointed senior management representative who, irrespective of other responsibilities, shall ensure that the requirements of this mandate are met. The contact details of this person shall be submitted and the person shall be available for dialogue in English with TCO development throughout the certification period.

The following information shall be submitted to a verifier approved by TCO Development:

1. Name, Title, Telephone Number and Email Address of the senior management representative available for dialogue in English with TCO Development around CSR issues.
2. A written guarantee that the above mandate is fulfilled. The guarantee shall be signed by the responsible person at the Brand owner company

The following information shall be submitted with the application to TCO Development:

A copy of a verification report from a verifier approved by TCO Development.

We hereby guarantee that the above mandate is fulfilled.

..... Product brand name Model name(s) or "All products"
..... Signature Name and title in block capitals
..... Date (Declaration valid 1 year from date) Brand Owner Company

R References

International standard organisations referred to in the reference list below and their home pages.

- ASTM, American Society for Testing and Materials, <http://www.astm.org/>
 - CIE, Commission Internationale de l'Eclairage, International Commission on Illumination, www.cie.co.at/cie/
 - DIN, Deutsches Institut für Normung e. V., www2.din.de
 - EBU, European Broadcasting Union, http://www.ebu.ch/tech_info.html
 - IEC, International Electrotechnical Commission, www.iec.ch
 - ISO, International Organization for Standardization, <http://www.iso.org/>
 - ITU, International Telecommunication Union www.itu.int/home/index.html
 - SMPTE, Society of Motion Picture Television Engineers, www.smpste.org
 - VESA, Video Electronics Standards Association, www.vesa.org
1. CIE Publication 69 (1987), Methods of characterizing illuminance meters and luminance meters: performance characteristics and specifications.
 2. Flat Panel Display Measurements Standard, (FPDM), Version 2.0, VESA - Video Electronics Standards Association Display Metrology Committee. June 1, 2001, CA 95035, Milpitas.
 3. <http://www.w3.org/Graphics/Color/sRGB.html>
 4. SMPTE RP 145-1994: SMPTE C Color Monitor Colorimetry
 5. ASTM gloss standard D523.
 6. ISO2813:1994.
 7. DIN 67 530.
 8. CIE Publication 15.2 (1986), Colorimetry, p. 11, p.27-28 and p. 53-54, table 1.3).
 9. IEC 61966-2-1 (1999-10) Multimedia systems and equipment - Colour measurement and management - Part 2-1: Colour management - Default RGB colour space – sRGB.
 10. ITU-R Recommendation BT.470-6: Conventional television systems.
 11. ITU-R Recommendation BT.709-5: Parameter values for the HDTV standards for production and international programme exchange
 12. E.B.U. Standard for chromaticity tolerances for studio monitors Tech. 3213-E August 1975.
 13. SMPTE 170M-1999 Television - Composite Analog Video Signal - NTSC for Studio Applications.
 14. Hunt, R.W.G. Measuring colour. 3rd edition (1998), Kingsley-Upon-Thames: Fountain Press.
 15. ISO TC130 WD 12646 p. 5 Section 4.7 Chromaticity and luminance of the white and black points and tracking.
 16. ISO 3664:1999, Viewing conditions for graphic technology and photography, p. 9 Uniformity of screen luminance.
 17. ISO 3664:1999, Viewing conditions for graphic technology and photography, p. 5, 4.2.4 Surround and backing for reflection viewing, Note 1 p. 8.

18. ISO 3664:1999. Viewing conditions for graphic technology and photography, p. 10 Monitor luminance.
19. Barten, P.G.J., (1999) Contrast sensitivity of the human eye and its effects on image quality, SPIE Optical Engineering Press
20. Barten, P.G.J., (1999) Contrast sensitivity of the human eye and its effects on image quality, SPIE Optical Engineering Press p. 105 - 106. (ISBN 0-8194-3496-5)
21. Barten, P.G.J., (1999) Contrast sensitivity of the human eye and its effects on image quality, SPIE Optical Engineering Press p. 179.
22. Barten, P.G.J., (1999) Contrast sensitivity of the human eye and its effects on image quality, SPIE Optical Engineering Press p. 179 - 181.
23. Kokoschka S. (1986). Visibility aspects of VDUs in terms of contrast and luminance. Behaviour and information technology. vol.5, No. 4, pp 309-333.
24. Schenkman, B., and Kjelldahl, L. (1999). Preferred colour temperature on a colour screen. Displays, 20, 73 - 81.
25. Roberts, A., Eng, B., (1995) "A method for the calculation of tolerances for display primary chromaticity coordinates" Research and development Department, Technical Resources, The British Broadcasting Corporation.
26. www.srgb.com
27. Wyszecki, G., Stiles, W.S., (1982) Color Science: Concepts and methods, quantitative data and formula, Second Edition, John Wiley & Sons, Inc. Chapter 7, Visual thresholds, pp 567-569.
28. Wyszecki, G., Stiles, W.S., (1982) Color Science: Concepts and methods, quantitative data and formula, Second Edition, John Wiley & Sons, Inc. Chapter 7, Visual thresholds, pp 574-575.
29. Le Grand, Y. (1957). Light, colour and vision. Chapman and Hall, pp 278-279.
30. Le Grand, Y. (1957). Light, colour and vision. Chapman and Hall.
31. Le Grand, Y. (1957). Light, colour and vision. Chapman and Hall, p. 119
32. Le Grand, Y. (1957). Light, colour and vision. Chapman and Hall, Chapter 11, Luminance difference thresholds, p. 261.
33. Le Grand, Y. (1957). Light, colour and vision. Chapman and Hall, Chapter 11, Luminance difference thresholds.
34. Le Grand, Y. (1957). Light, colour and vision. Chapman and Hall, Chapter 12, Colour difference thresholds p. 279.
35. Fairchild M. D. (1995), "Considering the surround in device-independent color imaging". www.cis.rit.edu/people/faculty/fairchild/PDFs/Bart.pdf
36. ISO 13406-2 Ergonomic requirements for work with visual displays based on flat panels - Part 2: Ergonomic requirements for flat panel displays. International Organisation of Standardisation.
37. ISO 9241-7 Ergonomic requirements for office work with visual display terminals (VDTs) - Part 7: Requirements for display with reflections. International Organisation of Standardisation.
38. ISO 9241-8 Ergonomic requirements for office work with visual display terminals (VDTs) - Part 8: Requirements for displayed colours. International Organisation of Standardisation.
39. ASF, the Swedish Environment Authority's Provisions and General Recommendations 1998:5

40. DIN 33402
41. EC Directive 90/270/EEC EU Directive 90/270/EEC Minimum safety and health requirements for work with display screen equipment.
42. ISO 11226 Ergonomics -- Evaluation of static working postures
43. ISO 13406-2 Ergonomic requirements for work with visual displays based on flat panels - Part 2: Ergonomic requirements for flat panel displays. International Organisation of Standardisation.
44. ISO 9241-3 Ergonomic requirements for office work with visual display terminals (VDTs) -- Part 3: Visual display requirements. International Organisation of Standardisation, 1992
45. ISO 9241-5 Ergonomic requirements for office work with visual display terminals (VDTs) - Part 5: Workstation layout and postural requirements. International Organisation of Standardisation.
46. Nymans, Berns, Gelin 1995, research report "Do AM-LCD monitors offer better ergonomic solutions than CRTs?"
47. Statshälsan 1990, User recommendations from the Swedish Foundation of Occupational Health for State Employees, report "Man, Monitor and Work Environment"
48. UK Department of Trade and Industry, Consumer Safety Unit, Adult data DTI/Pub 45/3k/01/00/NP
49. VESA Flat Panel Monitor, Physical Mounting Interface Standard (FPMPMI), version 2.0, Revision 3, March 1, or VESA Flat Display Mounting Interface Standard, (FDMI) Version 1 October 28, 2002 which replaces and supersedes FPMPMI.
50. EN 60950 (IEC 60950). Safety of information technology equipment including business equipment.
51. Bilissi, E., Jacobson, R. E., and Attridge, G. G (2008): "Just noticeable gamma difference and acceptability of sRGB image display on a CRT monitor, Imaging Technology Research Group, University of Westminster, Harrow, UK, The Imaging Scientist Journal Vol 56, 189-200.
52. Shimodaira, Y. et al., (1995), "Acceptable limits of gamma for a TFT-liquid crystal display on subjective evaluation of picture quality" Consumer Electronics, IEEE Transactions Volume 41, Issue 3, 550-554.
53. EN 60950-1 (IEC 60950-1). Safety of information technology equipment including business equipment.
54. EMAS EU regulation no 761/2001 concerning the voluntary participation of industrial companies in the Union's environmental control and review structure.
55. ISO 14001 Environmental management systems - Specification with guidance for use
56. -
57. TCO Certified Own Work questionnaire and assessment guidelines
58. Electronic Industry Citizenship Coalition (EICC), <http://www.eicc.info>
59. SA8000, <http://www.sa-intl.org>
60. ENERGY STAR® Program Requirements for PCs
61. International Efficiency Marking Protocol for External Power Supplies
62. EU Directive 2006/66/EC on batteries and accumulators containing certain dangerous substances

63. EU Directive 2002/95/EC on the restriction of the use of certain hazardous substances in electrical and electronic equipment
64. Regulation concerning Registration, Evaluation, Authorisation and Restriction of Chemicals (REACH), EC 1907/2006
65. EU Directive 67/548/EEC on the approximation of laws, regulations and administrative provisions relating to the classification, packaging and labelling of dangerous substances
66. EU Directive EC 1272/2008 on classification, labelling and packaging of substances and mixtures
67. The EU Green Paper "Environmental questions concerning PVC" KOM (2000) 469
68. ISO 11469:2000 Plastics - Generic identification and marking of plastics products
69. ISO 1043-1, -2, -3, -4 Plastics - Symbols and abbreviated terms
70. EU Directive 2002/96/EC on waste electrical and electronic equipment (WEEE)
71. Directive 94/62/EC on packaging and packaging waste.
72. Poynton, C. (2003), Digital video and HDTV Algorithms and interfaces, Morgan Kaufmann Publishers, An Imprint of Elsevier Science. Chapter 23 Gamma sRGB transfer function page 267 to 269. ISDN 1-55860-792-7
73. Watson, A. B., "31.1: Invited Paper: The Spatial Standard Observer: A Human Vision Model for Display Inspection", SID Symposium Digest of Technical Papers 37(1), 1312-1315 (2006)
74. Feng, X., Pan, H., and Daly, S., "Comparisons of motion-blur assessment strategies for newly emergent LCD and backlight driving technologies", Journal of the Society for Information Display 16, 981-988 (2008)
75. Tourancheau, S., Brunnström, K., Andrén, B., and Le Callet, P., "LCD motion-blur estimation using different measurement methods", Journal of the Society for Information Display 17, 239-249 (2009)
76. Humanscale 1/2/3, Niels Diffrient, Alvin R Tilley, Joan C Bardagjy. 1974
77. MOD, Defence standard 00-250. Human Factors for Designers of systems Part 3 (section 13 – The workplace)
78. ISO 7779:2010, Acoustics – Measurements of airborne noise emitted by PC and business equipment. This international standard is based on ECMA-74.
79. ISO 3741:2010, Acoustics – Determination of sound power levels of noise sources using sound pressure – Precision methods for reverberation rooms.
80. ISO 3744:2010, Acoustics – Determination of sound power levels of noise sources using sound pressure - Engineering method in an essentially free-field condition over a reflecting plane.
81. ISO 3745:2003, Acoustics – Determination of sound power levels of noise sources – Precision methods for anechoic and semi anechoic rooms.
82. ISO 11201:2010, Acoustics – Noise emitted by machinery and equipment – Measurement of emission sound pressure levels at a work station and other specified positions – Engineering method in an essentially free field over a reflecting plane.
83. ISO 9296:1998, Acoustics – Declared noise emission values of PC and business equipment.
84. Standard ECMA-74 8th edition, Measurement of Airborne Noise Emitted by Information Technology and Telecommunications Equipment.

B Test methods and clarifications

The following definitions, test conditions, requested specifications from clients, and other information apply for test methods described in this document.

Test results are valid only for the presentation form(s) and configuration(s) tested.

B.0 General test conditions

B.0.1 Definition of a test object

- Test objects covered by this document are All-in-one PCs. A PC with an integrated Flat Panel Display with fixed positions of the pixels.
- A test object with all necessary information for its operation shall be delivered to the test laboratory in test ready condition including any required accessories. All necessary information about how to operate and adjust the test object shall be provided.
- The performance of the test object shall in all aspects be fully in accordance with the performance of the final product.
- The client shall inform the test laboratory if any image enhancement software or hardware is used for the All-in-one PC, since this can arbitrarily influence the measurements, causing test laboratories to question the results.

B.0.2 Required test object information

- The client shall specify the name(s), type designation(s) and manufacturer for all different exchangeable parts of the test object.
- The client shall specify the display resolution of the All-in-one PC and the vertical and horizontal frequencies for testing.
- The client shall specify the name, type designation and manufacturer of the graphics card. This information shall be written in the test report.

B.0.3 Conditions for the equipment under test

- The All-in-one PC being tested shall be physically prepared for testing and shall be warmed up for at least 30 min or until it is stabilised. The test engineer shall not need to wait for more than 1 hour for the display to be considered stable. In this instance the engineer may cancel the test and demand a replacement sample.
- The All-in-one PC screen surface shall be clean when tested.

- The All-in-one PC shall be tested under nominal conditions of input voltage, current, etc. If sold on different markets, one setup shall be chosen by the manufacturer which shall represent the conditions of the country in where it will be sold the most.
- If the product relies on network connection to function a network connection must be established. Otherwise the All-in-one PC shall be tested without load on any peripheral interface such as USB, firewire or network hub, memory card slot, loudspeakers or any other accessory not necessary for the functionality shall be used unless otherwise stated by the test procedure.. It is not necessary that the product contain CD/DVD.

B.0.4 All-in-one PC alignment for testing

The All-in-one PC display front shall be aligned vertically with the possibility to rotate the screen $\pm 30^\circ$ around a vertical axis through the centre-point of the screen front. It shall also be possible to tilt the screen forwards and backwards $\pm 15^\circ$ around a horizontal axis through the same centre-point.

B.0.5 Instruments used for testing

All instruments used for testing of an All-in-one PC shall be of good quality and validated by a recent test certificate from a certified testing laboratory. Any necessary instrument calibration shall be done before the tests are performed. Calibrations shall be traceable to national standards.

B.0.6 Settings of the All-in-one PC

- Pivot screens shall only be measured in the usual landscape mode.
- The All-in-one PC display resolution shall be set to the native resolution
- The All-in-one PC shall be put in its factory default mode. The CCT of the default mode shall be used.
- All tests shall be performed with the All-in-one PC in the factory default mode if not stated otherwise in the test methods.
- Testing may be done with a preset instead of the default mode if the user is informed in the user manual which preset is used for TCO Certified compliance. In this case this preset shall be treated as the default mode in the standard and noted in the test report.
- All measurements shall be taken with no adjustments made between the measurements, if not specified otherwise in the test method.
- An external control unit that is not a standard part of the All-in-one PC is not allowed.

- The colour depth of the source signal shall be 24 bits (8 bits per colour channel) or more.
- In Windows/Display Properties/Settings/Advanced the Windows “Small fonts” option shall be used.
- In Windows/Display Properties/Appearance the “Windows standard” colour scheme option shall be used.
- All settings in the operating system shall be the default ones as delivered to the end user or the default as it appears directly after the installation of the operating system.
- Integrated automatic sensors and any eco-mode functions enabled by default on the display shall be disabled by the test engineer for all the tests, as long as by doing so the default CCT setting does not change.

B.0.7 Test image/test character

- All test images can be found on the home page of TCO Development, www.tcodevelopment.com.
- The default testing 12 point Arial font and 100% “zoom/magnification” shall be used. The latest version of MS Windows operating system is the default user interface, if not otherwise stated. For Macintosh PCs, Mac OS can be used during testing. The operating system most likely to be used by an end user should be used for testing.
- The default testing polarity is positive polarity (black characters on a white background).
- Another possibility is to use a testing program that shall consist of software commonly used in office and home PC work. The word processor should be able to produce the text and graphics required for the test procedures.
- All parts of the tests for a test object shall be conducted using the same font, character size, correlated colour temperature, resolution, operating system and other settings of the All-in-one PC controls etc., unless otherwise stated in the test procedure.

B.0.8 Test Image and Test Luminance setting

The test image in Figure B.0.8.1, referred to as the TCO **Certified** default test image, has an 80 % image loading. The test image shall fill the whole usable screen that represents the “full screen mode”. This image shall be used for testing unless otherwise specified in the test procedure.

If the measured display is not affected by image loading it is permitted to use alternative images (described in *procedure* below) rather than the default test image for measurement of Black level (A.2.2.3) and RGB settings (A.2.5.3). The benefit is to minimize the contribution of stray-light for some measurement equipment. In the

event that this method is chosen, pay extra attention to displays with dynamic backlight as they may be affected by the different image loading.

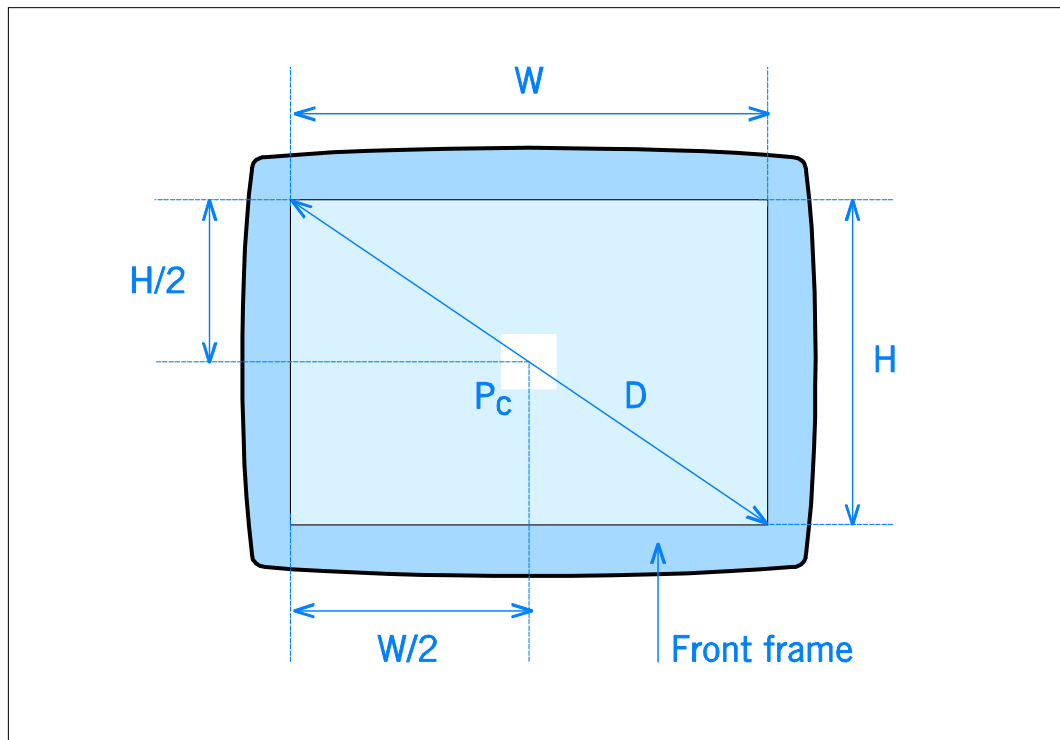

Figure B.0.8.1. The TCO Certified default test image.

Procedure:

- The background colour shall be set to RGB 204, 204, 204 (i.e. equal to 80 % image loading).
- An active white square at the centre of the screen shall be $4^\circ \times 4^\circ$ in size and have an RGB setting of 255, 255, 255. The $4^\circ \times 4^\circ$ corresponds to an area of about 34.9 mm \times 34.9 mm at a measuring distance of 500 mm or 69.8 mm \times 69.8 mm at 1 meter. For a 15" display measured at 57 cm, the $4^\circ \times 4^\circ$ corresponds to a square of 40 mm \times 40 mm.
- A permitted alternative to the $4^\circ \times 4^\circ$ test square when testing Black level and RGB settings is to increase the test square to a size that is equal to 80% of the full screen mode area. The background shall continue to be RGB 204, 204, 204.

Test Luminance setting:

- Reset the product to its default mode settings (as intended to be delivered to the end user). If the product has an automatic adjustment this can be activated once. In the default mode the luminance of the All-in-one PC display shall be ≥ 150 cd/m². If the luminance is lower, then testing can not proceed since the product does not comply with TCO certified.

B.0.9 Test report

The test results are valid only for the presentation form(s) and configuration(s) tested. If other configurations are accepted by the laboratory based on the results of the tested ones it shall be clearly specified in the test report that these configurations have not been tested.

The test report shall include the following information:

- Any changes to the test methods.
- The manufacturer, brand name, model type and serial number (if available).
- The panel brand, full panel number, if the screen is Pivot stand type and if it has a LED backlight.
- The mode(s) (i.e. horizontal and vertical scan frequency and resolution) used during the test and the aspect ratio.
- The supply voltage and frequency used during the test and whether it is a CLASS I or CLASS III type. If CLASS III the AC external power supply brand and model number shall also be stated.
- The degree of uncertainty for each given measurement result.
- The setting of contrast, brightness and CCT preset at the reset default setting.
- Photographs of the product shall be taken: Front, rear, open panel and a legible panel marking label and if applicable the external power supply with legible marking label.

B.1 General information

B.1.1 TCO Certified Document

The TCO Certified Document shall accompany the product as provided by TCO Development. No editorial changes without TCO Development's consent are accepted. The Document is available at www.tcodevelopment.com.

If the TCO Certified Document is part of a User's Manual or is provided as an electronic file then it must be separated from other text portions so that it is obvious that the TCO Document is not accountable for the content of the other texts.

The brand name owner may post the TCO Certified Document on its web site, e.g. by showing TCO Certified logos or icons that redirect the visitor by links to the TCO Certified Document

If the product that is to be TCO certified labelled is branded differently from the applicant name, the applicant company signing the guarantee shall be sure that the brand name holder agrees with the requirement.

B.2 Visual ergonomics

B.2.0 General test conditions for visual ergonomics

B.2.0.1 Basic test requirements

As described in section B.0.

For all tests, the All-in-one PC screen shall be clean.

B.2.0.2 Photometric laboratory general requirements

Photometric measurements shall be performed under darkroom conditions. This means that measurement data shall in no way be affected by direct light from sources or light reflected from interiors, equipment, clothes etc.

The laboratory shall have a routine for the control of the stray-light level at the All-in-one PC screen (see also B.2.0.6).

B.2.0.3 Power supply and test room climate requirements for testing

- AC mains voltage* 230 VAC RMS, tolerance $\leq 1\%$
- AC mains frequency* 50 Hz, tolerance $\leq 2\%$
- Test room temperature $23 \pm 3\text{ }^\circ\text{C}$
- Humidity 20-75 % RH (non condensing)

* – or other voltage and frequency combination specified by the client.

B.2.0.4 Photometric and spectrometric measurements

Several instruments are to be used when carrying out measurements for visual ergonomics. All instruments shall be recently calibrated and carry a calibration certificate from a certified testing laboratory.

The following instrument types are to be used for testing:

- **Gloss meter.** An instrument for measuring gloss as a function of the directionally selective reflecting properties of a material at angles near to and including the direction giving specular reflection.

- **Luminance meter.** A luminance meter shall have a sufficiently good V_{λ} -sensitivity (Requirements for luminance meters are covered by CIE Publication 69 (1987). Luminance meters of CIE Class L(aboratory) with a combined performance characteristic $\leq 3\%$ shall be used) and integrate luminance over a finite measuring field during a finite time. The meter shall be equipped with adjustable optics and always be focused on the measured area. The luminance meter must incorporate a sufficiently long time constant of integration in order to ensure averaging of the pulsation of the light emitted by displays. The sensitivity shall be independent of the polarization of the measured light (often referred to as f_8 error).

The luminance meter measuring field shall be one degree for all measurements, except for the micro-photometric luminance measurements, see below.

An automated instrument using collimating optics may be used for testing although the measurement area will differ somewhat from the area covered by the luminance meter. When the luminance measurement in this case is done at a shorter distance than $1.5 \times$ the screen diagonal (D) because of instrumental constraints, the laboratory shall verify that the results are equal to those done at $1.5 \times D$.

- **Micro-photometer.** Micro-photometric registration of the luminance distribution of test patterns shall be performed with an array photo detector device capable of resolving structures of ≤ 0.02 mm. A scanning device shall not be used because it is sensitive to jitter and other variations that may occur during a scanning.
- **Spectro-radiometer.** An instrument for the measurement of radiant flux as a function of wavelength shall be used. A spectro-radiometer for the measurement of light and colour is normally equipped with a microprocessor that makes it possible to obtain luminance and colour co-ordinates directly from raw measurement data. A spectro-radiometer can replace the luminance meter when suitable. The wavelength resolution shall be ≤ 4 nm for accurate colour measurements. The sensitivity shall be independent of the polarization of the measured light (often referred to as f_8 error).

B.2.0.5 Measurement distance

All measurements shall be carried out through a point, simulating the eye position of the operator, at a distance of $1.5 \times$ “diagonal of the screen” from the centre-point of the All-in-one PC display, but no less than 500 mm which could be considered as an absolute minimum viewing distance for comfortably viewing the display. The instrument shall be focused on the presented test image for all measurements.

B.2.0.6 Stray light

Stray light may cause errors which can negatively affect measurement of luminance, contrast and chromaticity coordinates. It is therefore necessary to make an evaluation of stray light influence for the different measurement procedures described in this document.

If it is verified that stray light affect the measurement result it is necessary to take actions to eliminate the source of error. Two possible ways to solve the problem are to equip the luminance meter with a well-designed screening attachment, a frustum or to use a black screening sheet at the All-in-one PC screen surface.

B.2.0.7 Overall uncertainty

The overall uncertainty of the test laboratory shall be calculated for each measurement procedure in this document and presented in the test report. The uncertainty shall be within the required levels for each criterion. All measurement uncertainties claimed for used instruments shall be referred to traceable calibration reports.

About combining overall uncertainty values during test measurements:

- Criteria are fulfilled without adding or subtracting the overall measurement uncertainty.
- Report the value shown on the instrument without adding or subtracting the overall measurement uncertainty.
- The overall measurement uncertainty of the laboratory is printed in the test report together with the reported value.
- For a Laboratory that has an overall measurement uncertainty higher than the one allowed by TCO Development for a certain criteria, then the test report for that criteria is not valid for TCO certification and the test result will not be accepted by TCO Development.

B.2.1 Image detail characteristics

B.2.1.1 Native display resolution requirement

B.2.1.1.1 Preparation of the All-in-one PC for testing

No specific preparation of the All-in-one PC is needed.

B.2.1.1.2 Equipment

Calculator and product manual or similar information about the display resolution.

B.2.1.1.3 Test method

The maximum display resolution and frequencies of the display are found in the manual or similar information from the manufacturer.

B.2.1.1.4 Test evaluation

The viewing distance is defined as $1.5 \times$ the display diagonal, but no less than 500 mm. This means that the mandate is independent of the display size and viewing distance but dependent on the display format. Only the display format needs to be known.

The minimum resolution to fulfil the criteria can be calculated for any display format in the following way:

Minimum amount of pixels in the vertical direction

Half the display height at the viewing distance expressed in degrees is:

- $\arctan(\text{width}/2/\text{viewing distance})$

The whole display height expressed in degrees is:

- $2 \times \arctan(\text{width}/2/\text{viewing distance})$

The requirement is 30 pixels/degree which gives the amount of pixels needed in the vertical direction to:

- $30 \times 2 \times \arctan(\text{width}/2/\text{viewing distance})$

Example:

For the format 5:4:3 and viewing distance 1.5 this gives the formula:

- $30 \times 2 \times \arctan(4/2/(1.5 \times 5)) = 896 \text{ pixels}$

The principle is the same in the horizontal direction.

For the most common display formats the mandates are:		
<u>Display format</u>	<u>Min amount of horizontal pixels</u>	<u>Min amount of vertical pixels</u>
5:4:3	896	679
18.36:16:9	972	557
6.4:5:4	875	706
18.87:16:10	947	601
Note: Display format is a ratio between [Diagonal : Width : Height]		
For or other aspect ratios the min display resolution shall be calculated.		

B.2.1.1.4 Overall uncertainty

Uncertainty is not applicable in this case. Product data information is sufficient.

B.2.2 Luminance characteristics

B.2.2.1 Luminance level

B.2.2.1.1 Preparation of the All-in-one PC for testing

- All necessary preparations described in B.0 and B.2.0 shall be done.
- The TCO Certified default test image with an 18-step greyscale as shown in Figure B.2.2.1 shall be used for luminance level measurement.

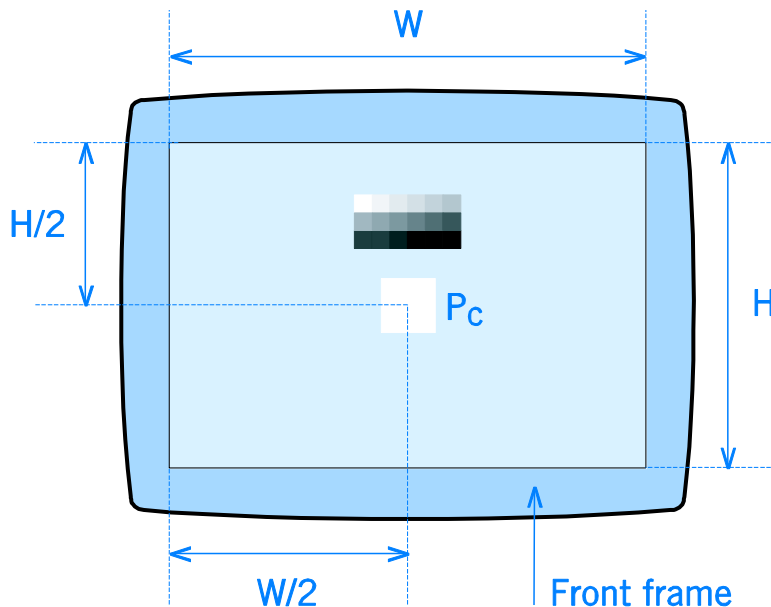

Figure B.2.2.1. TCO Certified default test image with the 18-step greyscale inserted

- The measurement position P_C shall be at the centre of a $4^\circ \times 4^\circ$ square without line borders, having an RGB setting of 255, 255, 255, and positioned at the centre of the screen. The background shall be RGB 204, 204, 204.
- Reset the display to its default setting. Check that the luminance is $\geq 150 \text{ cd/m}^2$.

The following evaluations shall be carried out orthogonally to the screen surface.

- To achieve the maximum luminance proceed as follows:
Use the TCO Certified default test image with an 18-step greyscale pattern presented on the screen. From the default setting, adjust the controls on the display to achieve as high luminance as possible with an acceptable image quality. The image quality is considered acceptable if at least 15 of the 18 greyscale steps are visible. At this maximum luminance check that the display has a luminance $\geq 200 \text{ cd/m}^2$.
- Reset the display to its default setting. From the default setting, adjust the controls on the display to achieve as low luminance as possible with an acceptable image quality. The image quality is considered acceptable if at least

15 of the 18 greyscale steps are visible. At this minimum luminance check that the display has a luminance $\leq 100 \text{ cd/m}^2$.

- If it is difficult to visually determine if 15 of the 18 greyscale steps are visible, then the display shall comply with the gamma curve criteria (A.2.2.5) in the max and min luminance setting.
- After this test is completed the display shall be put back in its default mode by pressing a reset button or similar. After each reset the display has to stabilize before other measurements are made.

B.2.2.1.2 Equipment

Luminance meter.

B.2.2.1.3 Test method

The luminance at the centre of the white test area shall be measured with the luminance meter directed orthogonally to the test area as described in B.2.0.5.

B.2.2.1.4 Test evaluation

The measured luminance is the required value. The luminance shall be reported with no decimal places.

The measured luminance, Contrast and Brightness settings for all conditions shall be noted in the test report. The preset CCT in default setting shall also be noted.

B.2.2.1.5 Overall uncertainty

$\leq \pm 10 \%$ in luminance.

See B.2.0.7.

B.2.2.2 Luminance uniformity

B.2.2.2.1 Preparation of the All-in-one PC for testing

- All necessary preparations described in B.0 and B.2.0 shall be done.
- The entire active area of the screen shall be white and the All-in-one PC colour setting shall be RGB 255, 255, 255.

B.2.2.2.2 Equipment:

Luminance meter.

B.2.2.2.3 Test method:

The luminance shall be measured orthogonally to the All-in-one PC screen plane at 9 points. The 4 corner positions (1, 3, 7 and 9) are measured 1° from the edges of the screen as shown in Figure B.2.2.2.1. The 4 side positions (2, 4, 6 and 8) are measured on the middle of the side 1° from the edge. Finally the centre position (5) is measured. This means that all measurement points have $1/2^\circ$ marginal to the edges if the measurement area of the instrument is 1° .

The luminance uniformity shall also be evaluated visually by the technician in order to find any dark or bright areas except from the 9 default positions. If a significantly bright or dark area is found these measuring points shall also be measured and used to evaluate the luminance uniformity.

The conditions for luminance measurement in the corner positions and the distribution of other measurement points are illustrated in figure B.2.2.2.1.

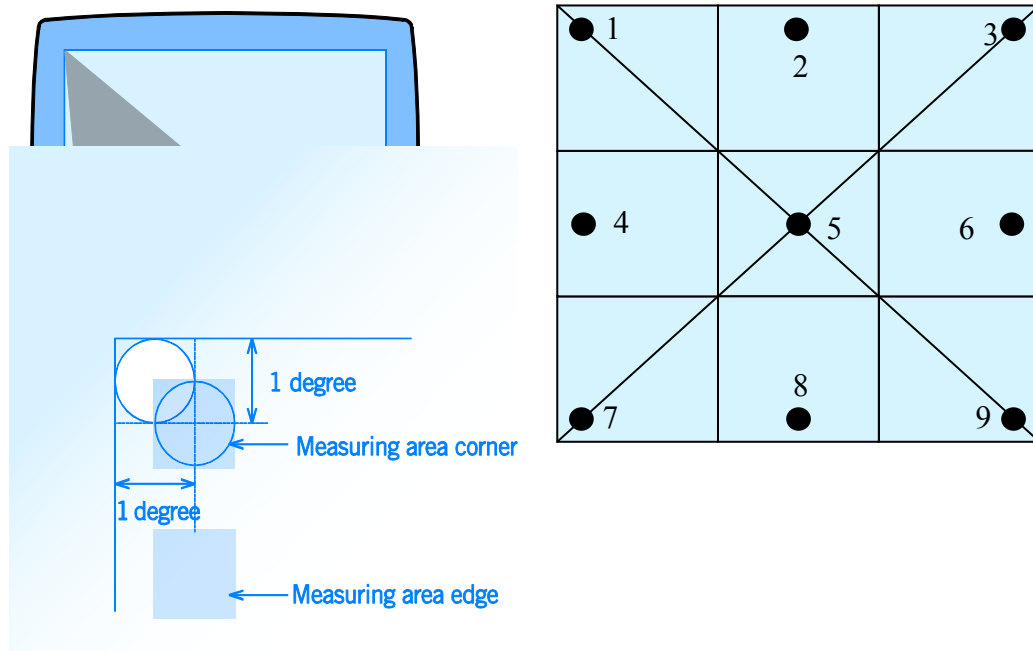

Figure B.2.2.2.1. Measurement positions for the measurement of luminance and colour uniformity.

B.2.2.2.4 Test evaluation

The luminance uniformity shall be reported as the ratio between the highest and the lowest measured luminance values.

The result shall be presented to 2 decimal places.

B.2.2.2.5 Overall uncertainty

$\leq \pm 10\%$ in luminance.

$\leq \pm 0.1$ unit in luminance uniformity.

See B.2.0.7.

B.2.2.3 Black level

B.2.2.3.1 Preparation of the All-in-one PC for testing

- All necessary preparations described in B.0 and B.2.0 shall be done.
- The TCO Certified default test image with an 18-step greyscale as shown in Figure B.2.2.1 or the alternative larger test square image also described in B.0.8 shall be used for luminance level measurement.
- The measurement position P_C shall be at the centre of the a $4^\circ \times 4^\circ$ test square without line borders, having an RGB setting of 0, 0, 0, and positioned at the centre of the screen. Alternatively for this measurement a test square that is 80% of the full screen mode may be used.

- The black level shall be tested at maximum luminance. This is considered to be $\geq 200 \text{ cd/m}^2$.
- To achieve the maximum luminance proceed as follows:
Use the TCO Certified default test image with an 18-step greyscale pattern presented on the screen. From the default setting, adjust the controls on the display to achieve as high luminance as possible with an acceptable image quality. The image quality is considered acceptable if at least 15 of the 18 greyscale steps are visible. This maximum luminance shall be $\geq 200 \text{ cd/m}^2$.
- If it is difficult to visually determine if 15 of the 18 greyscale steps are visible, then the display shall comply with the gamma curve criteria (A.2.2.5) in the max luminance setting.
- Change the colour of the white square in the test image to black (RGB: 0,0,0) and measure the luminance of the black square check that it is $\leq 2 \text{ cd/m}^2$.

B.2.2.3.2 Equipment

Luminance meter.

B.2.2.3.3 Test method

The luminance at the centre of the black test area shall be measured with the luminance meter directed orthogonally to the test area as described in B.2.0.5.

B.2.2.3.4 Test evaluation

The measured luminance is the required value. The luminance shall be reported to one decimal place.

B.2.2.3.5 Overall uncertainty

$\leq \pm 10 \%$ in luminance.

See B.2.0.7.

B.2.2.4 Luminance uniformity – angular dependence

B.2.2.4.1 Preparation for the All-in-one PC testing

- All necessary preparations described in B.0 and B.2.0 shall be done.
- Luminance values shall be measured at five different positions on the screen as shown in Figure B.2.2.4.1. Each measurement position shall consist of white RGB 255, 255, 255 squares sized $4^\circ \times 4^\circ$ without line borders.
- The background shall be RGB 204, 204, 204.
- The luminance meter shall be positioned and directed orthogonally to the screen centre-point as described in B.2.0.5.

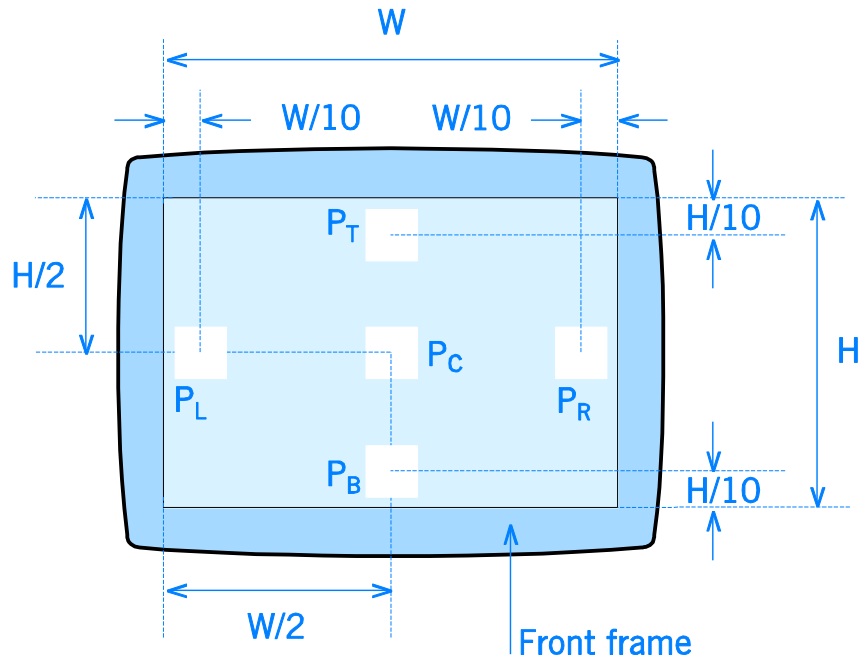

Figure B.2.2.4.1. Measurement positions for angular dependent luminance uniformity.

B.2.2.4.2 Equipment

Luminance meter.

B.2.2.4.3 Test method

1. The luminance meter shall always be directed towards a measurement point and rotated around a fixed vertical axis (or horizontal axis for the tilt measurement) through the focal point of its front lens with a distance as described in B.2.0.5.
2. In landscape mode the display shall be rotated +30 degrees around a vertical axis through the display-glass centre-point and the luminance at positions P_L and P_R , ($L_{P_L/+30/0}$ and $L_{P_R/+30/0}$ respectively) shall be recorded. See Figure B.2.2.4.2.
3. In landscape mode the display shall then be rotated -30 degrees around the vertical axis through the display-glass centre-point and the luminance at positions P_L and P_R ($L_{P_L/-30/0}$ and $L_{P_R/-30/0}$ respectively) shall be recorded. See Figure B.2.2.4.2.
4. In landscape mode the display shall then be tilted +15 degrees backwards around a horizontal axis through the display-glass centre-point and the luminance at positions P_T and P_B ($L_{P_T/0/+15}$ and $L_{P_B/0/+15}$ respectively) shall be recorded. See Figure B.2.2.4.3.
5. In landscape mode the display shall then be tilted -15 degrees forwards around a horizontal axis through the display-glass centre-point and the luminance at positions P_T and P_B ($L_{P_T/0/-15}$ and $L_{P_B/0/-15}$ respectively) shall be recorded. See Figure B.2.2.4.3.
6. The measurements to be carried out are summarised in Table B.2.2.4.1. The step numbers in the step column correspond with the test method paragraphs.

Table B.2.2.4.1.

Reference above test method step	Landscape mode	Screen rotation	Screen tilt	Measuring points			
				P _L	P _R	P _T	P _B
Step 2	Horizontal direction (turned around vertical axis)	+30°	0°	X	X		
Step 3	Horizontal direction (turned around vertical axis)	-30°	0°	X	X		
Step 4	Backwards tilt = (turned around the horizontal axis)	0°	+15°			X	X
Step 5	Forwards tilt = (turned around the horizontal axis)	0°	-15°			X	X

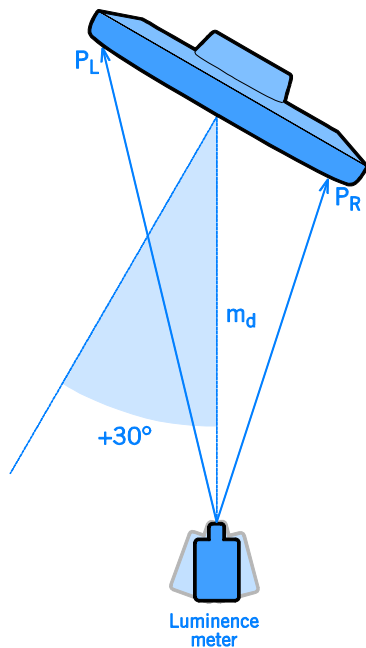

Figure B.2.2.4.2. Top view of test set-up when the All-in-one PC is rotated ± 30 degrees. The + rotation is defined clockwise.

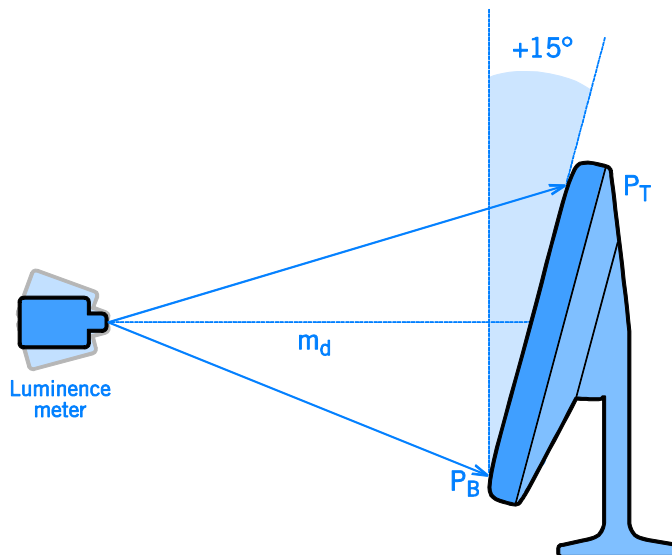

Figure B.2.2.4.3. Side view of the test set-up when the All-in-one PC is tilted $\pm 15^\circ$. The + rotation is defined as backwards.

B.2.2.3.4 Test evaluation

The luminance uniformity for angular dependence shall be calculated as follows: In landscape mode, for the horizontal direction, (turned around the vertical axis) measurement presented in Table B.2.2.4.1 (test step 2 and 3). A ratio between the two measured luminances shall be calculated. This ratio, or its inverse if it has a higher value, shall be reported as the requested L_{\max} to L_{\min} luminance uniformity in **mandate 1**. The requirement is on the mean value of the two ratios $+30^\circ$ and -30° . The result shall be presented to 2 decimal places.

In landscape mode, for the vertical direction (turned around the horizontal axis). Tilt backwards and tilt forwards $\pm 15^\circ$ test step 4 and 5. A ratio between the two measured luminances shall be calculated. This ratio, or its inverse if it has a higher value, shall be reported as the requested L_{\max} to L_{\min} luminance uniformity in **mandate 2**. The requirement is on the larger of the two ratios $+15^\circ$ and -15° . The result shall be presented to 2 decimal places.

B.2.2.4.5 Overall uncertainty

- $\leq \pm 10\%$ in luminance.
 - $\leq \pm 0.3^\circ$ in rotation angle.
 - $\leq \pm 0.1$ unit in luminance uniformity.
- See B.2.0.7.

B.2.2.5 Greyscale gamma curve

B.2.2.5.1 Preparation of the All-in-one PC testing

- All necessary preparations described in B.0 and B.2.0 shall be done.
- A TCO Certified default test image, as shown in Figure B.0.8.1, shall be used for this measurement.
- The $4^\circ \times 4^\circ$ square shall have each of the following RGB settings: R=G=B=255, 225, 195, 165, 135, 105, 75 and 45.

B.2.2.5.2 Equipment

Luminance meter.

B.2.2.5.3 Test method

Measure the luminance at the centre of the $4^\circ \times 4^\circ$ square for each greyscale setting specified above. Change the greyscale of the square for each measurement.

B.2.2.5.4 Test evaluation

The different greyscale luminance levels shall be within the max- and min levels according to the equation or the table below, where 100% means the luminance level measured for white, RGB 255, 255, 255.

Comments on the limits tolerance from the sRGB curve

A linear tolerance has been applied symmetrically around the sRGB gamma curve. However, as most displays on the market today have S-shaped gamma curves a “S-correction” has been added to the linear tolerance on the gamma level 225 and 195.

This correction is added since this is a new requirement and the industry needs time to adapt to a gamma curve which is not S-shaped. This correction has been determined based on statistics from measured displays. TCO Development may decide to remove this “S-correction” in the next version of this criteria document.

Table 2.2.5.4

Grey level	L_{sRGB}	L_{min}	L_{max}
	%	%	%
255	100	100,0	100,0
225	75	70	93
195	55	46	68
165	38	29	49
135	24	17	36
105	14	8	24
75	7	3	14
45	3	1	7

B.2.2.5.5 Overall uncertainty

$\leq \pm 10\%$ in luminance.

See B.2.0.6.

B.2.3 Luminance contrast characteristics

B.2.3.1 Luminance contrast – characters

B.2.3.1.1 Preparation of the All-in-one PC for testing

- All necessary preparations described in B.0 and B.2.0 shall be done.
- A micro-photometer for luminance measurement shall be aligned orthogonally to the All-in-one PC screen.
- The test image shall be filled with rows of the regular capital letter “H” in 12 point Arial font.

B.2.3.1.2 Equipment

A micro-luminance meter such as an array photo detector capable of measuring luminance on structures ≤ 0.02 mm. Measurement requirements are given in clause B.2.0.2.

B.2.3.1.3 Test method

- By visual evaluation of the standard test measurement position the technician shall search for and locate visual stripes, or patches, that clearly influence the contrast of characters or even parts of characters. Once the patches are visually identified as having significantly lower contrast they shall be geometrically referenced from the upper left corner of the active image and measured, see below. If one position is found that does not fulfil the mandate, there is no need to make further measurements.
- With a micro-luminance meter or a luminance scanner the luminance signal of and around a vertical stroke of a capital H of 12 point Arial font shall be measured. The optical axis of the luminance meter shall be aligned with the normal of the screen surface at the measuring point. The misalignment between the screen surface normal and the optical axis of the luminance meter shall be less than 0.3° .
- The height (h) of the measuring windows shall be $1/3$ of the actual height (H) of the character “H”. The window shall be positioned symmetrically between the horizontal stroke and the lower ending of the vertical stroke (see Figure B.2.3.1.1).

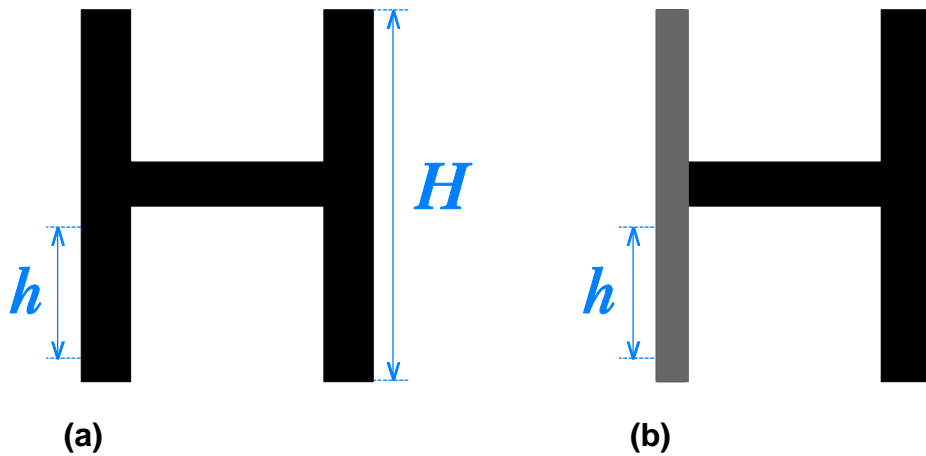

Figure B.2.3.1.1. Example of one capital “H” with (a) good contrast and one with (b) low contrast due to a paler and thinner left vertical stroke. The measuring window having height h shall be positioned symmetrically between the horizontal stroke and the lower ending of the vertical stroke of the H.

- The physical width of each measuring window or the matrix element shall be less or equal to $1/8$ of the pixel size, but not more than 0.02 mm (cf. Figure B.2.3.1.2).

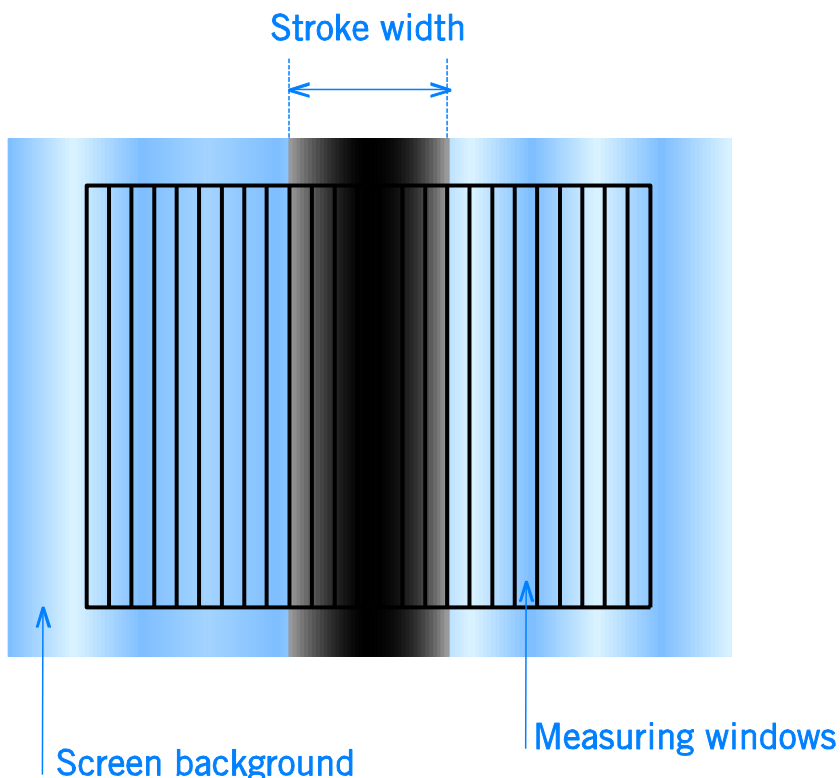

Figure B.2.3.1.2. Magnification of the vertical stroke in Figure B.2.3.1.1(a) showing a number of sampling windows.

- The basic luminance signal scanned from left to right in Figure B.2.3.1.2 could for example be as shown in Figure B.2.3.1.3.

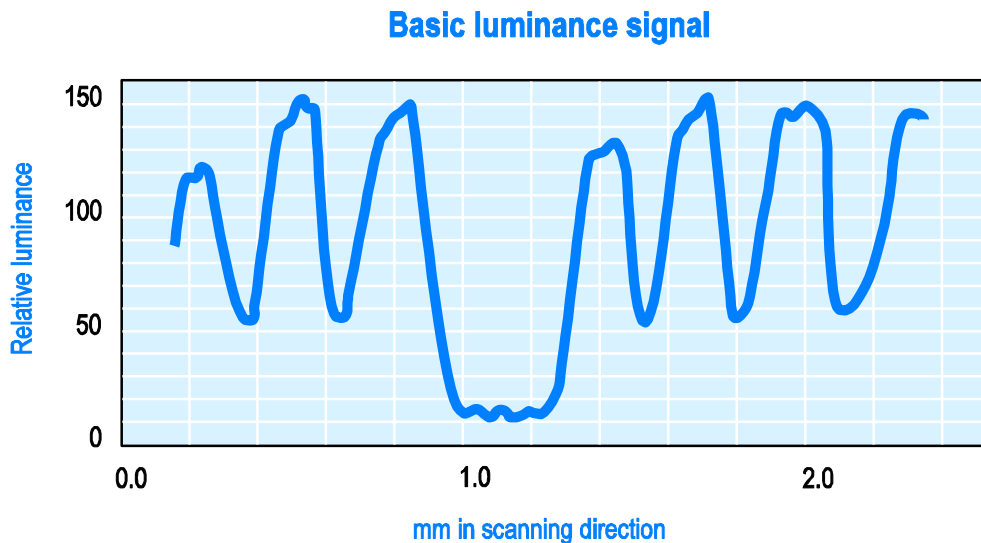

Figure B.2.3.1.3. Example of a basic luminance signal of a vertical stroke of H.

B.2.3.1.4 Test evaluation

- The basic luminance signal received from the micro-luminance meter depends on the resolution (sampling window size) of the sensor and the pixel size of the display. It is likely that the sampling window size differs between laboratories depending on photometer brand.

- The luminance contrast C shall be calculated using the formula

$$C = \frac{L_{\max} - L_{\min}}{L_{\max} + L_{\min}}$$

with the maximum and minimum luminances determined as described below.

- The photometer produces a basic luminance signal which can be filtered to a resolution of either 1 or 4 minutes of arc. These filtered signals shall be used for the calculation of C.
- To find the L_{\min} proceed as follows: The basic luminance signal shall be filtered to correspond to the 1 minute of arc resolution of the human visual system. This is equal to a sampling window size of 0.145 mm at 500 mm viewing distance. The filtering shall be done by applying a moving average to the basic input data. For example, the 1 minute of arc filtering applied to the luminance signal in Figure B.2.3.1.3 gives the signal in Figure B.2.3.1.4.

1 minute of arc filtered luminance signal used for L_{min} calculation

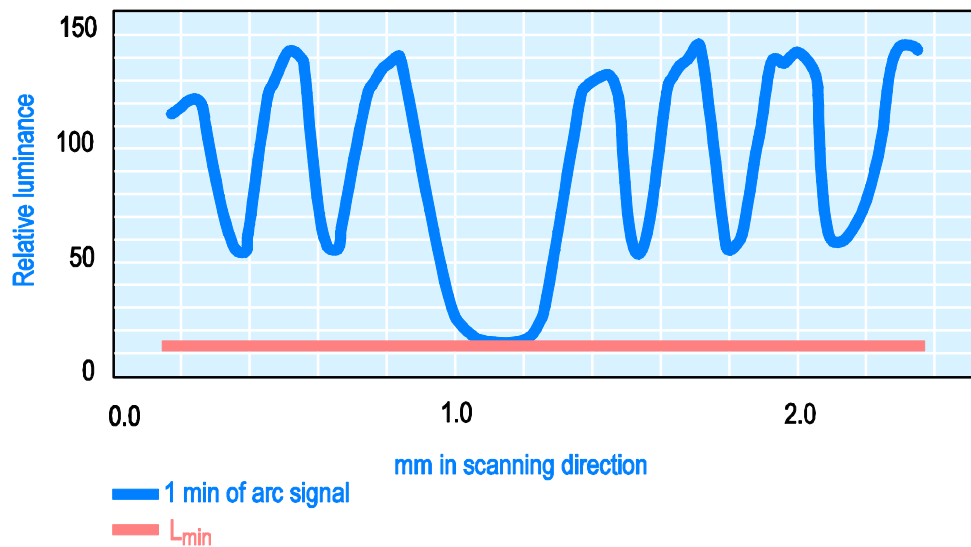

Figure B.2.3.1.4. The luminance signal filtered to 1 minute of arc and showing L_{min} .

- The lowest relative luminance in the vertical stroke in the 1 minute of arc signal is L_{min} .
(In the example of Figure B.2.3.1.4, the L_{min} value is 14 cd/m^2).
- To find the L_{max} proceed as follows: The 4 minute of arc signal filtering shall be obtained by applying a moving average to the 1 minute of arc signal. This corresponds to a more comfortable viewing condition. The filtered luminance signal is shown in Figure B.2.3.1.5.

4 minutes of arc filtered luminance signal used for L_{max} calculation

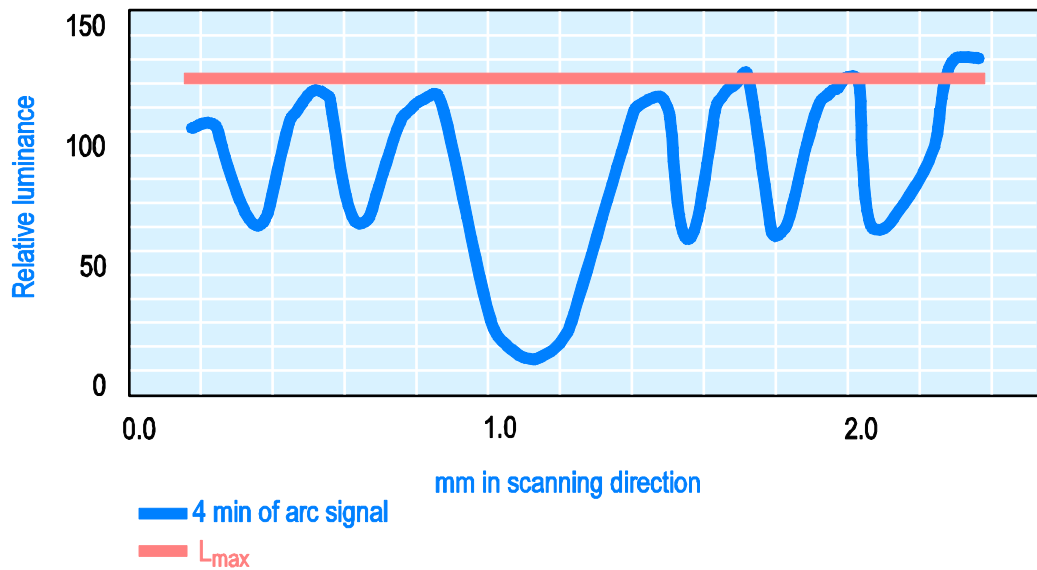

Figure B.2.3.1.5. The 1 minute of arc luminance signal filtered to 4 minutes of arc and showing L_{max} .

- The maximum luminances may be different on the two sides of the H stroke. Select the lower one as L_{max} .

(In the example of Figures B.2.3.1.4 and B.2.2.1.5 the luminance is lower on the left side than the right side and thus

$L_{max} = 127 \text{ cd/m}^2$. With $L_{min} = 14 \text{ cd/m}^2$ the contrast is $C = (127 - 14) / (127 + 14) = 0.80$).

The lowest luminance contrast found shall be reported.

The result shall be presented to 2 decimal places.

B.2.3.1.5 Overall uncertainty
 $\leq \pm 0.05$ in contrast.

See B.2.0.7.

B.2.3.2 Luminance contrast – angular dependence

B.2.3.2.1 Preparation of the All-in-one PC for testing

- All necessary preparations described in B.0 and B.2.0 shall be done.
- A TCO Certified default test image, as shown in Figure B.0.8.1, shall be used for this measurement.
- The $4^\circ \times 4^\circ$ square shall have each of the following RGB settings: (RGB 255, 255, 255) and (RGB 0, 0, 0).

B.2.3.2.2 Equipment

Luminance meter.

B.2.3.2.3 Test method

- The luminance meter shall be positioned and directed orthogonally to the screen centre-point as described in B.2.0.5.
- The All-in-one PC display shall be rotated around a vertical axis through the screen front centre, changing the azimuth angle to $+30^\circ$. The luminance of the white square L_{W+30} and the luminance when the square is black L_{B+30} at the centre shall be recorded.
- Finally the azimuth angle of the screen shall be changed to -30° and the new measurements $L_{W/-30}$ and $L_{B/-30}$ taken.

B.2.3.2.4 Test evaluation

The luminance contrast values C_{+30} and C_{-30} shall be calculated using the formula

$$C = \frac{L_W - L_B}{L_W + L_B}$$

Of C_{+30} and C_{-30} , only the lowest value shall be reported as the luminance contrast.

B.2.3.2.5 Overall uncertainty

$\leq \pm 10\%$ in luminance.

$\leq \pm 0.05$ in contrast.

See B.2.0.7.

B.2.4 Reflection characteristics

B.2.4.1 Front frame gloss

B.2.4.1.1 Preparation of the All-in-one PC for testing

- No special preparation of the All-in-one PC is needed.
- All-in-one PC frame surfaces to be tested shall be clean.
- A gloss measurement instrument needs an absolutely flat surface to function properly.
- If the front frame of the display is curved, a measurement could be made elsewhere on the housing, provided that the measured surface microstructure, texture and colour are the same as the surface of the front frame.
- If no absolutely flat test surface can be found on the display frame, the manufacturer can also supply a flat piece of material with optical properties fully equivalent to the front frame material.

B.2.4.1.2 Equipment

A gloss meter in accordance with ISO2813, ASTM D 523 or DIN 67 530 and a calibrated reference standard.

The measurement of gloss shall be made using an instrument with an incident light beam angle of 60° to the normal of the measured surface.

B.2.4.1.3 Test method

Measurement of gloss shall be made at several locations on the front frame of the display. Logos, brand names, type marks, control buttons, webcam and other small markings are excluded from the measurements and the requirements.

B.2.4.1.4 Test evaluation

The gloss results shall be presented in gloss units with no decimal places.

The highest recorded gloss value shall be reported.

B.2.4.1.5 Overall uncertainty

$\leq \pm 2$ gloss units.

See B.2.0.7.

B.2.5 Screen colour characteristics

B.2.5.1 Correlated colour temperature (CCT) variation

B.2.5.1.1 Preparation of the All-in-one PC for testing

- All necessary preparations described in B.0 and B.2.0 shall be done.
- A TCO Certified default test image, as shown in Figure B.0.8.1, shall be used for this measurement.

B.2.5.1.2 Equipment

Spectro-radiometer capable of presenting CIE u' and v' chromaticity co-ordinates with at least three decimals.

B.2.5.1.3 Test method

The spectral properties at the centre of the test square shall be measured with a spectro-radiometer.

The spectral data shall then be processed, which is normally done directly in the instrument microprocessor, to give chromaticity co-ordinates. In this case the CIE co-ordinates u' and v' are needed for the test evaluation and are often presented directly by the spectro-radiometer used.

If the client has stated more than two pre-set CCTs, preparation and testing shall be repeated for the additional CCTs.

The following rules shall apply:

- Recommended default CCTs is 6500 K, but the CCT can be anywhere between 5000K and 10000K.
- Only CCTs with exactly specified numerical values have to fulfil the requirements for Pre-set CCTs.
- CCTs lower than 5000 K shall not be tested.

B.2.5.1.4 Test evaluation

The measured u'_m and v'_m values of the screen for the pre-set CCT and the CIE reference chromaticity co-ordinates u'_{CCT} and v'_{CCT} values for the reported CCT shall be used to calculate the colour difference as follows:

$$\Delta u'v' = \sqrt{(u'_{CCT} - u'_m)^2 + (v'_{CCT} - v'_m)^2}$$

This calculation shall be done for all tested pre-set CCTs.

Most displays are delivered with two or more pre-set CCTs for a white screen. These pre-set CCTs are often one or more of the following; 9300 K, 7500 K, 6500 K, 5500 K and 5000 K. The CIE 1976 u' and v' reference chromaticity co-ordinates for the five mentioned CCTs are given in Table B.2.5.1.1.

Table B.2.5.1.1

CCT in K	u¹_{cct}	v¹_{cct}
9300	0.1888	0.4457
7500	0.1935	0.4586
6500 (sRGB)	0.1978	0.4684
5500	0.2044	0.4808
5000	0.2091	0.4882

If preset CCTs other than those given in Table B.2.5.1.1 are used in the test, u'_{CCT} and v'_{CCT} can be found by using CIE tabulated data or by using CIE formulae presented in CIE Publication 15.2 (1986), Colorimetry, p.11, p. 27-28 and p. 53-54, Table 1.3.

If the spectro-radiometer used only can produce CIE 1931 x and y chromaticity co-ordinates these can be transformed to u' and v' chromaticity co-ordinates by using the formulae in the CIE Publication 15.2 mentioned above.

The relevant CIE material – conversion formulae and tabulated data for u'_{CCT} and v'_{CCT} – can also be found on the TCO Development homepage, www.tcodevelopment.com. A PC program based on the given equations can be supplied by TCO Development.

The resulting colour difference calculation shall be presented to 3 decimal places. If the AIO PC has no Pre-set CCTs then the measured default colour temperature to be stated in the report shall be given in Kelvin (K).

B.2.5.1.5 Overall uncertainty

≤ ± 0.003 in u' and v'.

See B.2.0.7.

B.2.5.2 Colour uniformity

B.2.5.2.1 Preparation of the All-in-one PC for testing

- All necessary preparations described in B.0 and B.2.0 shall be done.
- The entire active area of the screen shall be white and the All-in-one PC colour setting shall be RGB 255, 255, 255.

B.2.5.2.2 Equipment

Spectro-radiometer with a capacity to present u' and v' co-ordinates with at least 3 decimals.

B.2.5.2.3 Test method:

The colour uniformity shall be measured orthogonally to the screen plane at 9 points. The 4 corner positions (1, 3, 7 and 9) are measured 1° from the edges of the screen as shown in Figure B.2.2.2.1. The 4 side positions (2, 4, 6 and 8) are measured on the middle of the side 1° from the edge. Finally the centre position (5) is measured. This means that all measurement points have 1/2° marginal to the edges if the measurement area of the instrument is 1°.

The colour uniformity shall also be evaluated visually by the technician in order to find those areas where the colour varies the most except from the 9 default positions.

If a significant difference is found these measuring points shall also be measured and used to evaluate the colour uniformity.

The conditions for colour measurement in the corner positions and the distribution of other measurement points are illustrated in Figure B.2.2.2.1.

B.2.5.2.4 Test evaluation

$\Delta u'v'$ according to the CIE (1976) uniform chromaticity scale diagram shall be calculated for each measured position using the formula

$$\Delta u'v' = \sqrt{(u'_A - u'_B)^2 + (v'_A - v'_B)^2}$$

Where A and B are the two points found to have the largest colour difference between them.

The largest difference in $\Delta u'v'$ value shall be reported.

The result shall be presented to 3 decimal places.

(The evaluation procedure is exemplified below)

- Make a table of colour chromaticity values for each measured position

Measurement position no.	u'	v'
1	0.190	0.447
2	0.186	0.441
3	0.186	0.437
-	-	-
-	-	-
n-1	0.185	0.434
n	0.186	0.432
Largest difference	0.005 in this example	0.015 in this example

- The largest u' difference, $\Delta u'$, is 0.005 (between 0.190 and 0.185) at measurement positions 1 and n-1.
- The largest v' difference, $\Delta v'$, is 0.015 (between 0.447 and 0.432) at measurement positions 1 and n.
- Since $\Delta v'$ (= 0.015) is much larger than $\Delta u'$ (= 0.005), the $\Delta v'$ value shall be used for the calculation of $\Delta u'v'$.
- The corresponding two pairs of u' and v' to be used for the calculation are thus the values found at position 1 and position n and thus become the values used for points A and B such that

$$u'_1 = u'_A = 0.190 \text{ and } v'_1 = v'_A = 0.447 \text{ for point A in this example}$$

and

$$u'_n = u'_B = 0.186 \text{ and } v'_n = v'_B = 0.432 \text{ for point B in this example}$$

Hence $\Delta u'v' = \sqrt{0.000016 + 0.000225} = 0.01552$, which shall be reported as 0.016.)

B.2.5.2.5 Overall uncertainty
 $\leq \pm 0.003$ in u' and v' .
See B.2.0.7.

B.2.5.3 RGB settings

B.2.5.3.1 Preparation of the All-in-one PC for testing

- All necessary preparations described in B.0 and B.2.0 shall be done.
- A TCO Certified default test image, as shown in Figure B.0.8.1, shall be used for this measurement.
- The $4^\circ \times 4^\circ$ square shall have each of the following RGB settings:
(255, 0, 0) for red,
(0, 255, 0) for green,
(0, 0, 255) for blue.

B.2.5.3.2 Equipment

Spectro-radiometer with a capacity to present u' and v' co-ordinates with at least 3 decimals.

B.2.5.3.3 Test method

The instrument shall be directed orthogonally towards the different test square centres at the measurement distance described in B.2.0.5. Measure the chromaticity co-ordinates at the centre of the $4^\circ \times 4^\circ$ square for each colour setting specified above or the alternative larger test square image (80% of the full screen mode) described in B.0.8 may be used for these measurements..
Change the colour of the square for each measurement.

B.2.5.3.4 Test evaluation

The recorded chromaticity co-ordinates u' and v' for the red, green and blue squares shall be reported.

The u' and v' shall be presented to 3 decimal places.

B.2.5.3.5 Overall uncertainty

$\leq \pm 0.003$ in u' and v' for red and green.

$\leq \pm 0.007$ in u' and v' for blue.

See B.2.0.7.

B.2.5.4 Colour uniformity – angular dependence

B.2.5.4.1 Preparation of the All-in-one PC for testing

- All necessary preparations described in B.0 and B.2.0 shall be done.
- The screen background shall be RGB 204, 204, 204.
- Chromaticity co-ordinates u' and v' shall be measured at three different positions on the screen as shown in Figure B.2.5.4.1. Each measurement position shall consist of white RGB 255, 255, 255 squares sized $4^\circ \times 4^\circ$.

- The spectro-radiometer shall be positioned and directed orthogonally to the screen centre-point as described in B.2.0.5.

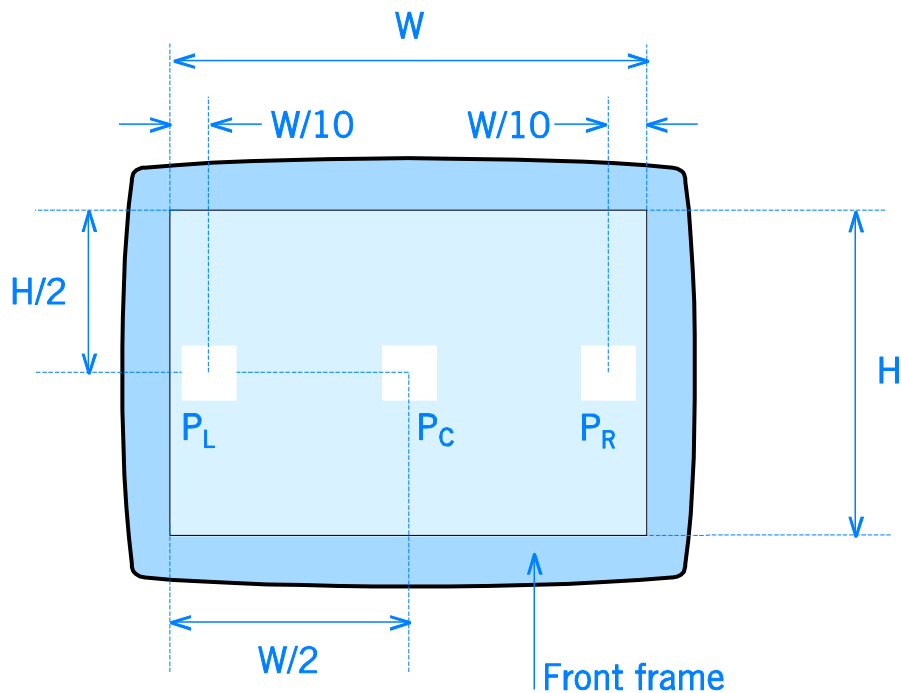

Figure B.2.5.4.1. Measurement positions for colour uniformity-angular dependence.

B.2.5.4.2 Equipment

Spectro-radiometer with a capacity to present u' and v' co-ordinates with at least 3 decimals.

B.2.5.4.3 Test method

- The spectro-radiometer shall always be directed towards a measurement point and rotated around a fixed vertical axis, (or horizontal axis for the tilt measurement) through the focal point of the front lens with a distance as described in B.2.0.5.
- The spectro-radiometer shall be turned towards positions P_L and P_R and focused. The colour co-ordinates at positions P_L and P_R ($u'_{PL/0}$, $v'_{PL/0}$ and $u'_{PR/0}$, $v'_{PR/0}$ respectively) shall be recorded.
- The screen shall then be rotated +30 degrees around a vertical axis through the screen centre-point and the chromaticity co-ordinates at positions P_L , P_R , ($u'_{PL/+30}$, $v'_{PL/+30}$ and $u'_{PR/+30}$, $v'_{PR/+30}$ respectively) shall be recorded.
- The screen shall finally be rotated -30 degrees around a vertical axis through the screen centre-point and the chromaticity co-ordinates at positions P_L , P_R , ($u'_{PL/-30}$, $v'_{PL/-30}$ and $u'_{PR/-30}$, $v'_{PR/-30}$ respectively) shall be recorded.
- Pivot screens shall only be measured in the usual landscape mode.

B.2.5.4.4 Test evaluation

$\Delta u'v'$ according to the CIE (1976) uniform chromaticity scale diagram shall be calculated for each measured position using the formula

$$\Delta u'v' = \sqrt{(u'_A - u'_B)^2 + (v'_A - v'_B)^2}$$

Where A and B are the two points found to have the largest colour difference between them.

The largest difference in $\Delta u'v'$ value shall be reported

The result shall be presented to 3 decimal places.

(The evaluation procedure is exemplified below)

- Make a table of chromaticity values for each measurement position and calculate $\Delta u'v'$ for +30° for and -30°

Measurement position no.	Example value u'	Example value v'
PL /+30	0.190	0.447
PR /+30	0.187	0.442
Difference at +30°	0.003	0.005
$\Delta u' v'$ at +30°	0.0059	
Measurement position no.	Example value u'	Example value v'
PL /-30	0.182	0.436
PR /-30	0.189	0.432
Difference at -30°	0.007	0.004
$\Delta u' v'$ at -30°	0.0081	
Largest difference $\Delta u'v'$	0.0081 in this example	

The largest calculated $\Delta u'v'$ difference is 0.0081 when the screen is rotated -30°. The test value to be reported is this value, reported to 3 decimal places, thus 0.008.

B.2.5.4.5 Overall uncertainty

$\leq \pm 10\%$ in luminance.

$\leq \pm 0.003$ units for u' and v' .

$\leq \pm 0.3^\circ$ in rotation angle.

See B.2.0.7.

B.2.5.5 Colour greyscale linearity

B.2.5.5.1 Preparation of the All-in-one PC for testing

- All necessary preparations described in B.0 and B.2.0 shall be done.
- A TCO Certified default test image, as shown in Figure B.0.8.1, shall be used for this measurement.
- The $4^\circ \times 4^\circ$ square shall have each of the following RGB settings: R=G=B= 255, 225, 195, 165, 135, 105, 75, 45.

B.2.5.5.2 Equipment

Spectro-radiometer with a capacity to present u' and v' co-ordinates with at least 3 decimals.

B.2.5.5.3 Test method

The instrument shall be directed orthogonally towards the different test square centres at the measurement distance described in B.2.0.5. Measure the chromaticity co-ordinates at the centre of the $4^\circ \times 4^\circ$ square for each greyscale step specified above. Change the greyscale of the square for each measurement.

B.2.5.5.4 Test evaluation

The evaluation procedure is exemplified below

- TCO will provide an excel spreadsheet at the TCO website www.tcodevelopmet.com which will calculate the $\Delta u' v'$ differences between all the greyscale levels according to the equation:

$$\Delta u'v' = \sqrt{(u'_A - u'_B)^2 + (v'_A - v'_B)^2}$$

- Fill in the chromaticity values of u' and v' for each measured greyscale step into the corresponding cells of the spread sheet.

The table A.2.5.5 contains coloured cells indicating difference requirements. The principle is that the darker the greyscale the more difficult it is to see a colour difference.

Examples on how to use the table: By using the column 255 (greyscale 255) and go down to line 165 (greyscale 165) you find that the maximum allowed colour difference $\Delta u'v'$ is 0.020 (orange cell). For the greyscales 225 and 75 the maximum allowed difference is 0.030 (green cell)

B.2.5.5.5 Overall uncertainty

$\leq \pm 10\%$ in luminance.

$\leq \pm 0.003$ units for u' and v' .

See B.2.0.7.

B.3 Workload ergonomics

B.3.1 Vertical tilt

It shall be possible to obtain a display tilt of at least 20° backwards from an upright position (vertical plane) in at least one of the height positions.

The measurement of 20 degrees backwards tilt starts from the vertical plane (0 degrees). Some displays may have a starting position (minimal tilt) that is already tilted backwards, for example 5 degrees, if this is the case then it is necessary to be able to tilt the display another 15 degrees to achieve the full 20 degree requirement. However the starting position (minimal tilt) shall not be more than 10 degrees backward.

We allow 1° test tolerance. This is a tolerance for test set up and not for the test sample.

B.3.2 Vertical height

The height requirement level under mandate 1 is set on documented Anthropometric data for the eye height variance for 2.5-97.5 percentile of adults. The shortest distance between eye and working surface level is taken from the 2.5 percentile of adults. The distance is from the operator's elbow (work surface height) to eye level. With a maximum height measurement set for displays that can not be height adjusted these operators will avoid the need to extend the neck backwards when scanning the screen.

The height of the population in the US and Europe has been documented in the “humanscale”

- The 2.5 percentile of the population in these regions is 145cm. According to the “humanscale” this gives an eye height of 42cm from the table top surface.
- The height measurement shall be taken with the display in normal (non-tilted) position standing directly on a flat surface and at the lowest point of height adjustment. The measurement shall be taken from the table surface to the upper edge of the active screen area – see figure B.3.2
- For the moment the criterion is based on the “humanscale” but as more relevant Anthropometrical data becomes available the criterion may be revised.

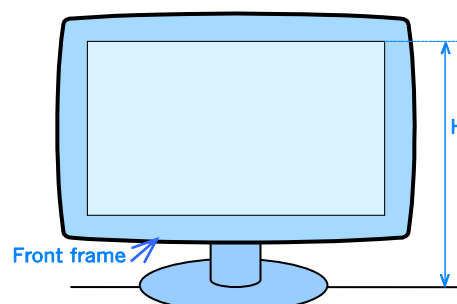

Figure B.3.2 vertical height measurement

B.4 Emissions

B.4.0 General test conditions for emissions

B.4.0.1 Basic test requirements

As described in section B.0.

For the test methods for emissions described in this document the following conditions apply:

- AC mains voltage* 230 VAC RMS, tolerance $\leq 1\%$
- AC mains frequency* 50 Hz, tolerance $\leq 2\%$
- Test room temperature $23\pm 3\text{ }^{\circ}\text{C}$
- Humidity 20-75 % RH (non condensing)

The equipment shall be connected to phase and neutral.

* – or other voltage and frequency combination specified by the client.

B.4.0.2 Conditions and set up for the test object

The tests shall be performed with the full screen size activated.

The All-in-one PC control settings shall be the same as for visual ergonomics. This means that the default setting at reset shall be used for the emission testing of alternating electric and magnetic fields the luminance at this setting shall be $\geq 150\text{ cd/m}^2$. See section B.0.8 for details concerning this setting.

The All-in-one PC shall display a full screen of capital “H” pattern in dark/black Arial letters on a luminated background (positive polarity), see section B.0.7 for details concerning this setting.

Any pivot All-in-one PC displays that can be used in both normal landscape position and portrait position (turned 90°) shall have measurements taken in both positions. The worst case shall be reported.

Any All-in-one PC equipped with a height-adjustable stand shall have measurements taken in both the lowest and highest positions. Both measurements shall be done with the measurement instrument positioned to the centre-centre point of the display surface. The worst case shall be reported.

If the All-in-one PC is connected to mains via a detachable mains cord, the measurement shall be performed with a non-shielded mains cord of normal type, (connected to earth for CLASS I device). A shielded power cord may be used if the cord is permanently attached to the All-in-one PC or external power supply. By permanently we mean that tools are necessary to remove and change the cord.

An All-in-one PC without an external power supply shall be connected to mains via the above mentioned power cable. The power cable and signal cable shall run from the points of connection on the product and then horizontally straight to a point 0.4 m behind the screen surface. The cables shall then from this point run downwards at least 1 m. – see figure B.4.0.2.1. The power and signal cables may not be placed

together unless the product is provided with an integrated cable holder. When an integrated cable holder is present it shall be used for the test to secure the cables.

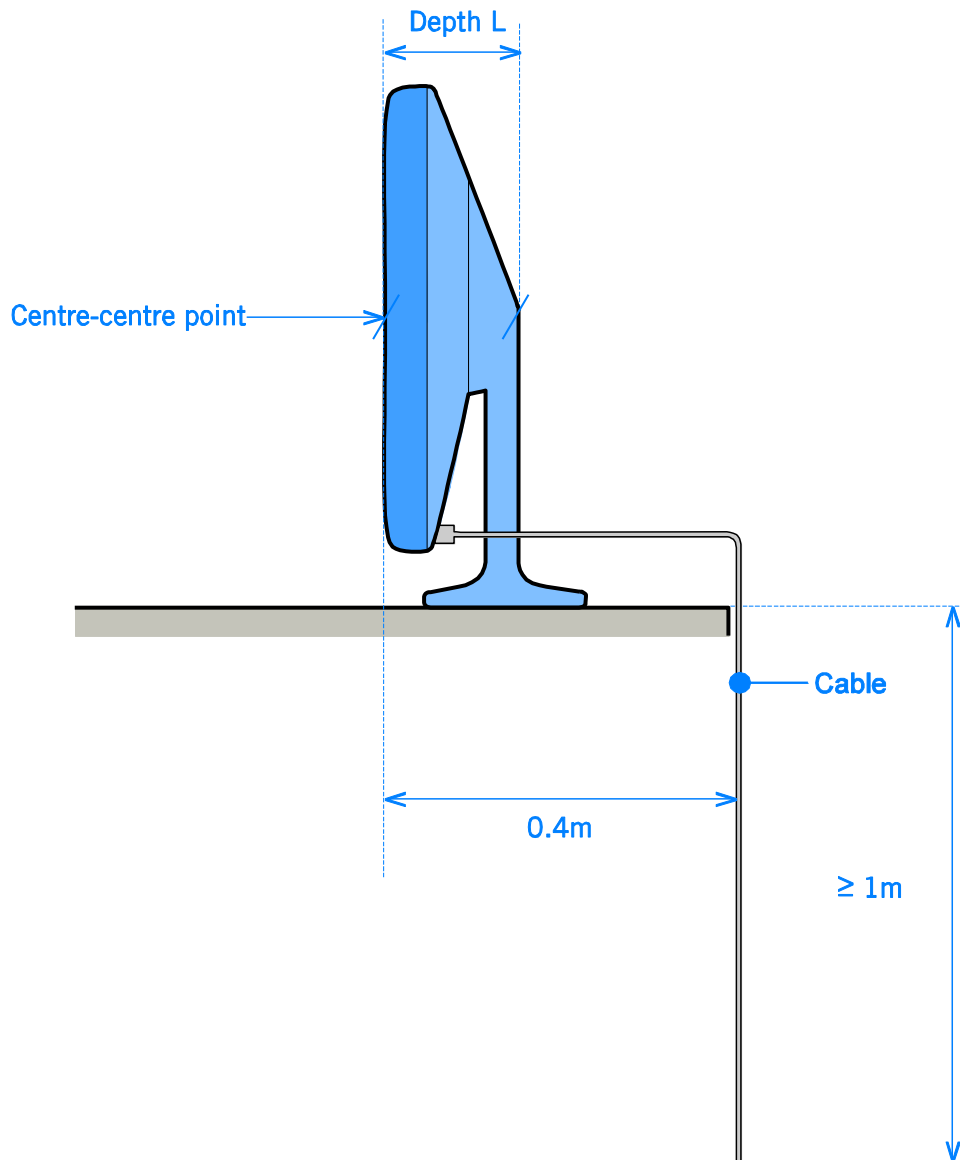

Figure B.4.0.2.1 All-in-one PC without external power supply unit.

If the All-in-one PC is provided with a fixed holder for the power and signal cables, to secure them together, then this holder is to be used during the test.

The external power supply unit, if any, will contribute to the electromagnetic fields around the All-in-one PC. Power supply units, which are connected via a primary cable to the outlet, shall be positioned centrally, directly behind the test sample, on the (turn)table, with the secondary side towards the All-in-one PC, see Figure B.4.0.2.2. The primary cable shall extend horizontally, on the (turn)table to a point 0.4 m behind the screen surface. The cable shall then, from this point run downwards at least 1 m. If the power supply can be positioned with different sides up, it shall be tested in all positions and the worst case shall be used. However, if it is obvious which side is intended to be the top side or bottom side by the placement of LED

indicator or integrated supports to stand on, it is enough to test the power supply in the one intended position.

The secondary cable of the power supply shall run the shortest distance from the point of its connection on the All-in-one PC to the secondary side of the power supply. The unused portion of the secondary cable, if any, shall be bundled together with the power supply unit. The bundle loops shall have a length equal to the longest dimension of the power supply. For supply units with dimensions less than 0.1 m, a 0.1 m bundle loop length shall be used.

For power supply units which are designed to be put directly in the outlet, without a primary cable, the secondary cable shall run vertically down to the (turn)table from the point of its connection on the All-in-one PC and then horizontally straight to a point 0.4 m behind the display surface. The cable shall then, from this point, run downwards at least 1 m.

If the product bezel has an integrated external power supply holder, this shall be used during the test and the cables placed according to the: without external power supply description above, if the product does not have an integrated cable holder. When an integrated cable holder is present then it shall be used for the test to secure the cables.

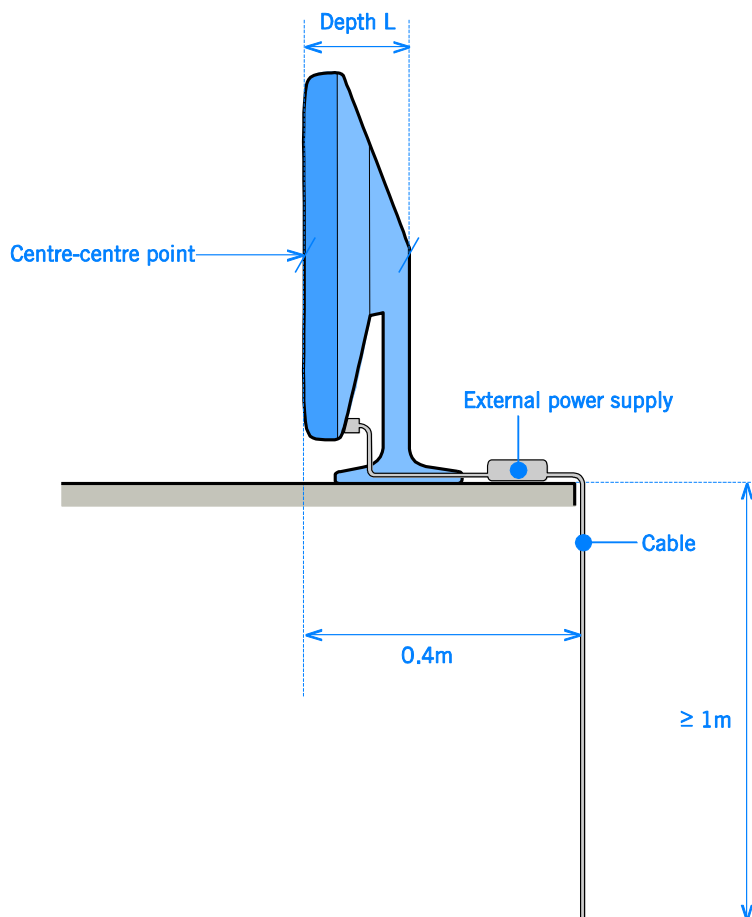

Figure B.4.0.2.2 All-in-one PC with external power supply units.

Note! For pivot All-in-one PCs and those equipped with height-adjustable stands, the cable has to be adjusted for the different positions.

For measurements of alternating magnetic fields (B.4.2) the power cable may be positioned in another way, as the cable contributes a negligible amount to the magnetic field. However external power supplies must be correctly positioned, as they may give rise to magnetic fields.

If positioning according to the above rules is not possible, then the positioning of the supply unit and cables shall be described in the test report.

If a monitor is delivered without a stand (e.g. for wall mounting) it is possible that the monitor will not pass TCO Certified requirements for emission if not a shielded power cord is used. In this special case it is allowed to use a shielded power cord if it is delivered with the All-in-one PC and it is indicated in the user manual that the product only fulfills TCO Certified criteria with this shielded cable. The power cord shall hang straight down from the monitor and if the monitor has an external ac power supply, the external power supply shall be positioned below the test sample on the floor if possible.

B.4.0.3 Emission measurement instruments

The instruments used for emission testing shall comply with the requirements and calibration procedures described below:

Alternating electric field meter

The alternating electrical field emission from the All-in-one PC under test shall be determined by measuring the displacement current passing a given surface of the measuring probe. The probe consists of a disc of double sided printed circuit board laminate with a diameter of 300 mm. On the front of the board the copper layer is removed in the annulus between radii 50 and 52 mm, see Figure B.4.0.3.1.

The copper foil surrounded by the annulus is the active measuring surface. It is connected to one input terminal of an operational amplifier, with capacitive feedback. The other input terminal of the operational amplifier, the copper ring outside the active surface, and the back of the board are connected to ground. The output voltage (U) from the probe (active surface with area (A)) is related to the incident electrical field, E, averaged over the active surface according to $U = \varepsilon \cdot E \cdot A / C$ where C is the capacitance in the feedback loop of the operational amplifier and ε is the permittivity for a vacuum.

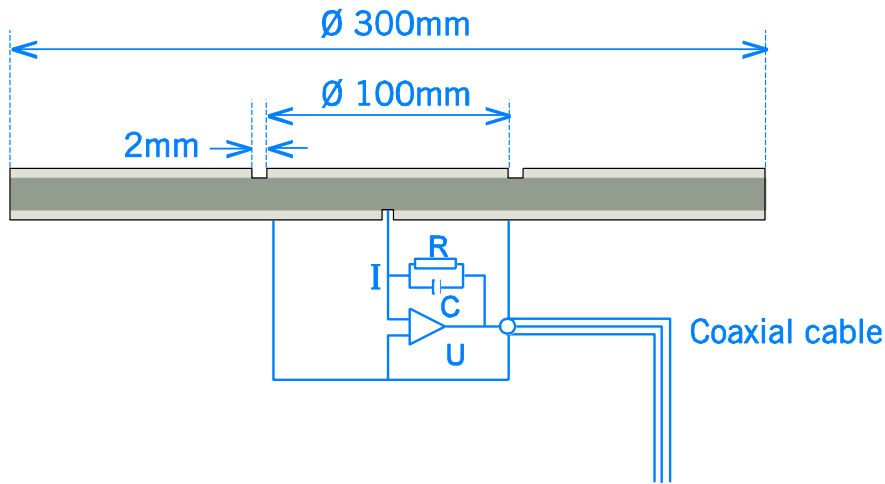

Figure B.4.0.3.1 Sketch and circuit principle of the Alternating electric field meter for alternating electrical field measurements. The feedback circuit of the operational amplifier is a capacitance C in parallel with a high value resistor R to ensure that there is no DC voltage across the plates of the capacitor C.

The specifications for the frequency response of the measuring probe are given by the calibration procedure. The signals from the probe shall be filtered by high-pass and low-pass filters. The specification of the filters is given in Table B.4.0.3.1.

Table B.4.0.3.1 Filter specifications

Frequency Band I					
Frequency	< 5 Hz	5 Hz	100 Hz	2 kHz	> 2 kHz
Attenuation	> 80 dB/decade	3 dB	0 dB	3 dB	> 40 dB/decade

Frequency Band II					
Frequency	< 2 kHz	2 kHz	30 kHz	400 kHz	> 400 kHz
Attenuation	> 80 dB/decade	3 dB	0 dB	3 dB	> 40 dB/decade

After amplification and filtering the output voltage of the measuring probe shall be used to determine the r.m.s. value of the electric field strength in both frequency bands.

The measuring time shall be sufficiently long to enable measurements with an accuracy of $\pm 5\%$ at 50/60 Hz.

The measuring system shall be capable of measuring at least down to 2.0 V/m in band I and down to 0.20 V/m in band II.

The measuring probe shall be calibrated using a parallel plate capacitor (air dielectric) consisting of the measuring probe and a metal plate of at least 300 mm diameter. The distance between the surface of the probe and the plate shall be 30 mm.

The calibration shall be performed with sinusoidal fields at the amplitudes and frequencies specified in Table B.4.0.3.2.

Table B.4.0.3.2 Calibration frequencies and amplitudes

	Frequencies	Amplitude
Band I	50, 100, 500, 1000 Hz	10, 25 V/m
Band II	15, 30, 60, 120 kHz	1.0, 2.5, 10 V/m

Recorded values at these calibration points shall be within $\pm 5\%$ of the nominal value. Due to the nature of the specified filters the deviation shall be calculated at 1 kHz from 9.5 and 22.5 V/m and at 120 kHz from 0.95, 2.4 and 9.5 V/m.

Alternating magnetic field meter in band I and band II

The magnetic field shall be measured using coil systems that shall consist of three mutually perpendicular concentric circular coils each with an area of 0.01 m². The coils may depart from a circular shape where they intersect. The minimum inner diameter shall be 110 mm and the maximum outer diameter 116 mm. The measuring coils shall not be sensitive to electric fields.

The resonance frequency of each coil appropriately connected to cables and amplifiers shall not be so low that it may influence the specified frequency response according to table B.4.0.3.1.

Amplifiers and integrating networks to make the output voltage proportional to the magnetic flux density and independent of frequency shall follow each coil. The specifications in respect of the frequency response are given in the calibration procedure.

High-pass and low-pass filters shall filter the signals from the coil systems. The specifications of the filters are given in Table B.4.0.3.1.

After amplification, integration and filtering, the signals from the three coils in each coil set shall be used as input values for calculating the r.m.s. values of the amplitudes of the magnetic flux density vectors in both frequency bands. It is permissible to calculate the r.m.s. value for each of the coil signals and use the root of the squared sum of those r.m.s. values as the test result.

The measuring time shall be sufficiently long to enable measurement with an accuracy of $\pm 5\%$ at 50/60 Hz.

The alternating magnetic field meter in band I and band II shall be capable of measuring down to at least 40 nT in band I and down to 5.0 nT in band II.

The alternating magnetic field meter in band I and band II shall be calibrated using a Helmholtz-type calibration coil as shown in the Figure B.4.0.3.2. calibration set-up. Calibration shall be performed with sinusoidal fields at the amplitudes and frequencies specified in Table B.4.0.3.3.

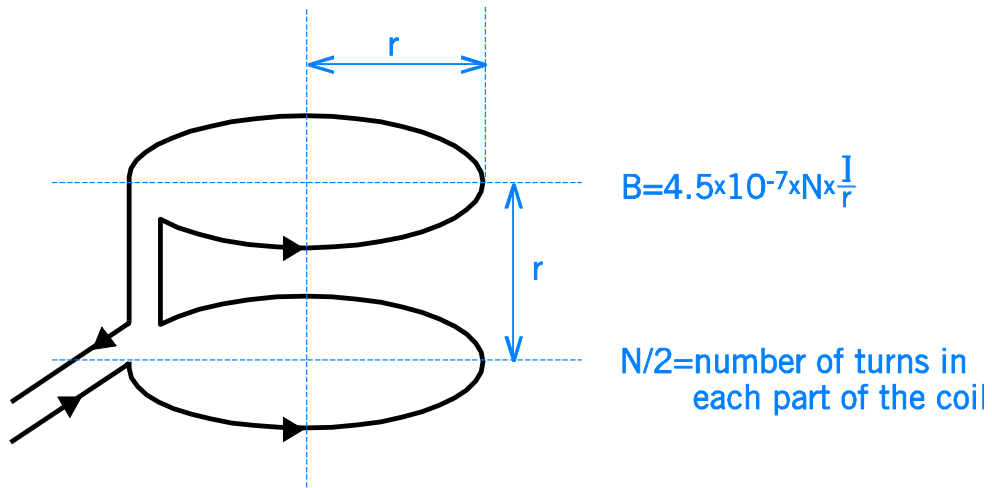

Figure B.4.0.3.2. Calibration using a Helmholtz-type calibration coil.

Table B.4.0.3.3 Calibration frequencies and amplitudes

	Frequencies	Amplitudes
Band I	60, 100, 500, 1000 Hz	200, 2000 nT
Band II	15, 30, 60, 120 kHz	25, 250 nT

Recorded values for these calibrations shall not deviate more than $\pm 5\%$ from the nominal value. Due to the nature of the specified filters the deviation at 1 kHz shall be calculated from 180 nT and 1800 nT and at 120 kHz from 24 nT and 240 nT.

The calibration shall be performed for each of the three individual coils separately exposed and for one situation where approximately the same flux density passes through all three coils.

B.4.1 Alternating electric fields

B.4.1.0 Test laboratory requirements

Background electric field strengths in the test laboratory, including disturbances transmitted by power lines and internally generated noise in the measuring system, shall together not exceed 2.0 V/m in band I and 0.20 V/m in band II.

The mains voltage to the All-in-one PC under test shall be within $\pm 3\%$ of its nominal value.

B.4.1.1 Preparation of the All-in-one PC for testing

All necessary preparations described in B.0 and B.4.0 shall be done.

An external optical filter may not be used in order to comply with the mandatory requirement.

B.4.1.2 Equipment

Alternating electric field meter

B.4.1.3 Test Method

The true r.m.s.-value of the amplitude of the electric field strength, at the surface of the measuring probe, is measured in front of the test object in band I and in four azimuths in band II at 0° , 90° , 180° , 270° . Measurements are taken at both 0.3 m and 0.5 m from the surface of the product (see mandates). The frequency ranges are selected by means of filters in the measuring equipment.

Screens smaller or equal to 26"

The All-in-one PC shall be positioned such that the tangential plane, to the centre-centre point of the screen surface, is at a right angle to the horizontal plane. The distance between the centre-centre points of the screen surface and the back of the All-in-one PC, including an eventual part of a stand holder, along the normal to this tangential plane is called L, see Figure B.4.1.3.1.

The origin of the cylindrical co-ordinate system is chosen to be situated at a distance $L/2$ behind the screen surface on the normal to the tangential plane through the centre-centre point. The z-axis is chosen to be at a right angle to the horizontal plane. The angular reference direction is along the above mentioned normal in the direction pointing outwards from the screen. An angle (ϑ) is positive in the counter-clockwise direction. The measurement instrument is moving in a counter-clockwise direction around the test sample (as illustrated in the figure B.4.1.3.1).

The test co-ordinates are taken in four directions around the EUT at 0° , 90° , 180° , 270° . Measurements are taken at both 0.3 m and 0.5 m from the surface of the product (see mandates). Measurements at 90° , 180° , 270° shall maintain a minimum clearance of 0.5m from the AIO PC outer surface.

Distances are given in metres and angles in degrees. The co-ordinates are given for the centre of the measuring probe. The surface of the probe shall be perpendicular, within $\pm 5^\circ$, to the radial axis.

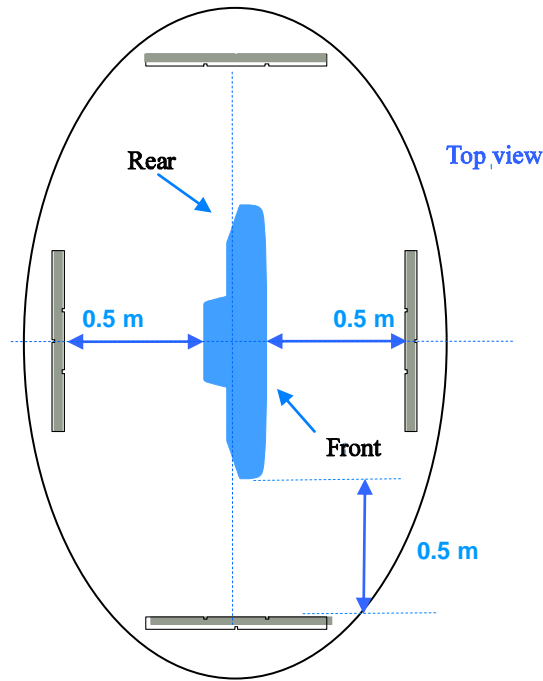

Figure B.4.1.3.1. Measurement geometry for band I and band II.

Screens larger than 26"

For screens larger than 26" measurements shall be taken in four directions around the product at 0°, 90°, 180°, 270°. All measurements shall be taken at only 0.5 m from the surface of the product.

For products that have a width or height ≥ 1 m additional measuring positions for front, rear and sides are required. The width and height of the screen does not include the frame but only the viewable screen area. The amount of positions depends on the size of the screen and is given in horizontal and vertical direction by the width and height in metres of the screen divided by 0.5 rounded to the closest integer. The positions shall be equally divided over the screen surface. See figure B.4.1.3.2.

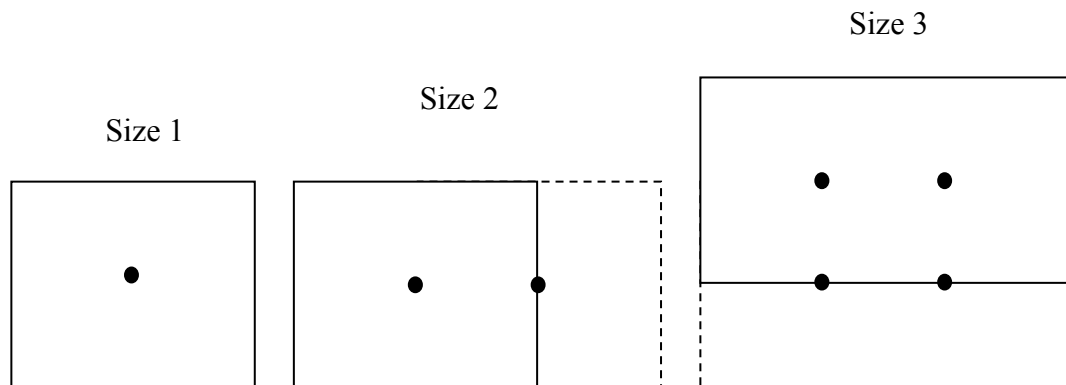

Figure B.4.1.3.2. Measurement point on different screen sizes. The dotted lines indicate a screen increase from size 1 by 0.5 m in width and then 0.5 m in height.

The All-in-one PC under test and the measuring probe shall be positioned at least 1 m from all significant metallic structures and objects apart from the test object.

Additional units and connecting cables necessary for the operation of the All-in-one PC, which are not part of the test, shall be placed so far away from the measuring setup that the fields they emit do not influence the measurement. Shielding may be added to these units and cables, as long as the 1 m clearance is maintained.

The measuring probe shall be connected to ground. Any eventual cables running between the measuring probe and the measuring instrument shall be positioned in such a way that they do not influence the measured value.

The power cable of the test object shall be connected to the phase and the neutral conductors of the mains power supply. If the mains power supply plug permits an interchange of the live and neutral conductors, measurements shall be taken with the connection that gives the highest reading in band I.

B.4.1.4 Test evaluation

Results shall be presented as r.m.s. values of the alternating electric field expressed in volt per meter (V/m). For band I, results shall be presented as the measured values at 0.3 m and 0.5 m for normal and stand-by operations if they differ. For band II, the measured values in front of the All-in-one PC and the maximum value at rotation shall be presented for normal and stand-by operations if they differ.

If the measured values are less than 10.0 V/m in band I or less than 1.0 V/m in band II the result shall be reported as “< 10.0 V/m” or “<1.0 V/m”, respectively.

If measuring more than one position on the front, rear or sides of the screen the worst-case shall be given in the report.

B.4.1.5 Overall uncertainty

The test shall be performed in such a way that the total extended uncertainty in the test result will be less than $\pm (10 \% \text{ of the reading} + 1.5 \text{ V/m})$ for band I and $\pm (10 \% \text{ of the reading} + 0.1 \text{ V/m})$ for band II.

B.4.2 Alternating magnetic fields

B.4.2.0 Test laboratory requirements

Background magnetic fields in the test laboratory, including disturbances transmitted along the power line and internally generated noise in the measuring system, shall together not exceed 40 nT in band I and 5 nT in band II.

B.4.2.1 Preparation of the All-in-one PC for testing

All necessary preparations described in B.0 and B.4.0 shall be done.

B.4.2.2 Equipment

Alternating magnetic field meter in band I and band II

B.4.2.3 Method

Screens smaller or equal to 26"

The true r.m.s. value of the amplitude of the magnetic flux density vector is measured at 12 points on a cylindrical surface around the test object in the two frequency ranges, band I and band II. The frequency ranges are selected by specified filters in the alternating magnetic field meter.

The measuring geometry is illustrated in Figure B.4.2.3.1. The measurement points are mathematically defined in the following way.

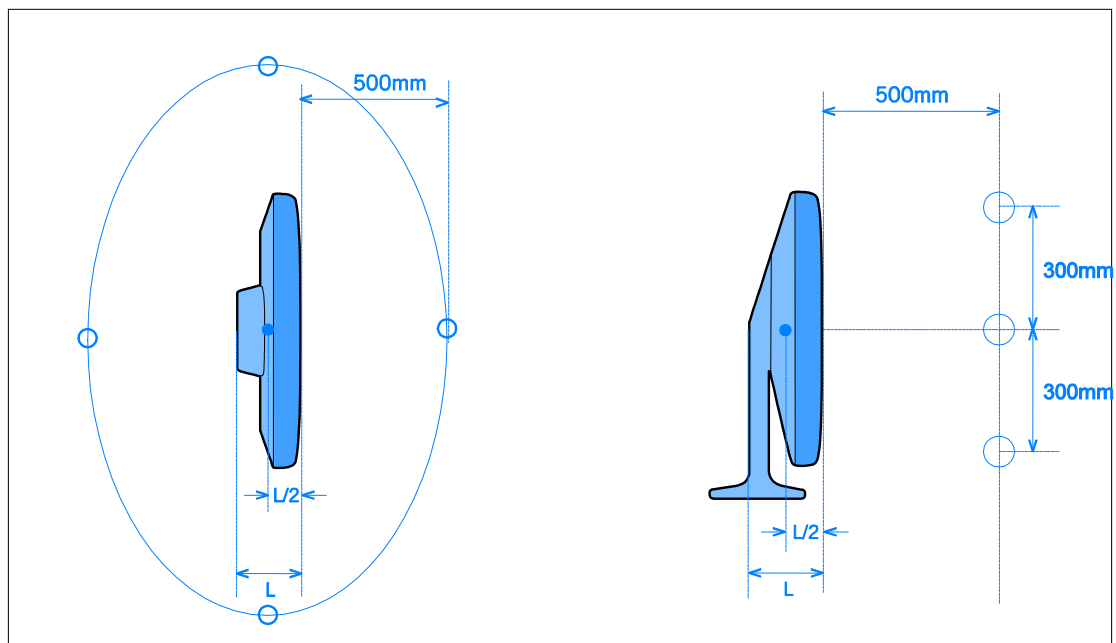

Figure B.4.2.3.1. Measurement geometry for the test object.

The All-in-one PC shall be positioned such that the tangential plane, to the centre-centre point of the screen surface, is at a right angle to the horizontal plane. The distance between the centre-centre points of the screen surface and the back of the All-in-one PC, including an eventual part of a stand holder, along the normal to this tangential plane is called L.

The origin of the cylindrical co-ordinate system is chosen to be situated at a distance $L/2$ behind the screen surface on the normal to the tangential plane through the centre-centre point. The z-axis is chosen to be at a right angle to the horizontal plane.

The angular reference direction is along the above-mentioned normal in the direction pointing outwards from the screen. An angle (°) is positive in the counter-clockwise direction. The measurement instrument is moving in a counter-clockwise direction around the test sample (as illustrated in the figure B.4.2.3.1).

The test co-ordinates are taken in four directions around the EUT at 0°, 90°, 180°, 270°. Measurements are taken at both 0.3 m and 0.5 m from the surface of the product (see mandates). Measurements at 90°, 180°, 270° shall maintain a minimum clearance of 0.5m from the AIO PC outer surface.

Screens larger than 26"

For screens larger than 26" measurements shall be taken in four directions around the product at 0°, 90°, 180°, 270°. All measurements shall be taken at only 0.5 m from the surface of the product.

For products that have a width or height ≥ 1 m additional measuring positions for front, back and sides are required. The width and height of the screen does not include the frame but only the viewable screen area. The amount of positions depends on the size of the screen and is given in horizontal and vertical direction by the width and height in cm of the screen divided by 0.5 rounded to the closest integer. The positions shall be equally divided over the screen surface see figure B.4.1.3.2.

The measuring coils shall be stationary during the measurements.

For All-in-one PC luminance settings – see General test conditions for emissions.

The power cable of the test object shall be connected to the phase and the neutral conductors of the mains power supply. The All-in-one PC does not need to be measured with the phase and neutral interchanged in this case, as the magnetic fields are not influenced by such a change.

B.4.2.4 Test evaluation

Results shall be presented as r.m.s. values of the magnetic flux density expressed in nanotesla (nT) for the two frequency bands. The values in front of the All-in-one PC and the maximum value and its position shall be given both for normal and for standby operation if they differ. If measured values are less than 200 nT in band I or less than 10.0 nT in band II the result shall be reported as "< 200 nT" and "< 10.0 nT" respectively.

B.4.2.5 Overall uncertainty

The test shall be performed in such a way that the total extended uncertainty in the test result will be less than $\pm (10 \% \text{ of the reading} + 30 \text{ nT})$ for band I and $\pm (10 \% \text{ of the reading} + 1.5 \text{ nT})$ for band II.

Note

The uncertainties given are worst case limits. In many cases it will be possible to obtain better accuracy, especially in band II.

B.4.3 Acoustic noise

The acoustic noise test shall only be carried out if the All-in-one PC has any internal moving mechanical parts

B.4.3.1 Method

Prior to testing, the PC shall have been switched on for 15 minutes.

Switch on the PC and begin recording elapsed time, starting either when the PC is initially switched on, or immediately after completing any log in activity necessary to fully boot the system. Once logged in with the operating system fully loaded and ready, close any open windows so that the standard operational desktop screen or equivalent ready screen is displayed.

Exactly 15 minutes after the initial boot or log in, start to accumulate test noise levels.

The noise measurements shall follow ISO 7779:2010 and shall be declared according to ISO 9296:1988. (However the principle for how the measurement uncertainty is handled shall be the same as for all the other criteria in this TCO Certification. This means that no uncertainty shall be added to the result presented in the report.)

In addition to reporting the measured *A-weighted sound power level* (L_{WA}) in Bels (B) the single measurement values of the 9 measurement positions and the mean value of these *A-weighted sound pressure level* (L_{pA}) in Decibels (dB) have to be included in the test report.

B.4.3.2 Overall uncertainty

The test shall be performed in such a way that the total extended uncertainty in the test result will be less than $\pm 2.5\text{dB}$.

Note

The uncertainties given are worst case limits. In many cases it will be possible to obtain better accuracy.

B.6 Environmental requirements

B.6.0 General Clarification

B.6.0.1 Signatures

The templates in the ecological declaration shall be sent either with original signatures or as copies of original documents with original signatures. “Copies” are for example telefaxes or pdf-files of scanned signed documents. TCO Development and/or the responsible laboratory may later request the original signed document.

However, copies will not be accepted where the signature has been scanned and pasted into the document.

TCO Development accepts digital signature as an alternative to traditional signature on test reports and declarations submitted as pdf files. To approve a digital signature it is necessary to also submit a digital key to the verifier to facilitate identification.

B.6.1 Product description

The A.6.1 template shall be completed with the requested information about the FPD. This includes the display, panel and when applicable the external power supply.

The type key that includes an Asterisk (*) for unidentified characters, if any, in the model name and panel identification name shall be submitted to the verifier. Only two * may be used in the model type key and each * must include two or more options. For the most up-to-date information about type keys, see the appropriate product Application Process at www.tcodevelopment.com

B.6.2 Organisation

B.6.2.1 Environmental management system certification

The certificate shall be issued by a certification body that is accredited by an accreditation body covered by the International Accreditation Forum, www.iaf.nu, Multilateral Arrangement on Environmental Management Systems.

For applicants submitting several applications, it is enough to attach an ISO 14001 certificate or EMAS registration with the first application.

The certificate or an appendix to the certificate shall show the scope of the certification.

B.6.3 Climate

B.6.3.1 Energy consumption – All-in-one PC

TCO Development require testing by a test laboratory approved by TCO Development. Testing shall be done according to the most recently published version of the Energy Star standard for computers and concerns only the Energy consumption requirements. The product does not have to be certified according to Energy Star.

The “Power supply efficiency requirement”

If the product has an Energy Star certificate, the TCO Development accepted test laboratory can base the test report on this certificate to show compliance with the Energy Star “Power supply efficiency requirement”. For products without Energy Star certificate the “Power supply efficiency requirement” may be tested by any laboratory accredited according to ISO 17025 and considered acting as a third party.

Test conditions, Supply Voltage

If the product has an Energy Star certificate TCO Development only require that one of the voltages is tested at a laboratory accepted by TCO Development. Other supply voltages may be verified through the existing Energy Star certificate. For products without Energy Star certificate all supply voltages must be tested at a laboratory accepted by TCO Development. The Supply Voltage shall be recorded in the test report.

The “Power management requirements”

The TCO Development accepted test laboratory can base the test report on a declaration from the manufacturer that the Energy Star “Power management requirements” are fulfilled.

B.6.3.1.1 Exemptions from the Energy Star standard

All exceptions and special requirements, test methods etc. specified by Energy Star are also accepted by TCO Development.

If testing concerns an update of an original certification (additional panel or adapter) that was issued to an older version of an Energy Star standard, then that older version may be used for testing.

Amounts of samples for testing

According to the TCO Certified criteria the manufacturer is responsible that the whole batch fulfil the demands. Furthermore, that the test is performed at a third party laboratory. Therefore TCO Development accept the test of only one sample even if the result is very close to the limit value.

B.6.3.2 Energy consumption – external power supply

TCO Development has decided that energy consumption of the external power supply shall follow the U.S. Environmental Protection Agency’s (EPA) demands for compliance with The International Efficiency Protocol requirement for level V, equivalent to the Energy Star version 2.0 for external adapters, also covering battery chargers.

The international efficiency mark consists of a Roman numeral (I – VI) that corresponds to specific minimum Active and No-Load efficiency levels (as well as a power factor requirement for level V) and is printed/applied by the manufacturer on the external power supply marking label.

A TCO Development laboratory will require to see a copy of the external power supply marking label there The International Efficiency Protocol requirement for level V symbol is visible as proof of compliance.

B.6.4 Environmentally hazardous substances

B.6.4.1 Cadmium (Cd), mercury (Hg), lead (Pb) and hexavalent chromium (CrVI)

Exemptions are according to EU Directive 2011/65/EU (RoHS) and the documents supporting the directive.

The maximum concentration values tolerated by weight in homogeneous materials for cadmium, mercury, lead and hexavalent chromium are according to EU Directive 2011/65/EU (RoHS) and the documents supporting the directive.

Limit value for mercury in lamps is maximum 3,5 mg Hg/lamp.

Note that 3,5 mg Hg/lamp is the maximum level allowed per lamp and not an average level calculated on a batch of lamps. This concerns lamps < 500 mm in length. For lamps between 500 mm and 1500 mm in length 5 mg Hg is allowed and for lamps over 1500 mm in length 13 mg Hg is allowed.

The limit value for batteries are according to the is 0,0005 % for mercury and 0,002 % for cadmium per listed part, according to EU Directive 2006/66/EC.

TCO Development supports the use of recycled plastic. To avoid making it more difficult to use recycled plastic, exceptions to this requirement can be accepted. If recycled plastic is used in the product please contact TCO Development for further instructions.

B.6.4.2 Halogenated substances

Mandate 1. The requirement applies to plastic parts in all assemblies and sub-assemblies. LCD panels are included in the requirement.

Exempted are printed wiring board laminates, electronic components and all kinds of cable insulation.

Mandate 2. The requirement applies to the whole of the FPD product, including components, parts and raw materials in all assemblies and sub-assemblies e.g. batteries, paint, surface treatment, plastics and electronic components. Printed Wiring Boards are also included in the requirement.

HBCDD has been identified as a Substance of Very High Concern in accordance with EU REACH criteria. The main application of HBCDD in EEE is as a flame retardant in HIPS plastic being used for closures and structural parts of different types of EEE. TCO Development considers that the use of HBCDD in EEE is not deemed essential as technically suitable alternative substances and materials are available and already used extensively today.

Maximum concentration values tolerated for a restricted substance (including decaBDE) is 0.1 % by weight in homogeneous materials.

TCO Development supports the use of recycled plastic. To avoid making it more difficult to use recycled plastic, exceptions to this requirement can be accepted. If recycled plastic is used in the product please contact TCO Development for further instructions.

B.6.4.3 Non-halogenated substances

Classification, Labelling and Packaging of Substances and Mixtures, known as the CLP Regulation, EC 1272/2008 came into force January 2009. The new regulation will eventually replace the Dangerous Substances Directive 67/548/EEC and Dangerous Preparations Directive 1999/45/EC. The transitional dates from which substance classification & labelling must be consistent with the new rules is 1 December 2010 (2012 if the substance is already on the shelves) and 1 June 2015 (2017) for mixtures (preparations).

Maximum concentration values tolerated for a restricted substance is 0.1 % by weight in homogeneous materials.

TCO Development supports the use of recycled plastic. To avoid making it more difficult to use recycled plastic, exceptions to this requirement can be accepted. If recycled plastic is used in the product please contact TCO Development for further instructions.

It takes time for the industry to phase hazardous substances out of productions. To give some preparation for that, the following list of substances are planned to be restricted in the next version of TCO Certified (*estimated publication Q1 2014*). The complete table with references and further information can be provided by TCO Development upon request.

Likely banned substances in the next version TCO Certified		
English name	CAS	Hazard statements
Antimony(III) oxide (Sb ₂ O ₃)	1309-64-4	H351
Tri-o-cresyl phosphate	78-30-8	H411, H370
Triethyl phosphate	78-40-0	H341, H350, H302, H319
Magnesium hydroxide	1309-42-8	H372, H315, H319, H335, H302, H332, H318,
	138265-88-0	H410, H400
Zinc borates (2ZnO.3B ₂ O ₃)	12767-90-7	H410, H400, H319
Triphenyl phosphate (TPP)	115-86-6	H411, H400, H410, H413, H319
Sodium toluene-4-sulphonate	657-84-1	H341, H351, H400, H301, H312, H317, H319, H332, H315, H335, H302, H318
Bis phenolA bis (biphenyl) phosphate (BDP)	181028-79-5	Technical grade contains TPP
(1-methylethylidene)di-4,1-phenylenetetraphenyl diphosphate	5945-33-5	Constituent of BDP, Technical grade contains TPP
Tri-cresyl phosphate	1330-78-5	H411, H400, H410, H413, H319, H317, H361, H373, H312, H302, H370
Cresyl diphenyl phosphate	26444-49-5	H410, H400, H302
Resorcinol bis (diphenyl diphosphate) (RDP)	57583-54-7	H411, H412

B.6.4.4 Plastics with chlorine and bromine as part of the polymer

TCO Development supports the use of recycled plastic. To avoid making it more difficult to use recycled plastic, exceptions to this requirement can be accepted. If recycled plastic is used in the product please contact TCO Development for further instructions.

B.6.4.5 Information regarding plastics, flame retarding agents and plasticizers

PWB laminates contained in LCD panels shall be listed if the conditions set out by the mandate are met.

B.6.5 Product lifetime

B.6.5.1 Warranty and spare parts

That spare parts shall be available for five years from “the time that production ceases” is only applicable to the production of the specific All-in-one PC, certified by the brand owner.

Regarding spare parts:

1. If a part of a product is broken (eg bezel, stand) the end user shall not need to replace the whole product, only the broken part. The broken part shall be possible to replace with an equivalent part (this part does not have to be identical to the broken part).
2. When the cost for replacing a broken part (e.g. panel) exceeds the cost of replacing the whole product, then that part need not be considered as a spare part under this mandate.

B.6.6 Preparation for Recycling

B.6.6.1 Material coding of plastics

If the amount of flame retardant exceeds 1 % by weight the coding shall be complemented in accordance with ISO 1043-4.

The requirements also apply to plastics in the LCD panel, however labelling of the light guide may instead consist of the application of a label in close proximity, for example PLASTIC LIGHT GUIDE:>plastic type(s)< or >PLASTIC LIGHT GUIDE:plastic type(s)<. Labelling of Plate diffuser (not thin plastic film diffuser) shall follow the same rules as for the light guide.

The requirement does not cover other thin plastic films in the panel due to difficulties in labelling these.

B.6.6.2 Variety of plastics

Clarification: A different additive marking will not make the plastic a different plastic type. For example ABS with FR40 and ABS with FR50 is considered *one* plastic type (two are still allowed).

B.6.6.3 Metallization of plastic housing and metal parts

The requirement applies to the outer plastic casing and the foot of the display. Housings for electronic components inside the outer casing are not included in the requirement.

When the virgin plastic already in its granulated form contains additives, consisting for example of metal oxides in the form of pigment or metal flakes, this is not considered to be metallization and is not included in the prohibitions defined in A.6.6.3.

Metallized plastic control buttons for the adjustment of screen contrast, brightness, colour, etc. are accepted.

Metal parts and metallized plastics parts are acceptable if they are Post Mould Inserts or Snap-Fastening type and can be easily removed using standard tools. In Mould Insert Moulding or glued metal parts are not accepted. Strong double-sided tape, difficult to separate is not accepted.

Post mould inserting is the process by which a metal insert is fixed into an already moulded plastic by means of a secondary process. Inserts may use heat fusion or deep threads to create a secure bond with the plastic.

Clarification: All exceptions on metallised parts described above must fulfil the RoHS Directive.

B.6.6.4 Preparation for recycling - Mercury lamps

The panel technology shall be reported as LCD (TFT, NT, DSTN, etc.), plasma, or other (specified).

A disassembly description for every specified LCD panel shall be submitted.

Not applicable to LED technology.

B.6.6.5 Take back system

Tick the box of the option chosen.

If the applicant chooses **option 1** (*Product only sold on markets with WEEE legislation or similar*) and signs the declaration, the requirement is fulfilled.

If **option 2 or 3** (*World-wide product take back or One additional market lacking WEEE legislation where product take back is offered*) is chosen, the declaration must be signed and the applicant must provide a short description of how the take-back system on that market works. This can also be done by giving a reference (for example a link to a website) to the representative, associated company or affiliate taking care of the take-back system on that market.

In case of option 3 the applicant must also provide the name of the market (country) where a take back system is provided.

TCO Development has no requirement on the take-back system being free of charge.

It is important to point out that any recycling and waste export control legislation in countries where the applicant company operates must always be met.

B.6.7 Product packaging

B.6.7.1 Hazardous substances in product packaging

Limit values are according to Directive 94/62/EC on packaging and packaging waste.

B.7 Corporate Social Responsibility

B.7.1.1 General Clarifications

TCO Development is from this version of the criteria taking the next step in relation to Corporate Social Responsibility (CSR) by introducing an extended mandate regarding supply chain responsibility, since the way in which products are produced is gaining importance for consumers as well as professional buyers. Within the ICT industry supply chain responsibility is increasingly seen as a hygiene determinant.

We aim to be a sustainability label that assures good products in three relevant areas – environmental, social and ergonomics. We want the label to be proof for compliance with public procurement ethical criteria as well as with private sector CSR policies.

The Social performance criteria are based on the eight ILO core conventions and local legislation. This stipulates minimum standards as for the situation in the production facilities. ILO (International Labour Organization) is a United Nations specialized agency with the aim to promote social justice and humane working conditions. The organization consists of representatives of national states, corporations and labour unions.

It is also important the Brand owner has an appointed senior management representative who, irrespective of other responsibilities, ensures that the requirements of this mandate are met. The contact details of this person shall be submitted and shall be available for dialogue in English with TCO Development throughout the certification period. This aims to create an open and transparent dialogue between TCO Development and the brand owner company.

B.7.1.1.1 Electronic Industry Citizenship Coalition (EICC)

The Electronic Industry Citizenship Coalition (EICC) is a group of companies working together to create a comprehensive set of tools and methods that support credible implementation of the Electronic Industry Code of Conduct throughout the Electronics and Information and Communications Technology (ICT) supply chain.

The Electronic Industry Code of Conduct is a code of best practices adopted and implemented by some of the world's major electronics brands and their suppliers. The goal is to improve conditions in the electronics supply chain. Development of the Code was a multi-stakeholder effort, influenced by internationally-recognized standards. By consolidating and standardizing compliance, audit and reporting efforts, suppliers can focus on achieving the high standards of performance set forth by the Code. This approach is also conducive to fostering a culture of social responsibility throughout the global electronics supply chain. EICC sets forth performance, compliance, auditing and reporting guidelines across five areas of social responsibility:

- Labour
- Health and Safety
- Environmental
- Management System
- Ethics

As documented proof we require:

1. An EICC membership document
2. An annual list (that is not older than 12 months) of all third party audits of compliance with the EICC code of conduct, conducted at the first tier production facilities of TCO certified products.
3. One full report of a third party audit (that is not older than 12 months) conducted at a first tier production facility of TCO certified products.

If the brand owner cannot present a full report that has been conducted during the last 12 months, then a final option is to buy one audit (for a subsidized fee) from a third party appointed by TCO Development.

More information:

<http://www.eicc.info/>

B.7.1.1.2 SA8000

SA8000 is a global social accountability standard for decent working conditions, developed and overseen by Social Accountability International (SAI). SAI contracts with a global accreditation agency, Social Accountability Accreditation Services (SAAS) that licences and oversees auditing organisations to award certification to employers that comply with SA8000.

SA8000 is based on the UN Universal Declaration of Human Rights, Convention on the Rights of the Child and various International Labour Organization (ILO) conventions. SA8000 covers the following areas of accountability:

- **Child labour:** No workers under the age of 15; minimum lowered to 14 for countries operating under the ILO Convention 138 developing-country exception; remediation of any child found to be working.
- **Forced labour:** No forced labour, including prison or debt bondage labour; no lodging of deposits or identity papers by employers or outside recruiters.
- **Workplace safety and health:** Provide a safe and healthy work environment; take steps to prevent injuries; regular health and safety worker training; system to detect threats to health and safety; access to bathrooms and potable water.
- **Freedom of Association and Right to Collective Bargaining:** Respect the right to form and join trade unions and bargain collectively.
- **Discrimination:** No discrimination based on race, caste, origin, religion, disability, gender, sexual orientation, union or political affiliation, or age; no sexual harassment.
- **Discipline:** No corporal punishment, mental or physical coercion or verbal abuse.
- **Working hours:** Comply with the applicable law but, in any event, no more than 48 hours per week with at least one day off for every seven day period; voluntary overtime paid at a premium rate and not to exceed 12 hours per week on a regular basis; overtime may be mandatory if part of a collective bargaining agreement.
- **Remuneration:** Wages paid for a standard work week must meet the legal and industry standards and be sufficient to meet the basic need of workers and their families; no disciplinary deductions.
- **Management system for Human Resources:** Facilities seeking to gain and maintain certification must go beyond simple compliance to integrate the standard into their management systems and practices.

As documented proof we require:

1. A valid SA8000 certificate documenting compliance with the standard. The Brand owner shall be SA8000 certified or carrying out production at first tier production facilities that are SA8000 certified.
2. An annual list (that is not older than 12 months) of all third party audits conducted at the first tier production facilities of TCO certified products.

3. One full report of a third party audit (that is not older than 12 months) conducted at a first tier production facility of TCO certified products.

If the brand owner cannot present a full report that has been conducted during the last 12 months, then a final option is to buy one audit (for a subsidized fee) from a third party appointed by TCO Development.

More information:

<http://www.sa-intl.org/>

B.7.1.1.3 Self-documentation

Verification is made through completing a questionnaire provided by TCO Development. There are 10 questions concerning the brand owner's company work with implementing the minimum requirements on working conditions in the production of TCO Certified products. The answers shall be signed by the senior management representative and as far as possible supported by documentation.

To be accepted as fulfilling the TCO Development social criteria the brand owner company shall provide proof of having implemented structured CSR work with their first tier production facilities and make reasonable efforts with respects to suppliers. Our ambition is to ensure that the risk of the production not being in compliance with the requirements is minimized.

The questions cover such areas as the implementation and content of a code of conduct or similar demands on first tier production facilities, auditing and follow up of social criteria, trade union rights and representation, activities to avoid discrimination and the dialogue with suppliers.

As documented proof we require:

1. A completed and by CSR verifier approved TCO Development questionnaire. The Questionnaire and Guidelines for the assessment are public and can be downloaded at: www.tcodevelopment.com
2. An annual list (that is not older than 12 months) of all third party audits conducted at the first tier production facilities of TCO certified products.
3. One full report of a third party audit (that is not older than 12 months) conducted at a first tier production facility of TCO certified products.

If the brand owner cannot present a full report that has been conducted during the last 12 months, then a final option is to buy one audit (for a subsidized fee) from a third party appointed by TCO Development.

B.7.1.1.4 Brand owners not yet having the required CSR process in place (Grace Period).

Brand owners utilizing first tier production facilities that do not yet comply with the criteria are given a 12 month grace period to reach a level of engagement that complies.

In this case a signed guarantee by the brand owner stating an estimated date of compliance is required to be submitted with the application. It is then the verifier's responsibility to check that the brand owner has obtained a level of compliance within the grace period. If the necessary documentation is not received within the 12 month grace period then TCO Development shall be contacted by the verifier so a course of action can be decided.

B.7.1.1.5 On-site inspection instigated by the Brand owner (Social revision)

The third party auditor used by the applicant to carry out factory inspections and deliver the report, shall have documented experience of carrying out social auditing. The auditor should have undergone the SA8000 Advanced Auditor Training or an equivalent training course

B.7.1.1.6 On-site inspection instigated by TCO Development (Social revision)

TCO Development reserves the right to require full audit reports and conduct or commission on-site inspections at first tier production facilities to verify that the Brand owner is fulfilling the obligations according to this mandate. The planning of social audits will be done in cooperation with the Senior Management Representative appointed by the brand owner. Audits will be implemented by TCO Developments partner organisation for the actual geographic region. On factory level, inspections should be able to be unannounced visits. Social audits initiated by TCO Development will be realized on a judgement sample basis, in each case decided by and financed by TCO Development.